

4DLCD-32QA

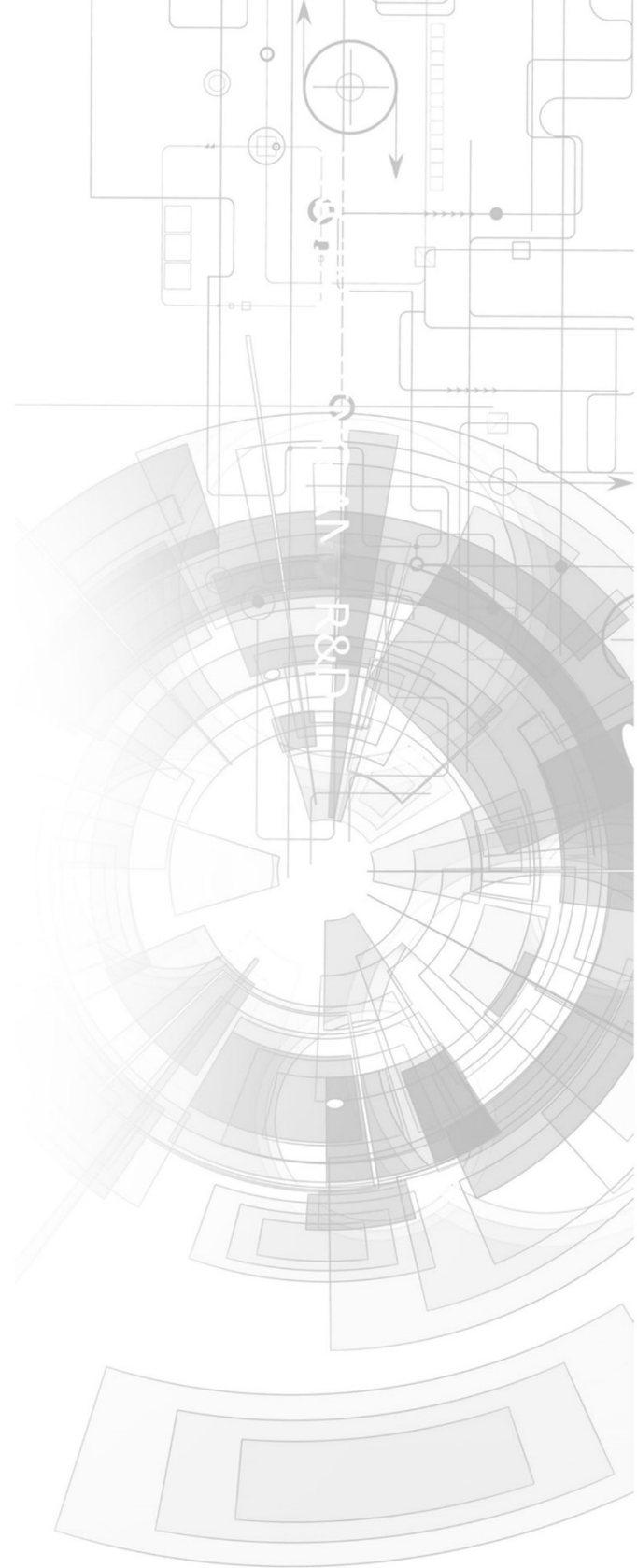

Datasheet

Revision 1.2

Copyright © 2023 4D Systems

Content may change at any time. Please refer to the resource centre for latest documentation.

Contents

1. Specifications	3
1.1. Mechanical Specifications	4
1.2. Pin Descriptions	5
2. Electrical Specifications	7
2.1. Absolute Maximum Ratings	7
2.2. DC Characteristics	7
2.3. LED Backlight Maximum Ratings	8
3. Optical Characteristics	9
4. Touch Characteristics	10
5. Initialisation Codes	11
5.1. Command Definitions	11
5.2. Init Code	12
6. Quality Testing	13
6.1. Reliability Test	13
6.2. Color Performance	13
7. Precautions for Using LCD Modules	14
7.1. Handling Precautions	14
7.2. Storage Precautions	16
8. Using LCD Modules	17
8.1. Installing LCD Modules	17
8.2. Precautions for Operation	18
8.3. Safety	18
8.4. Return LCM under Warranty	19
9. Revision History	20

1. Specifications

 General Specifications		
S.No.	Items	Specifications
1	Screen size (inch)	3.2" Diagonal
2	LCD Type	TFT, Normally White, TRANSMISSIVE
3	Colors	65K Colors
4	Display Resolution	240 x RGB x 320
5	Module Outline (mm)	55.04 x 77.7 x 2.4 (W x H x T)
6	Active Area (mm)	48.60 x 64.80 (W x H)
7	Touch Panel Dimension	76.2 x 53.4 x 1.2
8	Viewing Direction	12:00 O' Clock
9	Pixel Arrangement	RGB Vertical Stripe
10	Interface	8080, 8/16 bit CPU Interface
11	Assembly Type	Connector type FPC
12	Driver IC	ILI9341
13	Backlight	6 x White LED
14	Pixel Arrangement	RGB Vertical Stripe

1.1. Mechanical Specifications

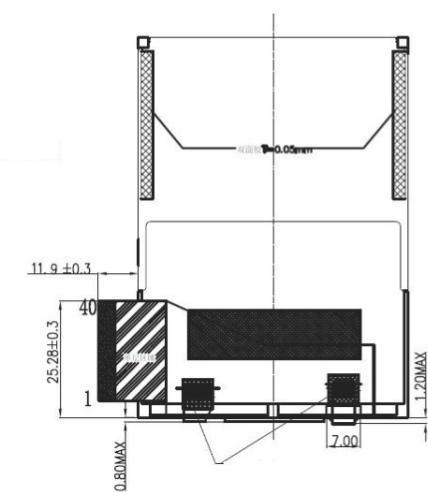
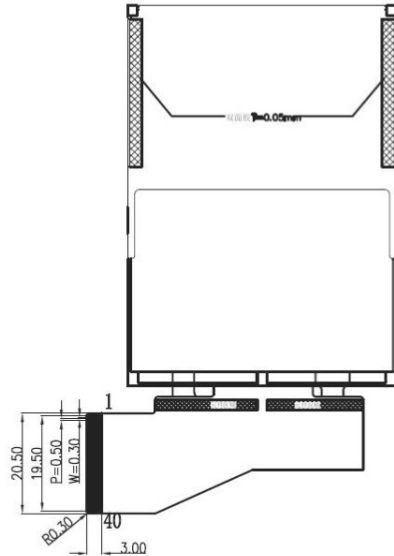
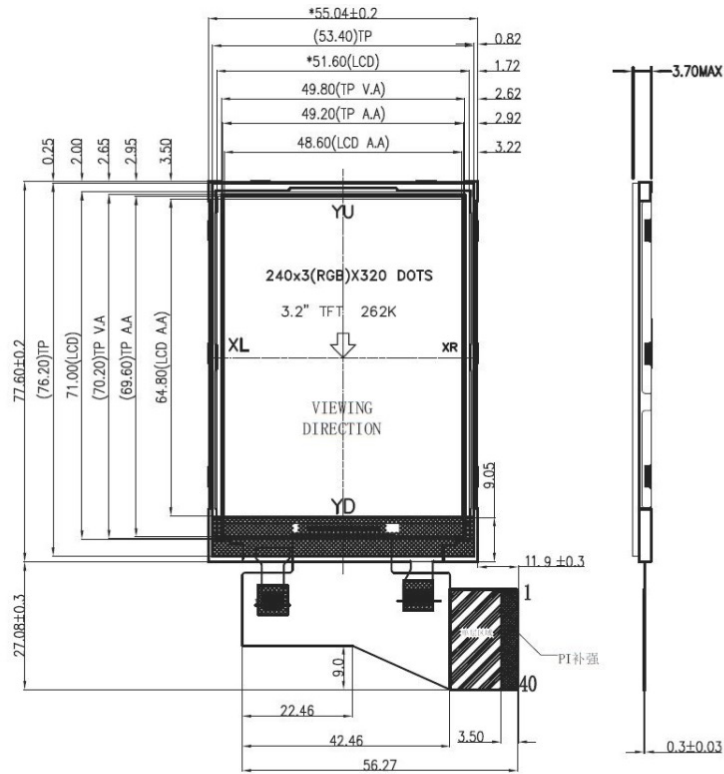

NO.	Pin name
1	GND
2	GND
3	IM0(8/16)
4	FMARK
5	YD
6	XL
7	RESET
8	RS
9	CS
10	RD
11	WR
12	VCC=3.3V
13	NC
14	GND
15	DB15
16	DB14
17	DB13
18	DB12
19	DB11
20	DB10
21	DB9
22	DB8
23	DB7
24	DB6
25	DB0
26	DB1
27	DB2
28	DB3
29	DB4
30	DB5
31	YU
32	XR
33	LEDA
34	LEDK1
35	LEDK2
36	LEDK3
37	LEDK4
38	LEDK5
39	LEDK6
40	GND

NOTES:

- 1.DISPLAY TYPE: 3.2" TFT 262K, Transmissive
- 2.OPERATING TEMP: -20°C~70°C
- 3.STORAGE TEMP: -30°C~80°C
- 4.LCD DRIVER: ILI9341
- 5.VIEWING DIRECTION: 12 O'CLOCK
- 8.THE TOLERANCE UNLESS CLASSIFIED ±0.2mm

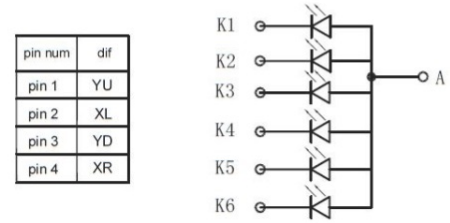

LED CIRCUIT DIAGRAM

1.2. Pin Descriptions

Pin	Symbol	I/O	Function
1	GND	Power	Ground
2	GND	Power	Ground
3	IMO(8/16)	Control	Interface Mode 0 : for 16bit Mode 1 : for 8bit Mode
4	FMARK	Control	Output a frame head pulse signal
5	Y- (YD)	INPUT	Touch Panel Y
6	X+ (XL)	INPUT	Touch Panel X
7	RESET	INPUT	A Reset Signal
8	RS	INPUT	A Register select signal
9	CS	INPUT	A Chip select signal
10	RD	INPUT	Read signal
11	WR	INPUT	Write signal
12	VCC	Power	3.3V: Analog Power Supply
13	NC	-	Not Connected
14	GND	Power	Ground
15~22	DB15~ DB08	I/O	Parallel interface data bus
23	DB7	I/O	Parallel interface data bus
24	DB6	I/O	Parallel interface data bus
25	DB0	I/O	Parallel interface data bus
26	DB1	I/O	Parallel interface data bus
27	DB2	I/O	Parallel interface data bus
28	DB3	I/O	Parallel interface data bus
29	DB4	I/O	Parallel interface data bus
30	DB5	I/O	Parallel interface data bus
31	Y+ (YU)	INPUT	Touch Panel Y
32	X- (XR)	INPUT	Touch Panel X
33	LEDA		LED Anode
34	LEDK1		LED cathode

Pin	Symbol	I/O	Function
35	LEDK2		LED cathode
36	LEDK3		LED cathode
37	LEDK4		LED cathode
38	LEDK5		LED cathode
39	LEDK6		LED cathode
40	GND		Power Ground

2. Electrical Specifications

2.1. Absolute Maximum Ratings

Absolute Maximum Ratings						
Items	Symbol	Condition	Min.	Max.	Unit	
Power supply Voltage	V_{CI}	$T_a = +25^{\circ}\text{C}$	-0.3	+4.6	V	
Operating Temperature	T_{OP}	-	-20	+70	$^{\circ}\text{C}$	
Storage Temperature	T_{ST}	-	-30	+80	$^{\circ}\text{C}$	
Storage Humidity	H_D	-	20	90	%RH	

Caution

Any stresses exceeding the absolute Maximum Ratings may cause substantial damage to the device.

2.2. DC Characteristics

DC Characteristics						
Items	Symbol	Conditions	Min.	Typ.	Max.	Unit
Power supply voltage	V_{CI}	$T_a = +25^{\circ}\text{C}$	2.5	-	3.3	V
Input High Voltage	V_{IH}		$0.8V_{CI}$	-	V_{CI}	V
Input Low Voltage	V_{IL}		GND	-	$0.2V_{CI}$	V
Output High Voltage	V_{OH}		$0.8V_{CI}$	-	-	V
Output Low Voltage	V_{OL}		-	-	$0.2V_{CI}$	V
Power consumption	P_{LCD}	Excluding Backlight	-	30	-	mW

2.3. LED Backlight Maximum Ratings

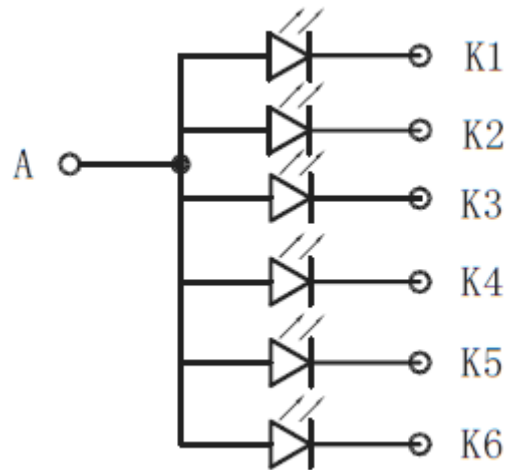

LED Backlight Maximum Ratings

Items	Symbol	Conditions	Min.	Typ.	Max.	Unit	Comments
Forward Current	I_{LED}	$T_a = +25^{\circ}\text{C}$	18	20	25	mA	Single LED
Forward Voltage	V_F		3.2	3.3	3.6	V	Single LED
Power Dissipation	P_D		288	330	450	mW	Backlight unit

3. Optical Characteristics

The following items are measured under stable conditions. The optical characteristics should be measured in a dark room or equivalent state with the methods shown in Note (2).

Optical Characteristics @ Ta = 25 ± 2°C						
Item	Symbol	Condition	Min	Typ	Max	Unit
Brightness	L	White pattern	160	200	-	cd/m ²
Response Time	T _R + T _F	θ = 0° = 0	-	25	-	ms
Contrast Ratio	CR	At the Center point of A.A	300	350	-	
Color Chromaticity White	W _X	θ = 0° = 0	0.237	0.313	0.353	
Color Chromaticity White	W _Y		0.289	0.329	0.369	
Viewing Angle Horizontal		CR ≥ 10	-	110	-	Deg
Viewing Angle Vertical			-	120	-	Deg

Note

1. These parameters are measured by C light.
2. Definition of Viewing Angle

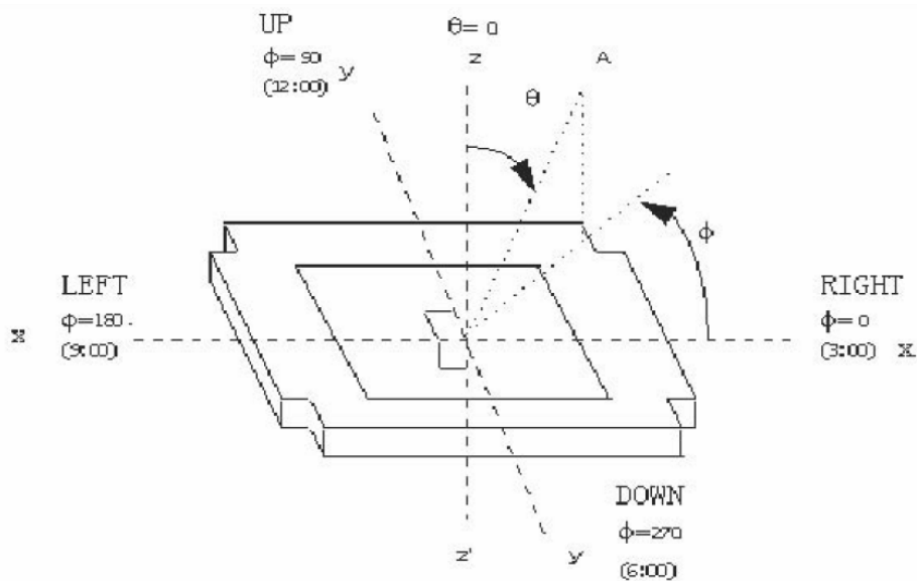

The Screens used are the highest rated '**Grade A**' Displays which allow for 0-4 defective pixels. A defective pixel could be solid Black (Dead), Red, Green or Blue. 4D Systems is not liable for a return/replacement for any Display that has 4 or fewer defective pixels.

4. Touch Characteristics

Touch Parameters					
Parameter	Conditions	Min	Typ	Max	Units
Operating Voltage		-	5	-	V
Linearity		±1.5			%
Terminal Resistance X	X film side	300	400	800	Ohm
Terminal Resistance Y	Y film side	300	600	800	Ohm
Operating Temperature		-10	-	60	°C
Storage Temperature		-20	-	70	°C
Transmittance		80	-	-	%
Life Time – Tapping Durability		1	-	-	Million
Life Time – Pen Durability	Stylus Pen or Finger Press	1	-	-	Million
Response Time				10	ms

- **ITO Film:** Single Layer/Clear Hard Coating
- **Tail Type:** FPC by Golden Plated
- **Connection:** FPC Connector
- **RoHS Compliant**

5. Initialisation Codes

5.1. Command Definitions

 Command Definitions	
READ_DISPLAY_PIXEL_FORMAT	0x0C
SLEEP_OUT	0x11
GAMMA_SET	0x26
DISPLAY_OFF	0x28
DISPLAY_ON	0x29
SET_COLUMN_ADDRESS	0x2A
SET_PAGE_ADDRESS	0x2B
WRITE_MEMORY	0x2C
READ_MEMORY	0x2E
MEMORY_ACCESS_CONTROL	0x36
WRITE_MEMORY_CONTINUE	0x3C
READ_MEMORY_CONTINUE	0x3E
PIXEL_FORMAT_SET	0x3A
FRAME_RATE_CONTROL	0xB1
DISPLAY_FUNCTION_CONTROL	0xB6
POWER_CONTROL_1	0xC0
POWER_CONTROL_2	0xC1
VCOM_CONTROL_1	0xC5
VCOM_CONTROL_2	0xC7
POWER_CONTROL_A	0xCB
POWER_CONTROL_B	0xCF
POSITIVE_GAMMA_CORRECTION	0xE0
NEGATIVE_GAMMA_CORRECTION	0xE1
DRIVER_TIMING_CONTROL_A	0xE8
DRIVER_TIMING_CONTROL_B	0xEA
POWER_ON_SEQUENCE_CONTROL	0xED
UNDOCUMENTED_0xEF	0xEF
ENABLE_3G	0xF2
INTERFACE_CONTROL	0xF6

5.2. Init Code

Format: (Command, Data1, Data2...DataN)

```
INTERFACE_CONTROL, 0x01, 0x01, 0x00,  
UNDOCUMENTED_0xEF, 0x03, 0x80, 0x02,  
POWER_CONTROL_B, 0x00, 0xF2, 0xA0,  
POWER_ON_SEQUENCE_CONTROL, 0x64, 0x03, 0x12, 0x81,  
POWER_CONTROL_A, 0x39, 0x2C, 0x00, 0x34, 0x02,  
DRIVER_TIMING_CONTROL_B, 0x00, 0x00,  
DRIVER_TIMING_CONTROL_A, 0x85, 0x10, 0x7A,  
POWER_CONTROL_1, 0x21,  
POWER_CONTROL_2, 0x11,  
VCOM_CONTROL_1, 0x3F, 0x3C,  
VCOM_CONTROL_2, 0xC6,  
PIXEL_FORMAT_SET, 0x55,  
MEMORY_ACCESS_CONTROL, 0x00,  
FRAME_RATE_CONTROL, 0x00, 0x1B,  
DISPLAY_FUNCTION_CONTROL, 0x0A, 0xA2,  
ENABLE_3G, 0x00,  
GAMMA_SET, 0x01,  
POSITIVE_GAMMA_CORRECTION, 0x0f, 0x24, 0x21, 0x0F, 0x13, 0x0A, 0x52, 0xC9, 0x3B, 0x05, 0x00,  
0x00, 0x00, 0x00, 0x00,  
NEGATIVE_GAMMA_CORRECTION, 0x00, 0x1B, 0x1E, 0x00, 0x0C, 0x04, 0x2F, 0x36, 0x44, 0x0a, 0x1F,  
0x0F, 0x3F, 0x3F, 0x0F,  
WRITE_MEMORY,  
SLEEP_OUT,  
DelayMS 120,  
DISPLAY_ON
```

6. Quality Testing

The LCD Module should be designed to meet a minimum MTTF value of 50,000 hours under normal operating conditions. T = 25 ± 2°C, Indoors, Not exposed to sunlight. Note, Backlight lifetime is not included.

Criterion:

- No defect of Operational Function at Room Temperature is allowable.
- The leakage current should be below double the initial value.

6.1. Reliability Test

No.	ITEM	CONDITION	Pass/Fail
1	High Temperature Operating	70°C, 240Hrs	Pass
2	Low Temperature Operating	-20°C, 240Hrs	Pass
3	High Temperature Non-Operating	80°C, 240Hrs	Pass
4	Low Temperature Non-Operating	-30°C, 240Hrs	Pass
5	High Temperature/Humidity Non-Operating	50°C, 90%RH, 240Hrs	Pass
6	Temperature Shock Non-Operating	-30°C, <- -> 80°C, 10 cycles 30min→5min→30min	Pass
7	Electrostatic Discharge	HBM: ±2KV	Pass

Note

1. Test after 24 hrs at room temperature.
2. The sampling above is individual for each reliability test.
3. The color fading of the polarization filter should not care.
4. The entire reliability testing chamber above is using D.I. water (Min value: 1.0MOhm-cm)
5. In case of a malfunction defect caused by the ESD Damage, If it could be recovered to a normal state after resetting, it would be considered a good part.

6.2. Color Performance

S. No.	ITEM	CONDITION
1	Luminance	> 50%
2	NTSC	> 70%
3	Contrast Ratio	> 50%

7. Precautions for Using LCD Modules

7.1. Handling Precautions

- The display panel is made of glass and a polarizer. The glass is fragile. It tends to be chipped during handling, especially on the edges. Please avoid dropping or jarring. Please be careful not subject it to a mechanical shock by dropping it on impact.
- If the display panel is damaged and the liquid crystal substance leaks out, be sure not to get any of it in your mouth. If the substance contacts your skin or clothes, wash it off using soap and water.
- Do not apply excessive force to the display surface or the adjoining areas since this may cause the color tone to vary. Do not touch the display with bare hands. This will stain the display area and degrade insulation between terminals (some cosmetics are determined by the polarizer).
- The polarizer covering the display surface of the LCD module is soft and easily scratched. Handle this polarizer carefully. Do not touch, push or rub the exposed polarizer with anything harder than an HB pencil lead (e.g., glass, tweezers, etc.). Do not put or attach anything to the display area to avoid leaving marks on it. Condensation on the surface and contact with terminals due to cold temperatures will damage, stain or contaminate the polarizer. After products are tested at low temperatures they must be warmed up in a container before coming into contact with room-temperature air.
- If the display surface becomes contaminated, breathe on the surface and gently wipe it with a soft dry cloth. If it is heavily contaminated, moisten the cloth with one of the following solvents
 - Isopropyl alcohol
 - Ethyl alcohol Do not scrub hard as it might damage the display surface.
- Solvents other than those mentioned above may damage the polarizer. Especially the following.
 - Water
 - Ketone
 - Aromatic solvents Wipe off saliva or water drops immediately, contact with water over a long period may cause deformation or color fading. Avoid contact with oil and fat.
- Take necessary precautions to minimize corrosion of the electrode. Corrosion of the electrodes is accelerated by water droplets, moisture condensation or current flow in a high-humidity environment.
- Install the LCD Module by using the mounting holes. When mounting the LCD module, make sure it is free of twisting, warping and distortion. In particular, do not forcibly pull or bend the I/O cable or the backlight cable.
- Do not attempt to disassemble or process the LCD module.
- NC terminal should be open. Do not connect anything to it.
- If the logic circuit power is off, do not apply input signals.

- Control Electro-Static Discharge. Since this module uses a CMOS LSI, the same careful attention should be paid to electrostatic discharge as for an ordinary CMOS IC. To prevent the destruction of the elements by static electricity, ensure that an optimum work environment is maintained.
 - Before removing the LCM from its packing case or incorporating it into a set, be sure that the module and your body have the same electric potential. Be sure to ground your body when handling the LCD modules.
 - To reduce the amount of static electricity generated, do not conduct assembly and other work under dry conditions. To reduce the generation of static electricity, please ensure that the air in the work environment is not too dry. Relative humidity of 50%-60% is recommended. As much as possible, make the electric potential of your work clothes and that of the workbench the ground potential.
 - The LCD module is coated with a film to protect the display surface. Be careful when peeling off this protective film since static electricity may be generated.
- Since the LCM has been assembled and adjusted with a high degree of precision, avoid applying excessive shocks to the module or making any alterations or modifications to it.
 - Do not alter, modify or change the shape of the tab on the metal frame.
 - Do not make extra holes on the printed circuit board, modify its shape or change the positions of the components to be attached.
 - Do not damage or modify the pattern writing on the printed circuit board.
 - Do not modify the zebra rubber strip (conductive rubber) or heat seal connector.
 - Do not drop, bend or twist the LCM.

7.2. Storage Precautions

When storing the LCD modules, the following precautions are necessary.

- Store them in a sealed polyethylene bag. If properly sealed, there is no need for the desiccant.
- Store them in a dark place. Do not expose to sunlight or fluorescent light, keep the temperature between 0°C and 35°C, and keep the relative humidity between 40%RH and 60%RH.
- The polarizer surface should not come in contact with any other objects. (We advise you to store them in an anti-static electricity container in which they were shipped. Some Liquid crystals solidify under low temperatures (below the storage temperature range) leading to defective orientation or the generation of air bubbles (black or white). Air bubbles may also be generated if the module is subjected to low temperatures.
- If the LCD modules have been operating for a long time showing the same display patterns, the display patterns may remain on the screen as ghost images and a slight contrast irregularity may also appear. A normal operating status can be regained by suspending use for some time. It should be noted that this phenomenon does not adversely affect performance reliability.
- To minimize the performance degradation of the LCD modules resulting from the destruction caused by static electricity etc., please avoid holding the following sections when handling the modules'
 - The exposed area of the printed circuit board
 - Terminal electrode sections

8. Using LCD Modules

8.1. Installing LCD Modules

The hole in the printed circuit board is used to fix LCM as shown in the picture below. Attend to the following items when installing the LCM.

1. Cover the surface with a transparent protective plate to protect the polarizer and LC cell.

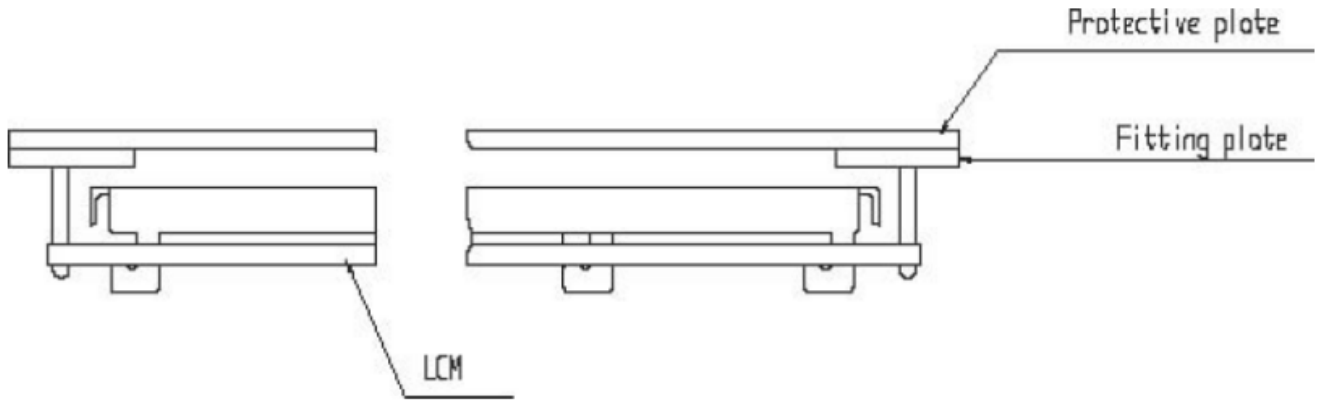

2. When assembling the LCM into other equipment, the spacer to the bit between the LCM and the fitting plate should have enough height to avoid causing stress to the module surface, refer to the individual specifications for measurements. The measurement tolerance should be $\pm 0.1\text{mm}$. Precaution for assembling the module with BTB connector:

Please note the position of the male and female connector position, don't assemble or assemble like the method that the following picture shows.

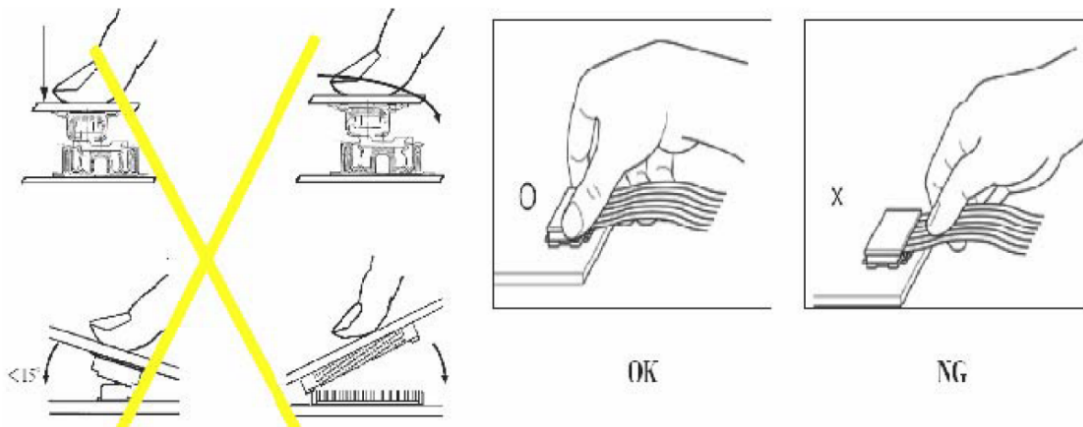

8.2. Precautions for Operation

1. The viewing angle varies with the change in liquid crystal driving voltage (VLCD). Adjust VLCD to show the best contrast.
2. It is an indispensable condition to drive LCDs within the specified voltage limit since a higher voltage than the limit causes a shorter LCD life. An electrochemical reaction due to direct current causes LCD's undesirable deterioration so the use of a direct current drive should be avoided.
3. Response time will be extremely delayed at a lower temperature than the operating temperature range and on the other hand at higher temperatures it shows dark color in them. However, those phenomena do not mean malfunction or out-of-order with LCDs, which will come back at the specified operating temperature.
4. If the display area is pushed hard during operation, the display will become abnormal. However, it will return to normal if it is turned off and then back on.
5. Slight dew depositing on terminals is a cause for electrochemical reaction resulting in terminal open circuit. Usage under the maximum operating temperature, 50%RH or less is required.
6. Input each signal after the positive/negative voltage becomes stable.
7. Please keep the temperature within the specified range for use and storage. Polarization degradation, bubble generation or polarizer peel-off may occur with high temperature and high humidity.

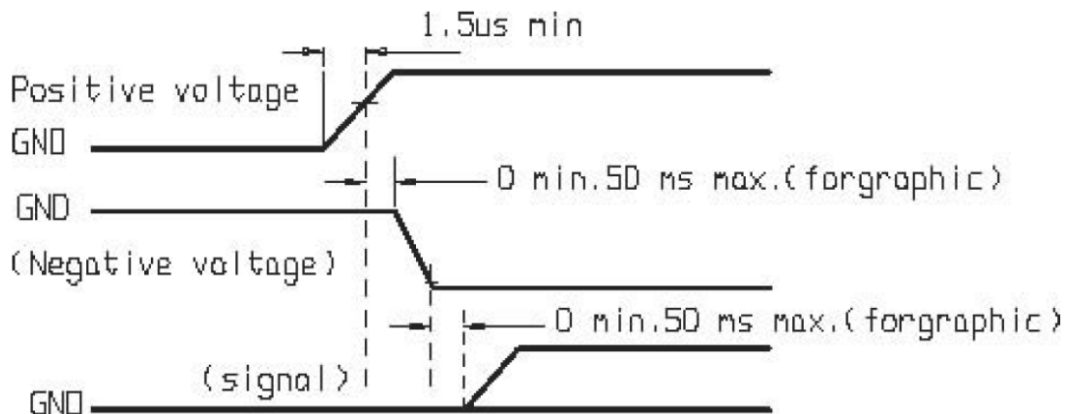

8.3. Safety

- It is recommended to crush damaged or unnecessary LCDs into pieces and wash them off with solvents such as acetone and ethanol, which should later be burned.
- If any liquid leaks out of a damaged glass cell and comes in contact with the hands, wash off thoroughly with soap and water. Limited Warranty.

8.4. Return LCM under Warranty

No warranty can be granted if the precautions stated above have been disregarded. The typical examples of violations are

- Broken LCD glass.
- PCB eyelet is damaged or modified.
- PCB conductors damaged.
- Circuit modified in any way, including the addition of components.
- PCB is tampered with by grinding, engraving or painting varnish.

Module repairs will be invoiced to the customer upon mutual agreement. Modules must be returned with a sufficient description of the failures or defects. Any connectors or cables installed by the customer must be removed completely without damaging the PCB eyelet, conductors and terminals.

9. Revision History



Document Revision

REVISION	DATE	COMMENT
1.2	20/01/2023	Modified datasheet for web-based documentation