

PROPRIETARY INFORMATION
COMPANY CONFIDENTIAL

REV.	ECN. NO.	DESCRIPTION	ENG	DATE
A		INITIAL	Lucky	08/29/17

- CONTACT CURRENT RATING: 1A.
- CONTACT RESISTANCE: 30 mΩ MAX.;
- INSULATION RESISTANCE: 100MΩ MIN.;
- DIELECTRIC WITHSTANDING: 500V AC MIN.;
- DURABILITY: 5,000 CYCLES MIN.;
- CONNECTOR MATING FORCES: 29.4N MAX.;
- CONNECTOR UNMATING FORCES: 2.94N MIN.;

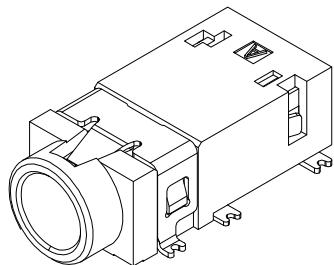
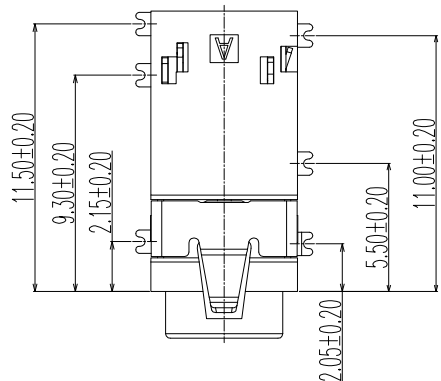

3D VIEW

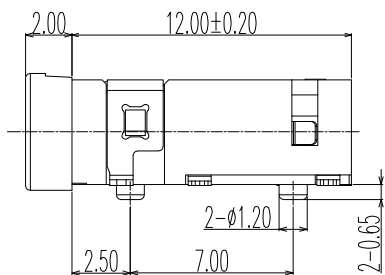
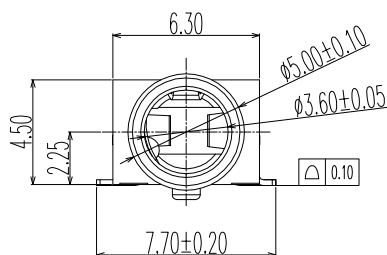

尾部不贴麦拉

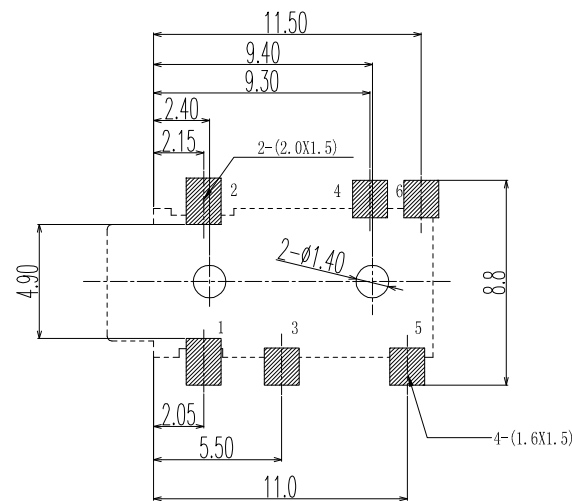
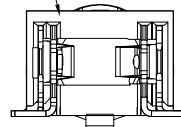

P.C.B LAYOUT
TOP VIEW

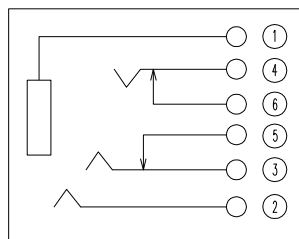
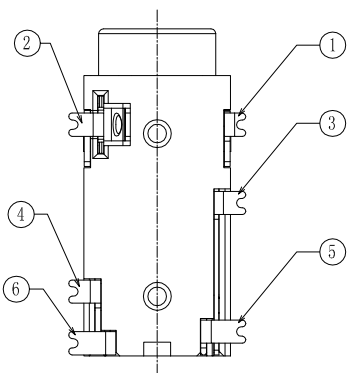

SCHEMATIC

ITEM	NAME	Q'TY	DESCRIPTION	NOTE
7	TERMINAL 6#	1	BRASS; THE BOTTOM OF THE NICKEL,GOLD PLATING ON SOLDER AREA ;	
6	TERMINAL 5#	1		
5	TERMINAL 4#	1	PHOSPHOR BRONZE; NICKEL UNDER PLATING OVERALL,GOLD PLATING ON SOLDER AREA ;GOLD PLATING ON CONTACT AREA	
4	TERMINAL 3#	1		
3	TERMINAL 2#	1	PHOSPHOR BRONZE; THE BOTTOM OF THE NICKEL; THE WHOLE GOLD PLATING.	
2	TERMINAL 1#	1		
1	HOUSING	1	PART COLOR BLACK	

MEASURE POINT:
QUADRANT POINT (QP)
TANGENCY POINT (TP)
INTERSECTION POINT (IP)

UNLESS OTHERWISE SPECIFIED, TOLERANCE:
X. ±0.25
X.x ±0.20
X.xx ±0.15
X.xxx ±0.10
ANGULAR ±3°



DESIGN:	DATE:	TITLE:		
CHECKED:	DATE:	ø3.5mm PHONE JACK H=4.5 mm SMT TYPE CONNECTOR		
APPROVED:	DATE:	PART NO. PJ35A051-F06G1BR-B	REV.: A	SCALE: 1:1
DRAWING NO.	SIZE: A4	SHEET: 1/1	UNIT: mm	

REV.	ECN NO.	DESCRIPTION	DESIGN	DATF
A	XXXXXXX	INITIAL	Kai	2017.11.22

1载带=1000PCS

1外箱=1000PCSX10盘载带=10000PCS

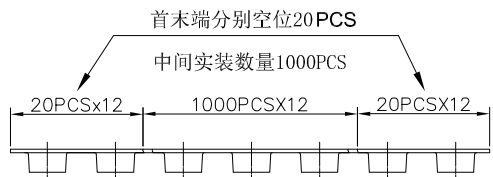

首末端分别空位20PCS
中间实装数量1000PCS

20PCSx12 1000PCSx12 20PCSx12

载带引出方向 →

* 载带包装时请依此引出方向为标准

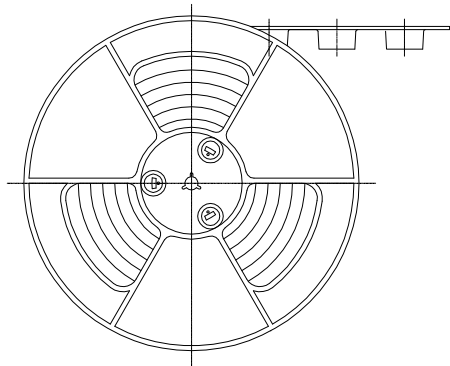

卷盘包装示意

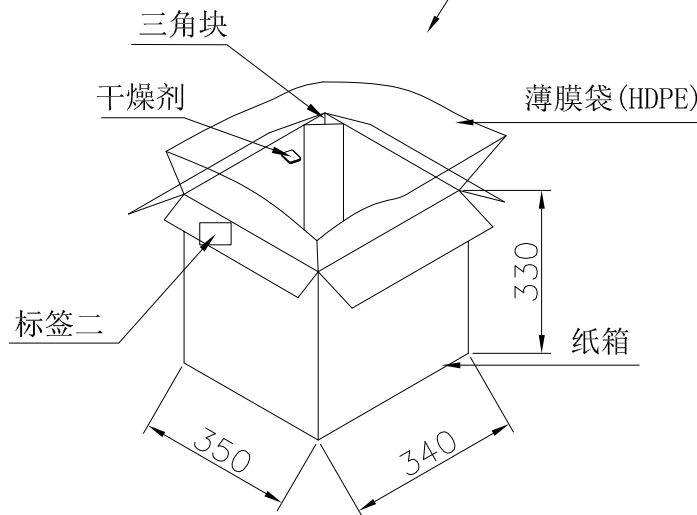
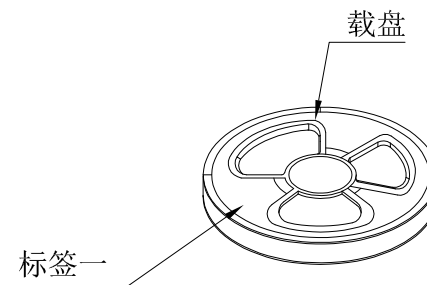
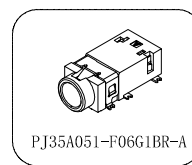
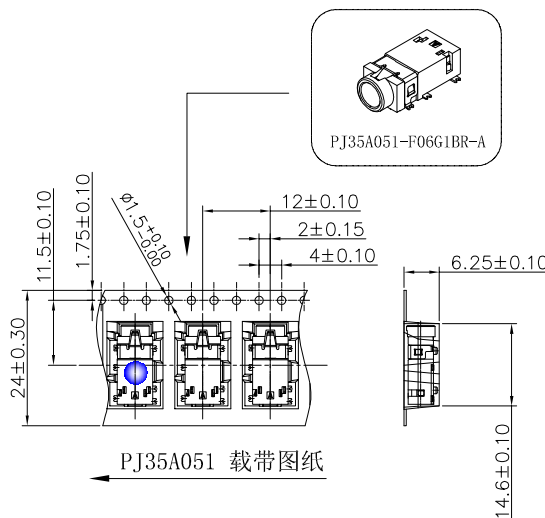

包材名称	材料及厚度 (mm)	规格 (mm)
PJ35A051 载带	P. S(白色透明) T=0.30	12500X24.00X5.55
载盘	HI P. S(蓝色)	Ø330X28.40
自粘带	PET(白色透明)	W=21.30 T=0.06
PE-375X450X0.06-A	PE(白色透明)	770X750X0.035
三角块	A=A+	260X300
ZK-400X400X330-A	K=K t=4	350X340X330

备注:

1. 每箱内必须放干燥剂;
2. 每箱必须用PE带密封包装;
3. 参考《高温材料管理规定》进行作业;
4. 我司标准格式标签或标签按客户要求制作;

UNLESS OTHERWISE SPECIFIED TOLERANCES					
DECIMALS:		ANGLES:			
DIM	TOL	DIM	TOL	DESIGN:	Kai
X.X	±0.20	X.	±1°		2017/11/09
X.XX	±0.10	X.X	±0.5°	CHECK:	/
X.XXX	±0.05	X.XX	—	APPROVED	Lucky
X.XXX	±0.02	X.XXX	—		2017/11/09
				PART NAME:	PHONE JAC
				PART NO.	PJ35A051-F06G1BR-A
REV.	UNIT:	SHEET:			
A	mm	1/1			