

Ordering Information:

A2501WR-XP - ** - *** - *** - ***

1 2 3 4 5

1.Part NO.

2.Style:

(Blank): Type 1

2: Type 2

2.Material:

(Blank): Nylon 66,UL94V-0(White)

LCP: LCP,UL94V-0(Natural)

3.Color:

(Blank): see section 2 materia

BK: Black RD: Red

YL: Lemon yellow

4.Finish:

(Blank): Tin over Nickel

G: Gold over Nickel

5.Packing:

(Blank): Bag

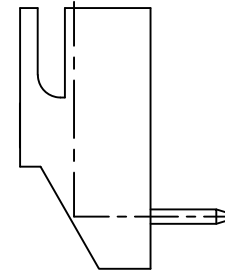
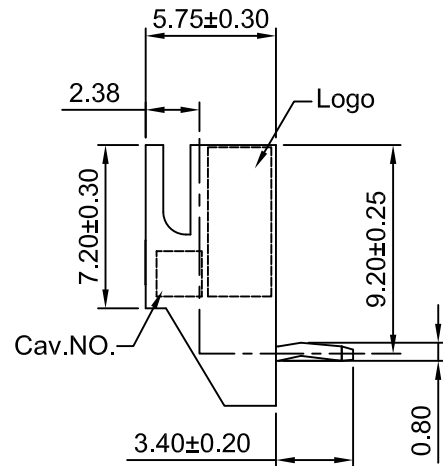
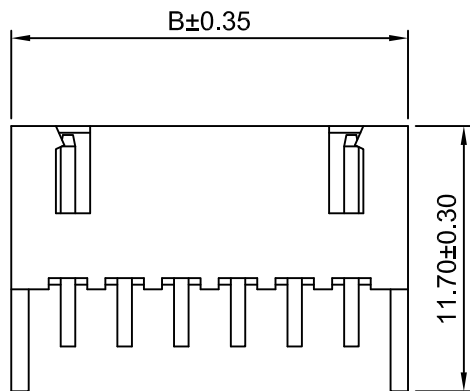
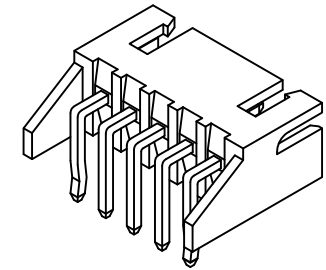

3P~20P

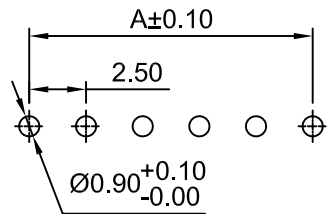

P.C.B LAYOUT
TOLERANCE:±0.05

SPECIFICATIONS:

Current Rating: 3A AC,DC

Voltage Rating: 250V AC,DC

Temperature Range: -40°C ~ +105°C

Contact Resistance: 10mΩ Max

Insulation Resistance: 1000MΩ Min

Withstanding Voltage: 1000V AC/minute

Pin Material: Brass

Ordering Information & Dimensions

Circuits	Dimensions(mm)		Circuits	Dimensions(mm)	
	A	B		A	B
2P	2.50	7.50	12P	27.50	32.50
3P	5.00	10.00	13P	30.00	35.00
4P	7.50	12.50	14P	32.50	37.50
5P	10.00	15.00	15P	35.00	40.00
6P	12.50	17.50	16P	37.50	42.50
7P	15.00	20.00	17P	40.00	45.00
8P	17.50	22.50	18P	42.50	47.50
9P	20.00	25.00	19P	45.00	50.00
10P	22.50	27.50	20P	47.50	52.50
11P	25.00	30.00			

CJTconn CHANGJIANG CONNECTORS CO.,LTD.

Unit	Scale	Sheet	TITLE
mm	3:1	1 of 1	2.50mm PITCH RIGHT-ANGLE WAFER
DRAWN	CHK'D	APPR'D	
Haisen Li	Diankui Wan	Jack Yin	
General Tolerances			THIRD ANGLE PROJECTION
A1	JL-GC-ECN00474	2024.12.18	DRAWING NO.
A0	NEW RELEASE	2005.05.10	
REV	DESCRIPTION	DATE	A2501WR-XP

REV	DESCRIPTION	DATE
A1	JL-GC-ECN00474	2024.12.18
A0	NEW RELEASE	2005.05.10

General Tolerances	THIRD ANGLE PROJECTION
x.x±0.25 x.xx±0.20 x.xxx±0.15 ANGLES ±1°	

REV A1