

Parameters Subject to Change Without Notice

## DESCRIPTION

The JW<sup>®</sup>5121 is a current mode monolithic buck switching regulator. Operating with an input range of 4.5V~60V, the JW5121 delivers 2A of continuous output current with an integrated high side N-Channel MOSFET. At light loads, the regulator operates in low frequency to maintain high efficiency and low output ripple. Current mode control provides tight load transient response and cycle-by-cycle current limit.

The JW5121 guarantees robustness with short-circuit protection, thermal protection, current run-away protection, and input under voltage lockout.

The JW5121 is available in 8-pin ESOP and 10-pin EMSOP package, which provides a compact solution with minimal external components.

*Company's Logo is Protected, "JW" and "JOULWATT" are Registered*

*Trademarks of JoulWatt technology Inc.*

## FEATURES

- 4.5V to 60V operating input range
- 2A output current
- High efficiency at light load
- Internal Soft-Start
- Adjustable switching frequency
- Input under voltage lockout
- Current run-away protection
- Short circuit protection
- Thermal protection
- Available in ESOP8 and EMSOP10package

## APPLICATIONS

- Distributed Power Systems
- Automotive Systems
- High Voltage Power Conversion
- Industrial Power Systems
- Battery Powered Systems

## TYPICAL APPLICATION

5V/2A Step Down Regulators  
C3

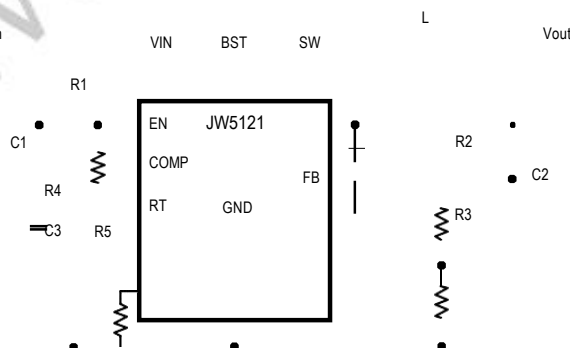

### ORDER INFORMATION

DEVICE <sup>1)</sup>	PACKAGE	TOP MARKING <sup>2)</sup>
JW5121ESOP#TRPBF	ESOP8	JW5121 YWLLLLL
JW5121EMSOP#TRPBF	EMSOP10	JW5121 YWLLLLL

#### Notes:

- 1) JW # TRPBF I PB Free Tape and Reel(If " TR " is not shown, it means tube)  
 Package Code Part No. YWLLLLL
- 2) Line1: JWPNC D Product code of JWXXXX Line2: Joulwatt LOGO Lot number  
 Week code Year code

### PIN CONFIGURATION

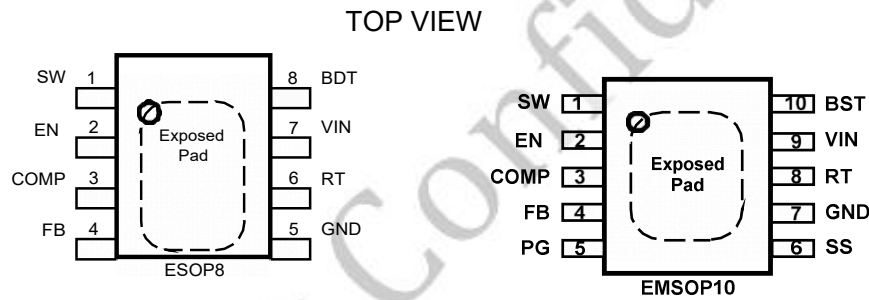

### ABSOLUTE MAXIMUM RATING<sup>1)</sup>

VIN, EN, SW Pin.....	V to 66V
BST Pin.....	SW-0.3V to SW+5V
All other Pins.....	V to 6V
Junction Temperature <sup>2) 3)</sup> .....	150°C
Lead Temperature.....	260°C
Storage Temperature.....	-65°C to +150°C

### RECOMMENDED OPERATING CONDITIONS

Input Voltage VIN.....	V to 60V
Output Voltage Vout.....	V to VIN-3V
Operating Junction Temperature.....	-40°C to 125°C

### THERMAL PERFORMANCE<sup>4)</sup>

	$\theta_{JA}$	$\theta_{Jc}$
ESOP8.....	50... 10°C/W	
EMSOP10.....	60... 30°C/W	

Note:

- 1) Exceeding these ratings may damage the device.
- 2) The JW5121 guarantees robust performance from -40°C to 150°C junction temperature. The junction temperature range specification is assured by design, characterization and correlation with statistical process controls.
- 3) The JW5121 includes thermal protection that is intended to protect the device in overload conditions. Thermal protection is active when junction temperature exceeds the maximum operating junction temperature. Continuous operation over the specified absolute maximum operating junction temperature may damage the device.
- 4) Measured on JESD51-7, 4-layer PCB.

JoulWatt Confidential

**ELECTRICAL CHARACTERISTICS**

$V_{IN} = 12V, T_A = 25^{\circ}C, \text{ unless otherwise stated.}$

Item	Symbol	Condition	Min.	Typ.	Max.	Units
$V_{IN}$ Under voltage Lockout Threshold	$V_{IN\_MIN}$	$V_{IN}$ rising		3.5		V
$V_{IN}$ Under voltage Lockout Hysteresis	$V_{IN\_MIN\_HYST}$			300		mV
Shutdown Supply Current	$I_{SD}$	$V_{EN}=0V$		0.1	1	$\mu A$
Supply Current	$I_Q$	$V_{EN}=5V, V_{FB}=1V$		65	90	$\mu A$
Feedback Voltage	$V_{FB}$	$4.7V < V_{IN} < 60V$	784	800	816	mV
Power Switch Resistance <sup>5)</sup>	$R_{DS(ON)T}$			160		m $\Omega$
Power Switch Leakage Current	$I_{LEAK}$	$V_{IN}=60V, V_{EN}=0V, V_{SW}=60V$			1	$\mu A$
Power Switch Current Limit	$I_{LIM}$	Minimum Duty Cycle	3.6	4.2	5	A
Error Amplifier Transconductance <sup>5)</sup>	GEA			300		$\mu A/V$
Error Amplifier Voltage Gain <sup>5)</sup>				1000		V/V
Maximum COMP Sourcing Current	$I_{COMP\_MAX\_OUT}$	$V_{comp} = 1V$		14		$\mu A$
Maximum COMP Sinking Current	$I_{COMP\_MAX\_IN}$	$V_{comp} = 3V$		14		$\mu A$
Comp to Current Sense Transconductance <sup>5)</sup>	GCS			1.33		A/V
Switch Frequency	$f_{SW}$	$R_{RT}=330k$	160	200	240	kHz
Switch Frequency Range	$f_{SW}$		100		2000	kHz
Minimum On Time	$T_{ON\_MIN}$			100		ns
Minimum Off Time	$T_{OFF\_MIN}$	$V_{FB}=0V$		100		ns
Soft-start Time <sup>5)</sup>	$T_{SS}$	$0V < V_{FB} < 0.8V$		0.8		ms
Power good lower threshold	PGDlth	FB falling		88%		
Power good upper threshold	PGDuth	FB rising		112%		
Power good delay	PGDdly	PG from low to high		1		ms
EN shut down threshold voltage	$V_{EN\_TH}$	$V_{EN}$ rising, $FB=0.6V$	1.18	1.3	1.42	V
EN shut down hysteresis	$V_{EN\_HYST}$			180		mV
Thermal Shutdown <sup>5)</sup>	$T_{TSD}$			150		$^{\circ}C$
Thermal Shutdown hysteresis <sup>5)</sup>	$T_{TSD\_HYST}$			15		$^{\circ}C$

**Note:**

5) Guaranteed by design.

**PIN DESCRIPTION**

Pin		Name	Description
ESOP8	EMSOP10		
1	1	SW	SW is the switching node that supplies power to the output. Connect the output LC filter from SW to the output load.
2	2	EN	Drive EN pin high to turn on the regulator and low to turn off the regulator.
3	3	COMP	Compensation. Output of the GM error amplifier. Control loop frequency compensation is applied to this pin.
4	4	FB	Output feedback pin. FB senses the output voltage and is regulated by the control loop to 800mV. Connect a resistive divider at FB.
5	7	GND	Ground.
6	8	RT	Switching Frequency Program Input. Connect a resistor from this pin to ground to set the switching frequency.
7	9	VIN	Input voltage pin. VIN supplies power to the IC. Connect a 4.7V to 60V supply to VIN and bypass VIN to GND with a suitably large capacitor to eliminate noise on the input to the IC.
8	10	BST	Bootstrap pin for top switch.
	5	PG	Open drain output for power-good flag. Use a 10kΩ to 100kΩ pull-up resistor to logic rail or other DC voltage no higher than 5V.
	6	SS	Soft-start control pin. Leave floating for internal soft-start slew rate. Connect to a capacitor to extend soft start time.

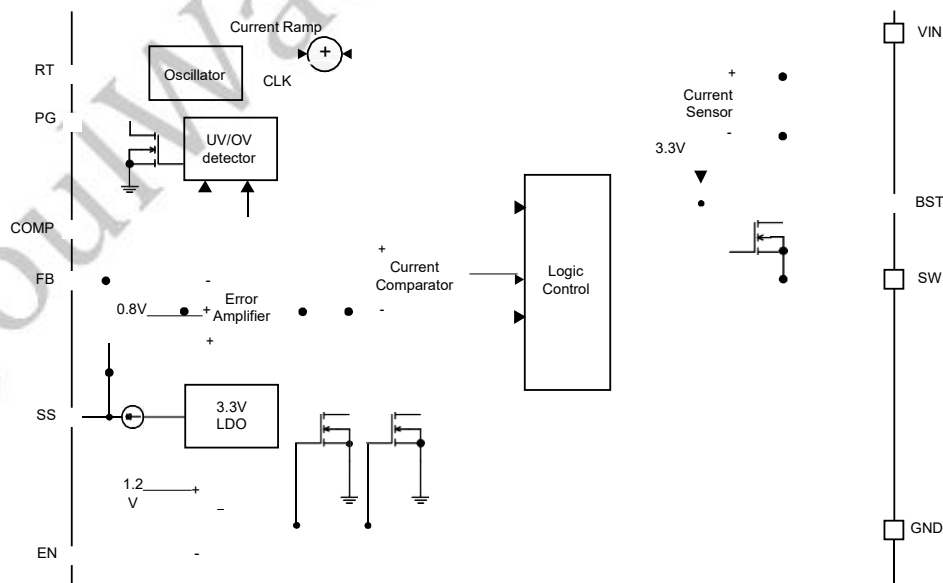
**BLOCK DIAGRAM**

## FUNCTIONAL DESCRIPTION

The JW5121 is a asynchronous, current-mode, step-down regulator. It regulates input voltages from 4.5V to 60V down to an output voltage as low as 0.8V, and is capable of supplying up to 2A of load current.

### Current-Mode Control

The JW5121 utilizes current-mode control to regulate the output voltage. The output voltage is measured at the FB pin through a resistive voltage divider and the error is amplified by the internal trans conductance error amplifier. The voltage feedback loop is compensated by an external RC network connected between the COMP pin and GND pin.

Output of the error amplifier  $V_{COMP}$  is compared with the switch current measured internally to control the output current.

### PFM Mode

The JW5121 operates in PFM mode at light load. In PFM mode, switch frequency decreases when load current drops to boost power efficiency at light load by reducing switch-loss, while switch frequency increases when load current rises, minimizing output voltage ripples.

### Shut-Down Mode

The JW5121 shuts down when voltage at EN pin is below 0.3V. The entire regulator is off and the supply current consumed by the JW5121 drops below 0.1uA.

### Power Switch

N-Channel MOSFET switches are integrated on the JW5121 to down convert the input voltage to the regulated output voltage. Since the top MOSFET needs a gate voltage great than the input voltage, a boost capacitor connected

between BST and SW pins is required to drive the gate of the top switch. The boost capacitor is charged by the internal 3.3V rail when SW is low.

### Vin Under-Voltage Protection

A resistive divider can be connected between Vin and ground, with the central tap connected to EN, so that when Vin drops to the pre-set value, EN drops below 1.2V to trigger input under voltage lockout protection.

### Internal Soft-start

Soft-start is designed in JW5121 to prevent the converter output voltage from overshooting during startup and short-circuit recovery. When the chip starts, the internal circuit generates a soft-start voltage (SS) ramping up from 0V to 1.2V. When it is less than the VREF, SS overrides VREF and the error amplifier uses SS as the reference. When SS exceeds VREF, VREF regains control.

### Switching Frequency

The switching frequency of JW5121 can be programmed by the resistor  $R_{RT}$  from the RT pin and GND pin. The frequency can be calculated by the following equation,

$$f_{sw}(kHz) = 10^6 / (13.8 \times R_{RT} + 100)$$

where the unit of  $R_{RT}$  is k $\Omega$ .

For example, for  $f_{sw} = 200kHz$ ,  $R_{RT} = 330 k\Omega$ .

### Output Current Run-Away Protection

At start-up, due to the high voltage at input and low voltage at output, current inertia of the output inductance can be easily built up, resulting in a large start-up output current. A valley current limit is designed in the JW5121 so that only when output current drops below the

valley current limit can the top power switch be turned on. By such control mechanism, the output current at start-up is well controlled.

### Output Short Protection

When output is shorted to ground, output current rapidly reaches its peak current limit and the top power switch is turned off. Right after the top power switch is turned off, the bottom power switch is turned on and stay on until the output current falls below the valley current limit. When output current is below the valley current limit, the top power switch will be turned on again and if the output short is still present, the top power switch is turned off when the peak current limit is reached and the bottom power switch is turned on. This cycle goes on until the output short is removed and the regulator comes into normal operation again.

### Power Good

The JW5121 has power-good (PG) output. The PG pin is the open drain of a MOSFET. Connect to a voltage source (such as Vout) through a resistor. When the output voltage becomes

within  $\pm 12\%$  of the target value, internal comparators detect power good state and the power good signal becomes high. If the feedback voltage goes under or higher 12% of the target value, the power good signal becomes low.

### RT Short Protection

If the RT pin is detected to be short to ground, JW5121 is not allowed to switch to prevent abnormal operation state. The regulator can be reactivated again when the short condition at the RT pin is removed

### Thermal Protection

When the temperature of the JW5121 rises above  $150^{\circ}\text{C}$ , it is forced into thermal shut-down.

Only when core temperature drops below  $135^{\circ}\text{C}$  can the regulator becomes active again.

### PACKAGE OUTLINE

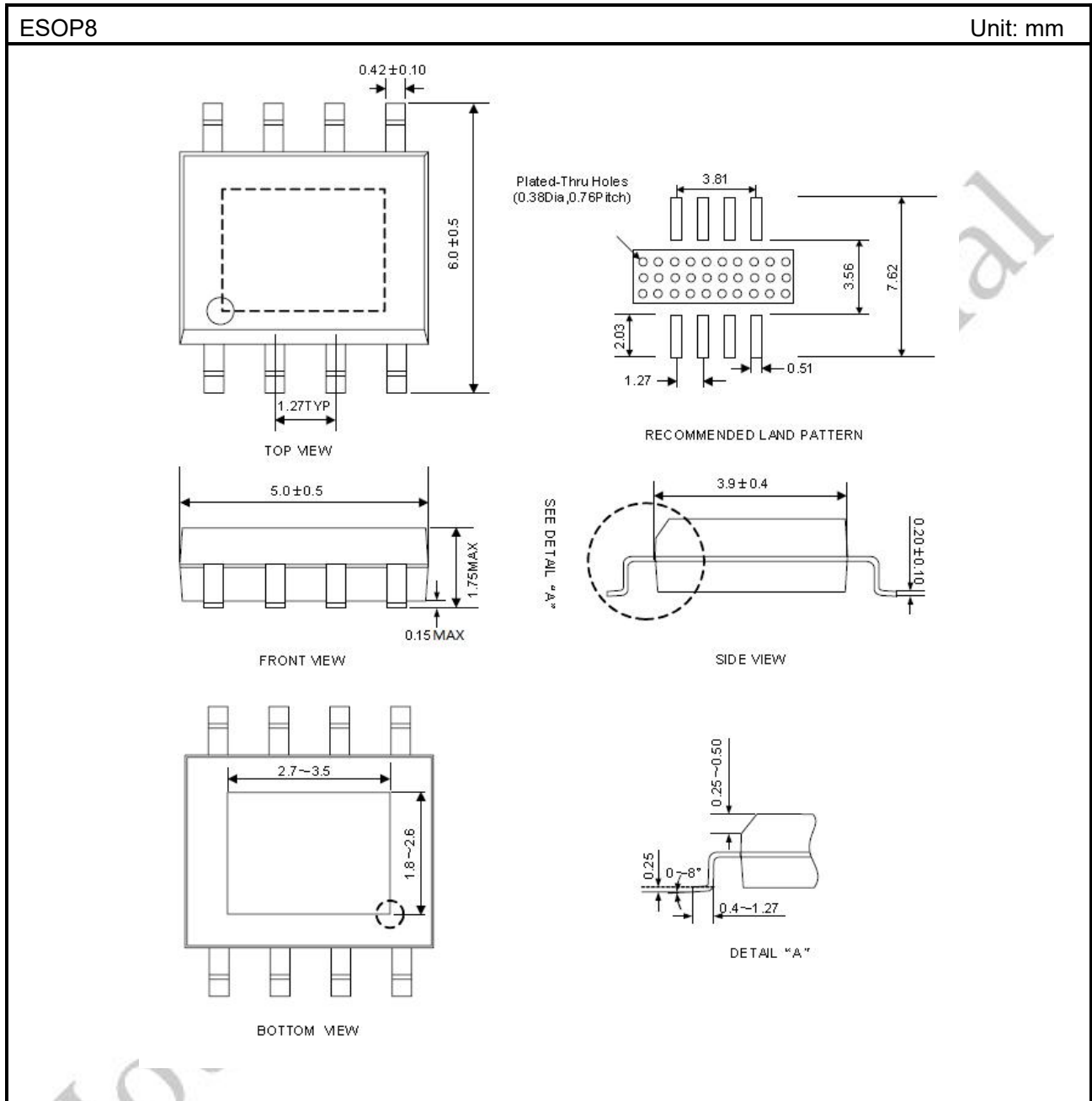



EMSOP10 UNIT: mm

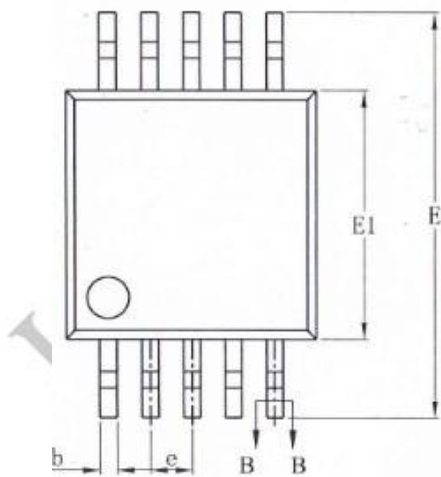
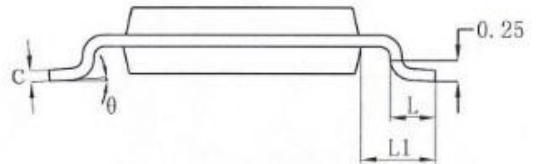
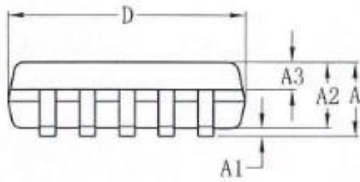
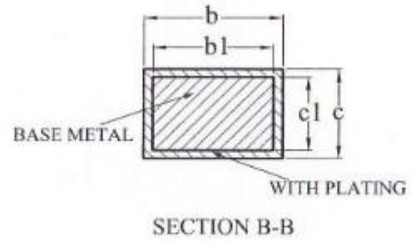
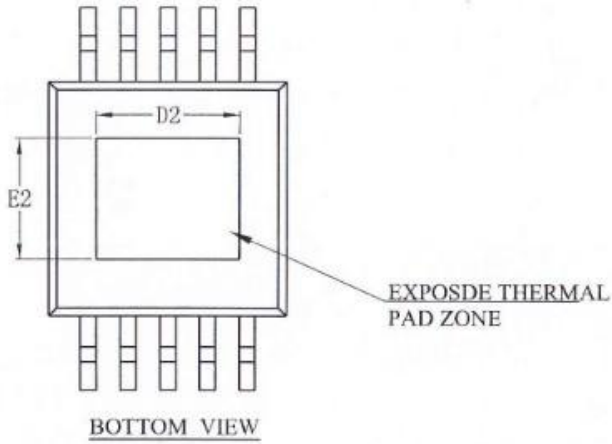

SYMBOL	MILLIMETER		
	MIN	NOM	MAX
A	—	—	1.10
A1	0.05	—	0.15
A2	0.75	0.85	0.95
A3	0.30	0.35	0.40
b	0.18	—	0.26
b1	0.17	0.20	0.23
c	0.15	—	0.19
c1	0.14	0.15	0.16
D	2.90	3.00	3.10
E	4.70	4.90	5.10
E1	2.90	3.00	3.10
e	0.50BSC		
L	0.40	—	0.70
L1	0.95REF		
θ	0	—	8°

Size (mil)	D2	E2
LF Size (mil)	1.80REF	1.55REF

### IMPORTANT NOTICE

- Joulwatt Technology Inc. reserves the right to make modifications, enhancements, improvements, corrections or other changes without further notice to this document and any product described herein.
- Any unauthorized redistribution or copy of this document for any purpose is strictly forbidden.
- Joulwatt Technology Inc. does not warrant or accept any liability whatsoever in respect of any products purchased through unauthorized sales channel.

JoulWatt Confidential

*Copyright © 2015 JW5121 Incorporated.*

*All rights are reserved by Joulwatt Technology Inc.*