

## NPN Silicon Power Transistor

### Absolute Maximum Ratings ( $T_a = 25\text{ }^\circ\text{C}$ )

Parameter	Symbol	Value	Unit
Collector to Base Voltage	$V_{CBO}$	40	V
Collector to Emitter Voltage	$V_{CEO}$	30	V
Emitter to Base Voltage	$V_{EBO}$	5	V
Collector Current	$I_C$	3	A
Peak Collector Current (t = 10 ms)	$I_{CP}$	7	A
Total power dissipation ( $T_a = 25\text{ }^\circ\text{C}$ )	$P_{tot}$	1	W
Total power dissipation ( $T_c = 25\text{ }^\circ\text{C}$ )	$P_{tot}$	10	W
Junction Temperature	$T_j$	150	$^\circ\text{C}$
Storage Temperature Range	$T_{stg}$	- 55 to + 150	$^\circ\text{C}$

### Characteristics at $T_a = 25\text{ }^\circ\text{C}$

Parameter	Symbol	Min.	Typ.	Max.	Unit
DC Current Gain at $V_{CE} = 2\text{ V}$ , $I_C = 20\text{ mA}$ at $V_{CE} = 2\text{ V}$ , $I_C = 1\text{ A}$ Current Gain Group	R	30	-	-	-
	Q	60	-	120	-
	P	100	-	200	-
	E	160	-	320	-
			200	-	400
Collector Base Cutoff Current at $V_{CB} = 30\text{ V}$	$I_{CBO}$	-	-	1	$\mu\text{A}$
Emitter Base Cutoff Current at $V_{EB} = 3\text{ V}$	$I_{EBO}$	-	-	1	$\mu\text{A}$
Collector Emitter Saturation Voltage at $I_C = 2\text{ A}$ , $I_B = 0.2\text{ A}$	$V_{CE(sat)}$	-	-	0.5	V
Base Emitter Saturation Voltage at $I_C = 2\text{ A}$ , $I_B = 0.2\text{ A}$	$V_{BE(sat)}$	-	-	2	V
Gain Bandwidth Product at $V_{CE} = 5\text{ V}$ , $I_C = 0.1\text{ A}$	$f_T$	-	90	-	MHz
Output Capacitance at $V_{CB} = 10\text{ V}$ , $f = 1\text{ MHz}$	$C_{ob}$	-	45	-	pF

TYPICAL CHARACTERISTICS (Ta=25°C)

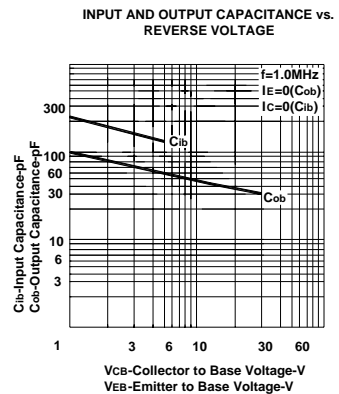
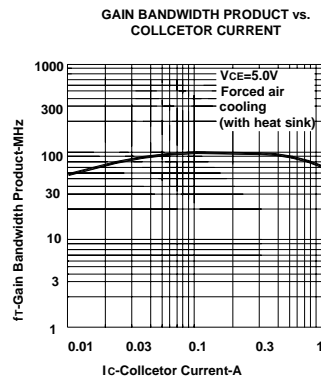
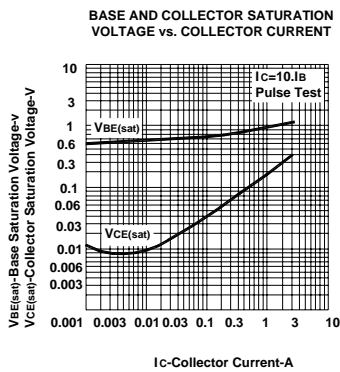
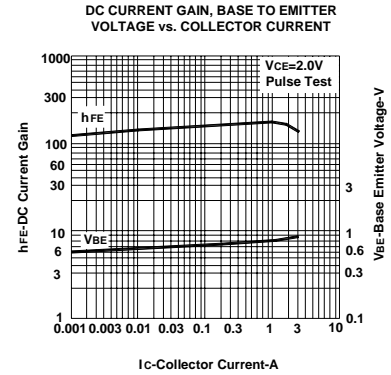
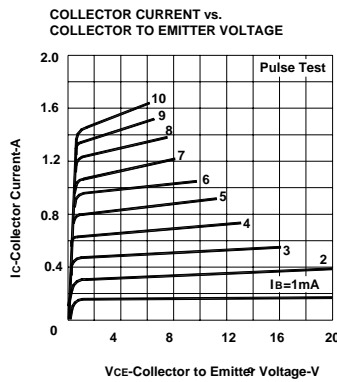
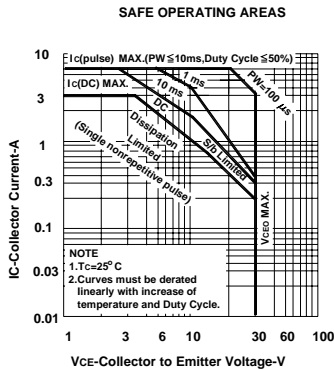
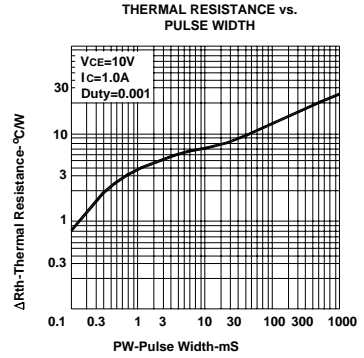
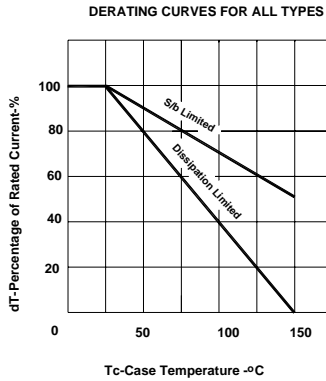
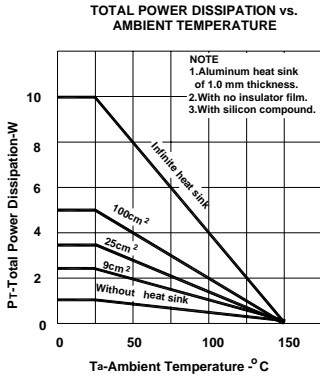

**SOT-89 PACKAGE OUTLINE**

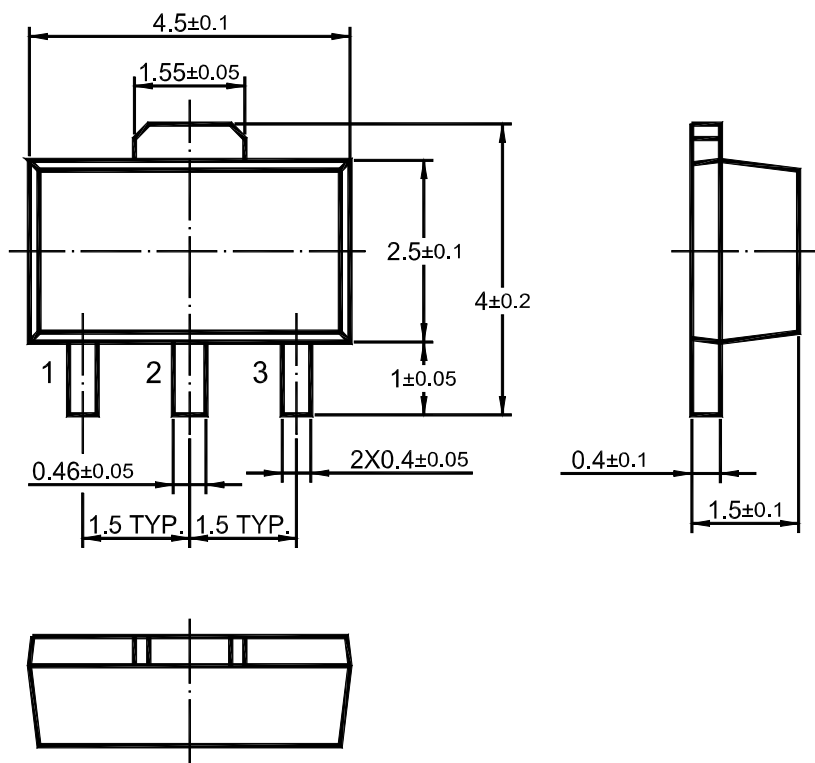

Dimensions in mm