

Notes:

1. MATERIAL SPECIFICATION:
 - 1.1. HOUSING:LCP+40%GF,UL94V-0,COLOR:BLACK.
 - 1.2. CONTACT:COPPER ALLOY C1065,T=0.15mm,
 - 1.3. PEG:S50C,T=0.20mm.
2. PLATING SPECIFICATION:
 - 2.1. CONTACT:50u" MIN.NICKEL UNDER PLATING OVER ALL.PLATING ON SOLDER AREA:SEE TABLE GOLD PLATING ON CONTACT AREA:SEE TABLE
 - 2.2. PEG:50u" MIN. NICKEL UNDER PLATING OVER ALL. 80u" MIN. MATTE TIN PLATING ON SOLDER AREA.
3. HF COMPLIANT, RoHS COMPLIANT.
4. DATE CODE: XX XX XX
 DAY
 WEEK
 YEAR
5. MECHANICAL PERFORMANCE:
 - 5.1. DURABILITY: SEE TABLE
6. ELECTRICAL PERFORMANCE:
 - 6.1. CURRENT: 0.5A PER PIN.
 - 6.2. LLCR: INITIAL 55mΩ MAX.;FINAL ΔLLCR=20mΩ MAX.
7. IR REFLOW:
 THE TEMPERATURE SHALL BE 260°C MAINTAINING 10 SECONDS.



深圳市华宇创精密电子有限公司

TOLERANCE: X.X ±0.30 X.XX ±0.25 X.XXX ±0.15 X' ±2' X.X' ±0.5'	DRAWN BY : 陈一鸣	DATE : 2014-02-23	PART NAME: 0.5MM PITCH M.2 H5.5 (KEY M)
	CHECKED BY: 马跃	DATE : 2014-02-23	PART NO. HYCW17M-05NGFF-550B
UNIT: mm [inch] SCALE:1:1 SIZE: A4	APPROVED BY: 柯南	DATE : 2014-02-23	DRAW NO: HYC-1903071621
			SHEET NO. 1 OF 1

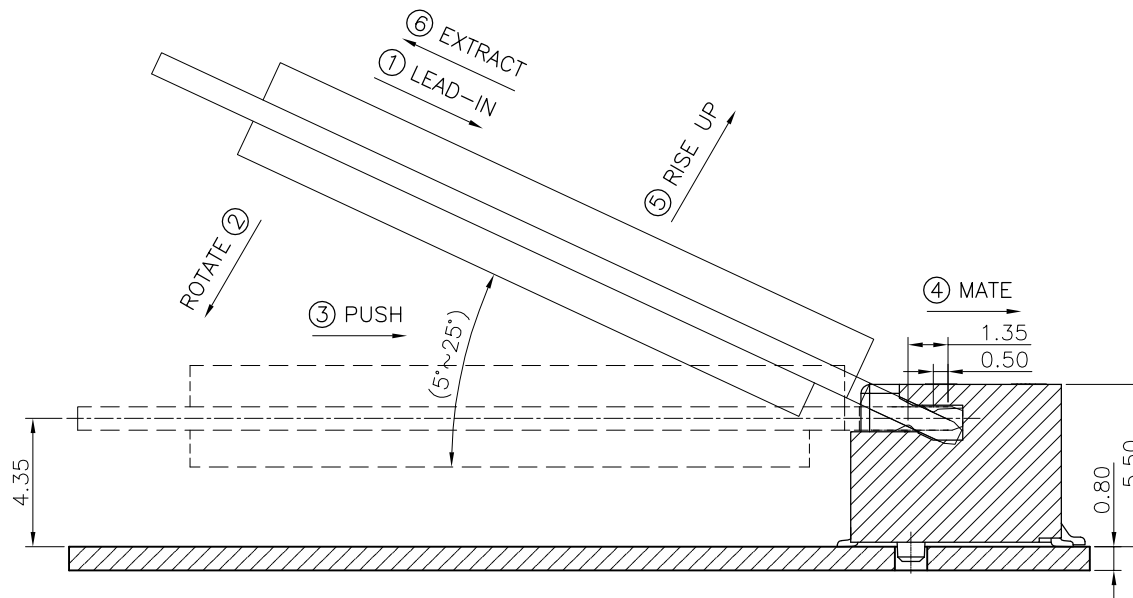
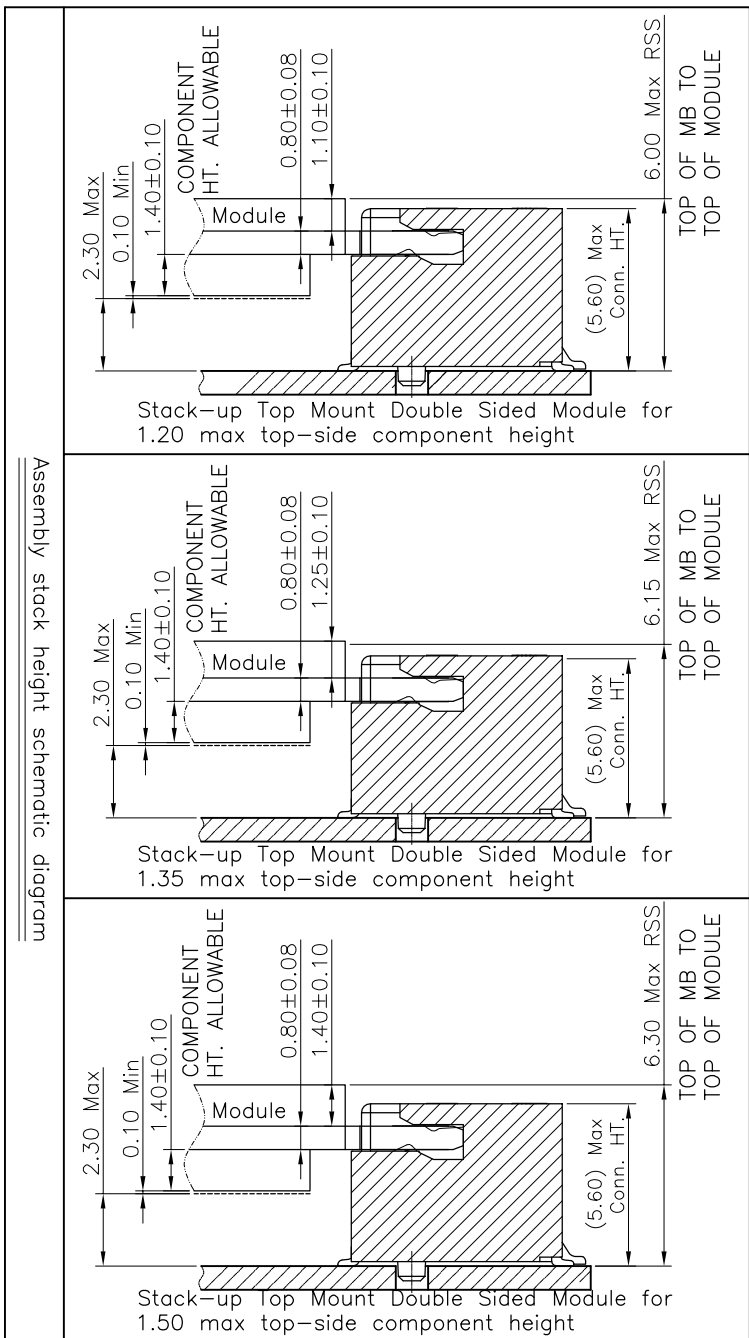

HOW TO MATE AND EXTRACT

MATE: ① → ④

EXTRACT: ⑤ → ⑥

NOTE: Mating force will generate from step 3 to step 4.



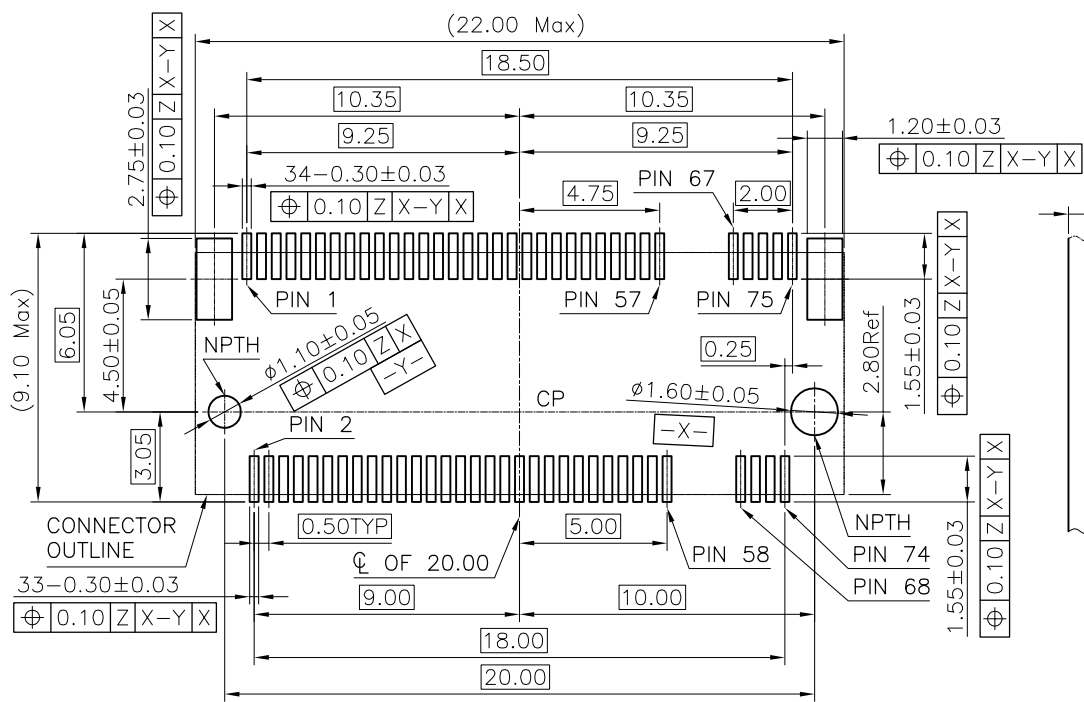
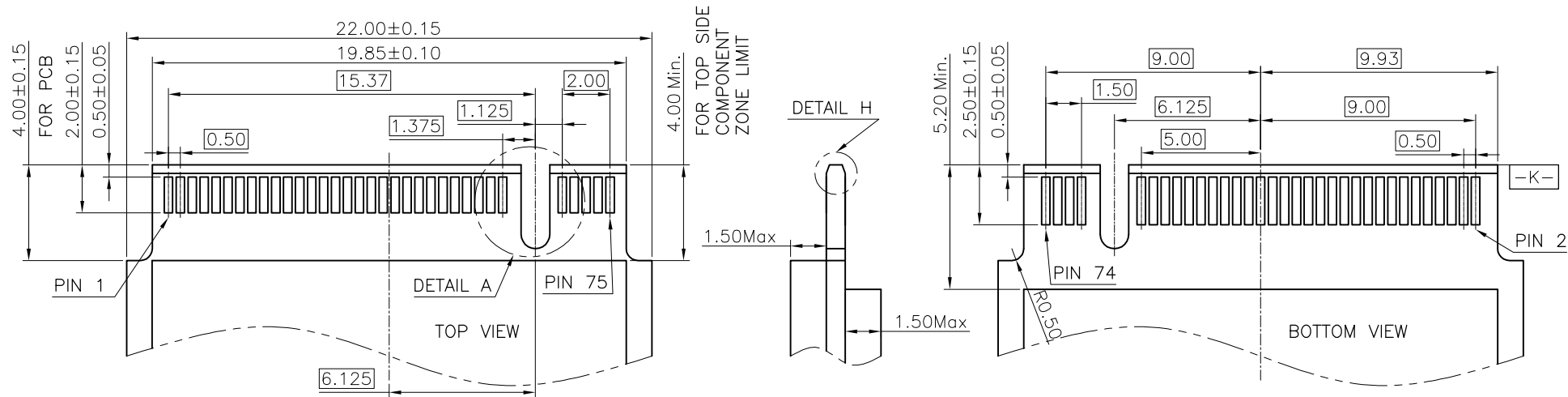

深圳市华宇创精密电子有限公司

TOLERANCE: X.X ±0.30 X.XX ±0.25 X.XXX ±0.15 X' ±2' X.X' ±0.5'	DRAWN BY : 陈一鸣	DATE : 2014-02-23	PART NAME: 0.5MM PITCH M.2 H5.5 (KEY M)
	CHECKED BY: 马跃	DATE : 2014-02-23	PART NO. HYCW17M-05NGFF-550B
UNIT: mm [inch] SCALE:1:1 SIZE: A4	APPROVED BY: 柯南	DATE : 2014-02-23	DRAW NO: HYC-1903071621
			SHEET NO. 1 OF 1

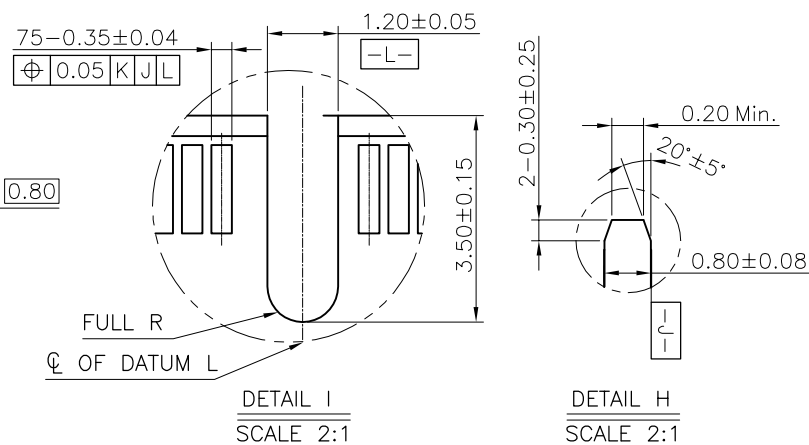

RECOMMENDED PCB LAYOUT(TOP VIEW)
DEFAULT TOLERANCE ±0.05MM



 深圳市华宇创精密电子有限公司			
TOLERANCE: X.X ±0.30 X.XX ±0.25 X.XXX ±0.15 X' ±2' X.X' ±0.5'	DRAWN BY : 陈一鸣	DATE : 2014-02-23	PART NAME: 0.5MM PITCH M.2 H5.5 (KEY M)
	CHECKED BY: 马跃	DATE : 2014-02-23	PART NO. HYCW17M-05NGFF-550B
UNIT: mm [inch]	APPROVED BY: 柯南	DATE : 2014-02-23	DRAW NO: HYC-1903071621
SCALE: 1:1 SIZE: A4			SHEET NO. 1 OF 1

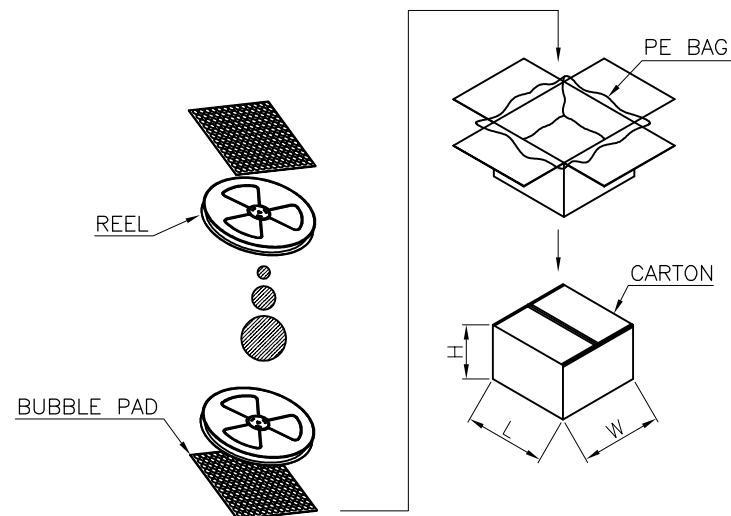
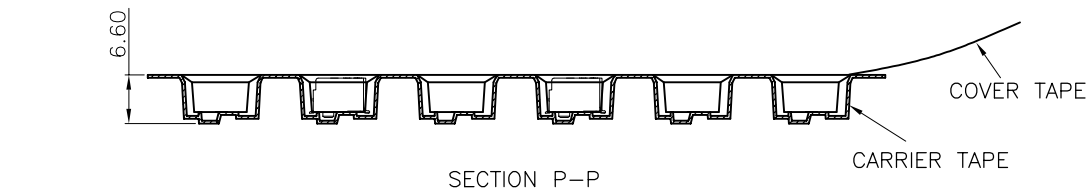
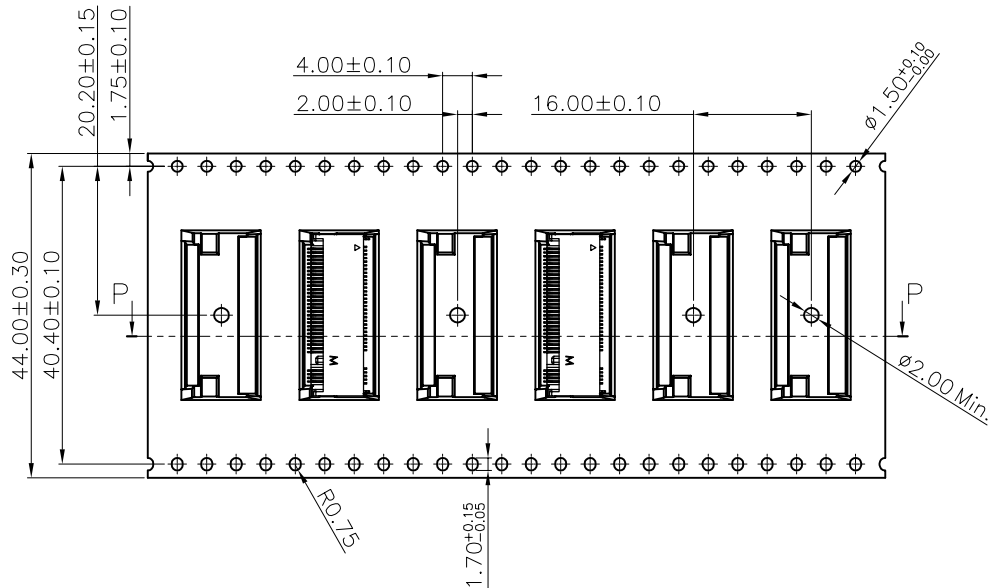
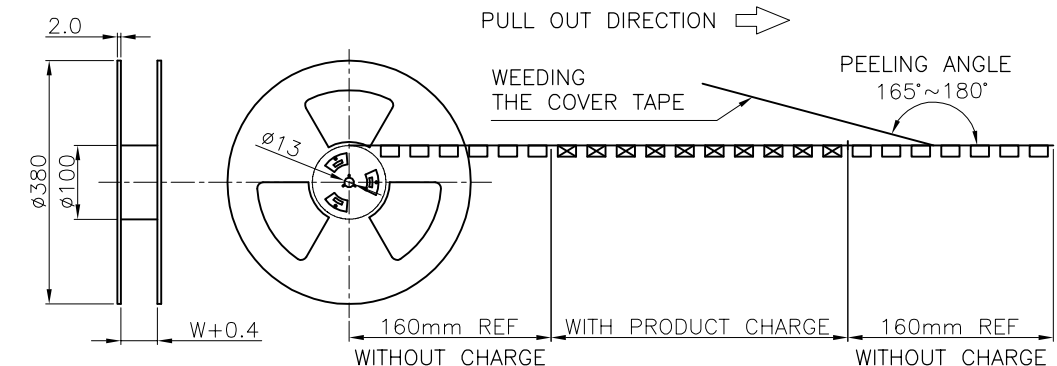

750	4500
PCS/REEL	PCS/CARTON

深圳市华宇创精密电子有限公司

TOLERANCE: X.X ±0.30 X.XX ±0.25 X.XXX ±0.15 X.' ±2' X.X' ±0.5'	DRAWN BY : 陈一鸣	DATE : 2014-02-23	PART NAME: 包装图	
	CHECKED BY: 马跃	DATE : 2014-02-23	PART NO.	_____
APPROVED BY: 柯南	DATE : 2014-02-23	MOLD NO.	_____	
UNIT: mm [inch] SCALE:1:1 SIZE: A4		DRAW NO:		
		SHEET NO.	1 OF 1	