



## 产品规格承认书

# Product Specification for Approval

客户名: 湖南华秋数字科技有限公司  
Customer: \_\_\_\_\_

产品品名: X1型金属化聚丙烯膜抑制电源电磁干扰电容器  
Description: X1 Series Metallized polypropylene film interference suppression capacitor

规格型号: X1-224K440VAC  
Specifications: \_\_\_\_\_

圣融达料号: MP1224K44E3R800  
Sincerity P/N: \_\_\_\_\_

客户料号: \_\_\_\_\_  
Customer P/N: \_\_\_\_\_

产品品牌: 圣融达 (SRD)  
Product Brands: \_\_\_\_\_

制作日期: 2024-12-18  
Production Date: \_\_\_\_\_

客户承认 Customer's Approval			圣融达承认 Sincerity Approval		
接收 Receive	审核 Checked	批准 Approved	制作 Producer	审核 Checked	批准 Approved
			石海珍	谢宇	 * 

电话Tel: +86-755-84251666 84251168 手机Cell: +86-13534221536

邮箱Email: sales@srdkj.com, 网址Http://www.srdkj.com

地址: 中国广东省深圳市龙岗区平湖街道新力路36号圣融达科技园

Add: No. 36, Xinli Rd., Pinghu Street, Longgang District, Shenzhen 518111 Guangdong, China

\* 本规格书归深圳圣融达科技有限公司版权所有, 未经许可, 不得复制或提供给第三方。请贵公司承认此规格书后并及时回传该规格书电子档文件或者复印件, 作为本公司合同技术评审依据。

\* This specification is the copyright of Shenzhen Sincerity technology co., ltd. it cannot be copied or provided to a third party without permission. Please acknowledge the specification book and send back the electronic document or copy of the specification in time as the basis for the technical review of the contract.

## 修改记录

## Change Record

序号 NO	修改日期 Change Date	修改内容 Change Content	修改原因 Change Reason

**MKP/MPX -X1型金属化聚丙烯膜抑制电源电磁干扰电容器 (X1)**  
**MKP/MPX -X1 Series Metallized polypropylene film interference suppression capacitor (Class X1)**

**1、产品特点及主要用途Product characteristics and application**

阻燃塑胶外壳封装，优异的阻燃性能，广泛用于电源跨线路等抗干扰场合产品损耗小，适用于电源跨线抗干扰电路

Excellent flame retardant performance, Widely applied as across line Interference Suppression field, suitable for across-the-line interference suppression circuit.

**2、外形图Outline Drawing**

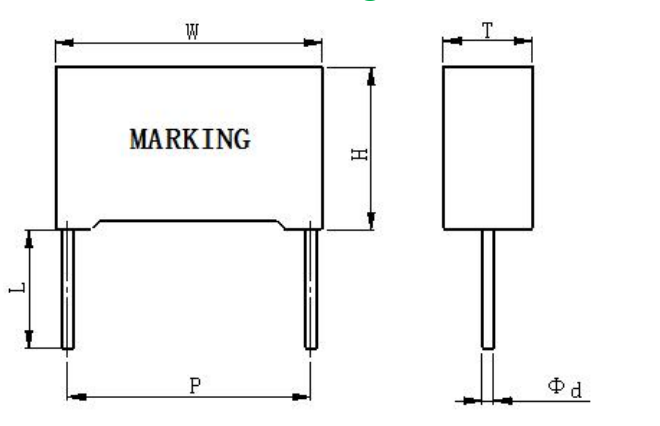

**标志示例Marking Example**



**3、产品尺寸及性能参数: Product Dimension and Characteristic Data**

圣融达料号 SRD P/N	客户料号 Customer P/N	额定电压 Rated Voltage	标称容量 Cap	容量偏差 Tolerance	外形尺寸(mm) Dimension(mm)					
					W ±0.5	T ±0.5	H ±0.5	P ±0.5	d ±0.05	L min
MP1224K44E3R800		440vac	0.22μF	K(±10%)	26.5	8.5	17	22.5	0.8	13
备注:	SRD 灰壳									

**4、技术参数Specification**

参照标准Reference Standard	GB/T 6346.14-2015、IEC 60384-14		
产品类别Product category	X1		
气候类别/阻燃等级 Climatic category/Passive Flammability Class	40/110/56/B		
工作温度范围 Operation Temperature Range	-40°C~110°C		
额定电压 Rated Voltage	300Vac/440Vac		
电容量范围 Capacitance Range	0.001μF~4.7μF		
电容量偏差Capacitance Tolerance	±5%(J)、±10%(K)、±20%(M) (20°C, 1kHz)		
耐电压 Voltage Proof	引线之间Between Terminals	4.3U <sub>R</sub> (VDC) , 60s	
	极壳之间Between Terminals to case	2380Vac, 60s	
绝缘电阻Insulation Resistance	C <sub>R</sub> ≤0.33μF, R≥15000 MΩ C <sub>R</sub> >0.33μF, RC≥5000S (20°C, 100V, 1min)		
损耗角正切Dissipation Factor	C<0.47μF	tgδ≤0.0015(1kHz)	tgδ≤0.0020(10kHz)
	0.47μF≤C≤1.0μF	tgδ≤0.0020(1kHz)	tgδ≤0.0040(10kHz)
	1.0μF<C≤4.7μF	tgδ≤0.0030(1kHz)	/

**5、产品安全认证Safety Approval**

认证标志Certification Logo	认证证书号Certification No.	认证机构Certification Country
	CQC22001364708	中国China
	E528513	美国USA/加拿大Canada
	40056347	德国Germany (欧盟) Europe

**6、产品代码及编写说明: Part number code rules**

M	P	1	1	0	4	K	4	4	D	K	R	8	0	0
1	2	3	4	5	6	7	8	9	10	11	12	13	14	15
第1~3位Digit 1 to 3			电容器型号代码Series code				第4~6位Digit 4 to 6			标称电容量代码 Rated capacitance code				
MP1=MPX/MKP-X1						ABC=AB×10 <sup>C</sup> pF Example104=10×10 <sup>4</sup> pF=0.1μF								
第7位Digit 7		电容量偏差代码 Capacitance tolerance code				第8~9位Digit 8 to 9			额定电压代码 Rated voltage code					
J=±5%, K=±10%, M=±20%						30=300Vac, 44=440Vac,								
第10~11位Digit 10 to 11			外形尺寸代码Dimension code				第12位Digit 12			商标颜色Trademark color				
见外形尺寸对照表 (W*T*H) Shape size						R=灰壳, X=黄壳, F=橙色, T=黑色, H=红色								
第13位Digit 13		线径代码 Line diameter code				第14~15位Digit 14 to 15			附加码extracode					
5=0.5、6=0.6、8=0.8、1=1.0、2=1.2						内部识别码 Internal Recognition Code								

**7、品质保证 (产品出厂检查) 试验: Quality ensuring test (before shipment):**

检查项目 (每批) Inspection item (each batch)	技术要求	检查水平IL	接收质量限AQL
		GB 2828一次正常抽样方案	
外观检查 Appearance inspection	标志正确, 清晰可读, 无明显损伤, 针孔气泡, 引出线无严重损伤。Marking is correct, clearly readable, No obvious damage, pinhole bubbles, There was no serious damage to the lead.	II	1.0
外形尺寸 Dimensions	按本文件第3条Refer to item 3		
电容量 Capacitance	按本文件第4条Refer to item 4	II	0.25*
损耗角正切 Dissipation Factor			
耐电压 Dielectric strength			
绝缘电阻 Insulation resistance			
可焊性 Solder ability	按本文件第8.1条Refer to item 8.1	S-3	1.0

\*: 耐电压不允许失效Voltage proof failure is not allowed

**8、试验方法及性能试验 Test Method And Performance**

No.	项目 project	性能要求 Performance requirements	试验方法 (GB/T6346.14-2015) experiment method
8.1	可焊性 Solder ability	上锡面积90%以上 More than 90% of the tin area	方法1 method 1 焊料温度 Solder temperature: 245±5°C 浸渍时间 Immersion time: 2.0±0.5s
8.2	初始测量 Initial measurement	电容量 capacitance 损耗角正切 DF: $C_R \leq 1\mu F$ , Test frequency: 10kHz $C_R > 1\mu F$ , Test frequency: 1kHz	
	引出端强度 Terminal strength	外观无可见损伤 There shall be no visible damage	拉力试验 Ual: 拉力: 0.5< $\phi$ d≤0.8mm: 10N, d> 0.8mm: 20N 弯曲试验 Ub: 每个方向上进行二次弯曲 Tensile test Ual: Tension: 0.5< $\phi$ d≤0.8mm; 10N, d> 0.8mm: 20N Bend: test Ub: secondary bending in each direction
	耐焊接热 Resistance to solder heat		方法1A: 260±5°C, 5s method 1A 260±5°C, 5s
	最后测量 Final measurement	外观无可见损伤 There shall be no visible damage 电容量变化: $\Delta C/C \leq \pm 5\%$ Capacitance: $\Delta C/C \leq \pm 5\%$ (relative to the initial value)	
8.3	初始测量 Initial measurement	电容量 capacitance 损耗角正切 DF: $C_R \leq 1\mu F$ , Test frequency: 10kHz $C_R > 1\mu F$ , Test frequency: 1kHz	

NO.	项目 project	性能要求 Performance requirements	试验方法 (GB/T6346.14-2015) Test method
8.4	温度快速变化 Rapid temperature change	外观无可见损伤 There shall be no visible damage	$T_A = -40^{\circ}\text{C}$ , $T_B = +110^{\circ}\text{C}$ 5次循环, 持续时间: $t=30\text{min}$ 5 cycles, duration: $t=30\text{min}$
	振动vibration	外观无可见损伤 There shall be no visible damage	振幅0.75mm或加速度 $98\text{m/s}^2$ (取严酷度较小者), 频率10~500Hz三个方向, 每个方向2h, 共6h Amplitude 0.75mm or acceleration $98\text{m/s}^2$ (slightly less severe), frequency 10~500Hz three sides Direction, 2h in each direction, total 6h
	碰撞 Bump		4000次, 加速度 $400\text{ m/s}^2$ , 脉冲持续时间: 6ms 4000 times, acceleration $400\text{ m/s}^2$ , Pulse duration: 6ms
	最后测量 Final measurement	外观无可见损伤 There shall be no visible damage 电容量: $\Delta C/C \leq \pm 5\%$ Capacitance: $\Delta C/C \leq \pm 5\%$ (relative to the initial value) 损耗角正切: 符合本文件第4条要求DF: Comply the Item 4	
8.5	气候顺序 climate seunce	初始测量 Initial measurement	按8.2或8.3的最终测量 Refer to item 8.2 and 8.3 final measurement
		干热Dry heat	+110°C, 16h
		循环湿热 Damp heat, Cyclic	试验Db,严酷度b, 第一次循环 Test Db, severity b, First cycle
		寒冷cold	-40°C, 2h
		循环湿热 Damp heat, Cyclic	试验Db,严酷度b, 剩余循环 Test Db, severity b, the other cycles,
		外观无可见损伤, 标志清晰, 电容量变化: $\Delta C/C \leq 5\%$ , 损耗角正切增加: $C_R \leq 1\mu\text{F} \leq 0.008$ (10kHz) $C_R > 1\mu\text{F} \leq 0.005$ (1kHz) 耐电压: 无击穿或飞弧 绝缘电阻 IR: $\geq$ 额定值的50% There shall be no visible damage, legible marking $\Delta C/C \leq 5\%$ (relative to the initial value) Increase of $\text{tg}\delta$ : $C_R \leq 1\mu\text{F} \Delta \text{tg}\delta \leq 0.008$ (10kHz) $C_R > 1\mu\text{F} \Delta \text{tg}\delta \leq 0.005$ (1kHz) Voltage proof: no breakdown and flashover I.R.: $\geq 50\%$ of the rated value	

NO.	项目 project	性能要求 Performance requirements	试验方法 (GB/T6346.14-2015) Test method
8.6	稳态湿热 Damp heat steady state	外观无可见损伤, 标志清晰, 电容量变化: $\Delta C/C \leq 5\%$ , 损耗角正切增加: $C_R \leq 1\mu F \leq 0.008$ (10kHz) $C_R > 1\mu F \leq 0.005$ (1kHz) 耐电压: 无击穿或飞弧 绝缘电阻 IR: $\geq$ 额定值的50% There shall be no visible damage, legible marking $\Delta C/C \leq 5\%$ (relative to the initial value) Increase of $\text{tg}\delta$ : $C_R \leq 1\mu F \Delta \text{tg}\delta \leq 0.008$ (10kHz) $C_R > 1\mu F \Delta \text{tg}\delta \leq 0.005$ (1kHz) Voltage proof: no breakdown and flashover IR: $\geq 50\%$ of the rated value	温度: $40 \pm 2^\circ\text{C}$ 湿度: $93 (+2/-3) \% \text{RH}$ 持续时间: 56天 Temperature: $40 \pm 2^\circ\text{C}$ Humidity: $93 (+2/-3) \% \text{rh}$ Duration: 56 days
8.7	脉冲电压 Pulse Voltage	用监视器监视, 有三次或更多次 脉冲波形表示电容器未发生自愈性击穿 3 times or more pluse waves indicate that the capacitor's self-healing breakdown doesn't occur	每个电容器施加24次相同极性的脉冲, 脉冲间隔时间不少于10S, 脉冲电压峰值 $C_R \leq 1\mu F, 4.0\text{kV}$ , $C_R > 1\mu F, 4.0/\sqrt{C_R} \text{KV}$ Ech capacitor is applied with same polarity pulse for 24 times. the interval between successive discharges shall be more than 10sec. Peak value of pulse voltage is $C_R \leq 1\mu F, 4.0\text{kV}$ , $C_R > 1\mu F, 4.0/\sqrt{C_R} \text{KV}$
8.8	耐久性 Endurance	外观无可见损伤, 标志清晰, 电容量变化: $\Delta C/C \leq 10\%$ , 损耗角正切增加: $C_R \leq 1\mu F \leq 0.008$ (10kHz) $C_R > 1\mu F \leq 0.005$ (1kHz) 耐电压: 无击穿或飞弧 绝缘电阻 IR: $\geq$ 额定值的50% There shall be no visible damage, legible marking $\Delta C/C \leq 10\%$ (relative to the initial value) Increase of $\text{tg}\delta$ : $C_R \leq 1\mu F \Delta \text{tg}\delta \leq 0.008$ (10kHz) $C_R > 1\mu F \Delta \text{tg}\delta \leq 0.005$ (1kHz) Voltage proof: no breakdown and flashover IR.: $\geq 50\%$ of the rated value	$+110^\circ\text{C}, 1000\text{h}$ 施加电压: 1.25倍额定电压 (50Hz), 每隔1h将电压升到1000V, 持续时间0.1S $+110^\circ\text{C}, 1000\text{h}$ Applied voltage: 1.25 times rated voltage(50Hz), 1h intervals zhe voltage to rise to 1000V ,duration 0.1S

NO.	项目 project	性能要求 Performance requirements	试验方法 (GB/T6346.14-2015) Test method												
8.9	充电和放电 Charging and discharging	电容量变化: $\Delta C/C \leq 10\%$ , 损耗角正切增加: $C_R \leq 1\mu F \leq 0.008$ (10kHz) $C_R > 1\mu F \leq 0.005$ (1kHz) 绝缘电阻 IR: $\geq$ 额定值的50% $\Delta C/C \leq 10\%$ (relative to the initial value) Increase of $\text{tg}\delta$ : $C_R \leq 1\mu F \Delta \text{tg}\delta \leq 0.008$ (10kHz) $C_R > 1\mu F \Delta \text{tg}\delta \leq 0.005$ (1kHz) IR.: $\geq 50\%$ of the rated value	次数: 10000次 充电持续时间: 0.5S, 放电持续时间: 0.5S 充电电压为 $\sqrt{2} U_R$ (dc) 充电电阻: $220/C_R$ ( $\Omega$ ) 或 $20\Omega$ (取较大者) $C_R$ 为标称电容量 ( $\mu F$ ) Number of times: 10,000 times Charging duration: 0.5s, discharge duration: 0.5s Charging voltage is rated voltage Charging resistance: $220/C_R(\Omega)$ or $20\Omega$ (whichever is greater) $C_R$ is the rated capacitance ( $\mu F$ )												
8.10	阻燃性试验 Passive flammability	离开火焰后, 最大燃烧时间不超过10s, 电容器燃烧的滴落物不应引燃在其下铺设的棉纸 The flaming time of each capacitor shall not go beyond 10s after it is taken apart from the flame. The drop objects of the capacitor shall not burn cotton paper after leaving flame	针焰试验, 阻燃等级B,在火焰上暴露一次 Needle flame test: burning resisting type B,exposed one time on flame <table border="1" style="margin-left: 20px;"> <tr> <th colspan="4">针对电容器体积V (mm<sup>3</sup>) 施加火焰时间 (s)</th> </tr> <tr> <td><math>\leq 250</math></td> <td><math>250 &lt; V \leq 500</math></td> <td><math>500 &lt; V \leq 1750</math></td> <td><math>&gt; 1750</math></td> </tr> <tr> <td>10</td> <td>20</td> <td>30</td> <td>60</td> </tr> </table>	针对电容器体积V (mm <sup>3</sup> ) 施加火焰时间 (s)				$\leq 250$	$250 < V \leq 500$	$500 < V \leq 1750$	$> 1750$	10	20	30	60
针对电容器体积V (mm <sup>3</sup> ) 施加火焰时间 (s)															
$\leq 250$	$250 < V \leq 500$	$500 < V \leq 1750$	$> 1750$												
10	20	30	60												
8.11	自燃性试验 Active flammability	纱布不燃烧 The gauze shall not burn	样品用未处理过的纯棉布缠绕至少一层,但不能多于两层, 每一样品应能承受贮能电容器放电20次; 每两次放电之间的间隔应为5s。 $U_i = 4.0kV \quad U \sim = U_R$ The specimens shall be individually wrapped in at least 1, but not more than 2, complete layers of cheesecloth, the cheesecloth shall be untreated pure cotton. Each sample shall be subjected to 20 discharged, the interval between successive discharges shall be 5s. $U \sim = U_R \quad U_i = 4.0kV$												

### 9、波峰焊接 (最大焊接温度) Peak Welding (Maximum Welding Temperature)

9.1焊接条件请按照右侧的焊接图表: Welding conditions should follow the welding chart on the right side:

	最高温度Tmax	时间Time
预热	最高温度 $\leq 130^\circ C$	$\leq 1\text{min}$
焊接锡炉温度	$260 \pm 5^\circ C$	$5 \pm 1\text{s}$

9.2如需焊接两次, 第二次焊接必须等到电容器恢复到常温。

If twice welding is required, the second welding must wait until the capacitor is restored to room temperature.

9.3插件产品仅适合使用波峰焊接 Plug-in products are only suitable for wave soldering

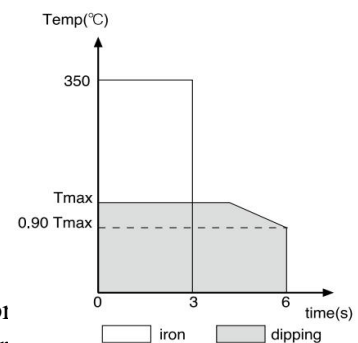

### 10、包装及运输要求 Packaging and transportation requirements

电容器以纸箱包装, 应避免雨雪的直接淋浇和机械损伤, 并保存在  $-10^\circ C \sim +40^\circ C$  温度下, 相对湿度75%以下, 应避免温度剧烈变化, 阳光直射和腐蚀性气体, 存放期不超出2年。 Capacitors are packaged in Corrugated box, should be stored at temperatures ranging from  $-10$  to  $+40^\circ C$ , with relative humidity below 75%, drastic temperature changes, direct sunlight and corrosive gases should be avoided. Storage period should not exceed In 2 years