

# MSKSEMI 美森科

SEMICONDUCTOR



ESD



TVS



TSS



MOV



GDT



PLED

## MC34063

---

### 产品规格手册

## 概述

MC34063 为一单片 DC-DC 变换集成电路，内含温度补偿的参考电压源 (1.25V)、比较器、能有效限制电流及控制工作周期的振荡器，驱动器及大电流输出开关管等，外配少量元件，就能组成升压、降压及电压反转型 DC-DC 变换器。该电路采用 DIP8 和 SOP8 封装形式

## 主要特点

- 工作电压范围宽 3.0V~40V
- 静态电流小
- 管脚排列图
- 具有输出电流限制功能,输出电流保护功能
- 输出开关极限电流达 1.3A
- 输出电压可调
- 工作频率可达 100kHz
- 内部基准参考电压精度 2%

## 参考信息

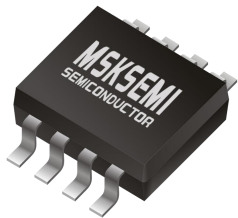
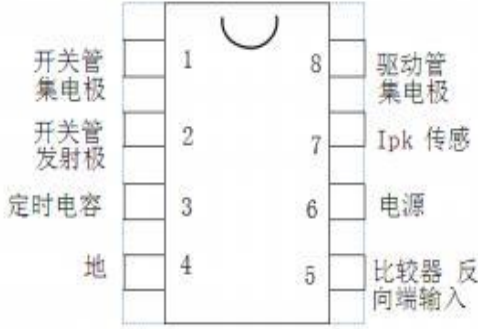
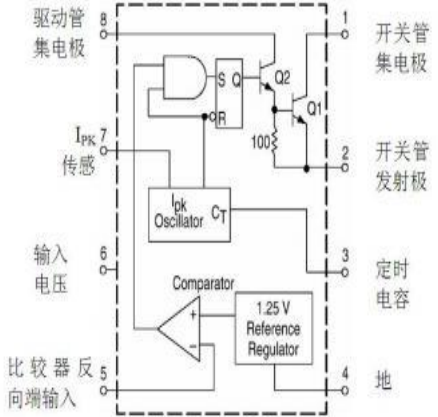
封装图	引脚排列	功能框架
	 <p>开关管集电极 1 8 驱动管集电极</p> <p>开关管发射极 2 7 I<sub>pk</sub> 传感</p> <p>定时电容 3 6 电源</p> <p>地 4 5 比较器反向端输入</p>	 <p>驱动管集电极 8 1 开关管集电极</p> <p>I<sub>pk</sub> 传感 7 2 开关管发射极</p> <p>输入电压 6 3 定时电容</p> <p>比较器反向端输入 5 4 地</p>
SOP-8		

## 引出端功能说明

引出端序号	功 能	符号	引出端序号	功 能	符号
1	开关管集电极	SC	5	比较器反向端输入	FB
2	开关管发射极	SE	6	输入电压	VCC
3	定 时 电 容	CT	7	检 测	lpk
4	地	GND	8	驱动管集电极	DC

## 极限值

参数名称	符 号	数 值		单 位
		最小	最大	
电源电压	Vcc		40	V
比较器输入电压范围	VIR	-0.3	40	V
输出管集电极电压	Vc(switch)		40	V
输出管发射极电压(VPIN1=32V)	VE(switch)		40	V
输出管集电极与发射极间的电压	VCE(switch)		40	V
驱动管集电极电压	Vc(driver)		40	V
驱动管集电极电流	Ic(driver)		100	mA
输出电流	ISW		1.3	A
功耗	PD		1.25	W
工作环境温度	TA	0	+70	°C
贮存温度	Tstg	-65	+150	°C

(Vcc=5.0V;TA=0°C~70°C,除非另外规定)

特性条件	符号	规范值			单位
		最小	典型	最大	
振荡器部分					
振荡频率(VPIN5=0V,CT=1.0F,TA=25°C)	fosc	24	33	42	KHz
充电电流(VCC=5.0V~32V,TA=25°C)	Ichg	24	33	42	uA
放电电流(VCC=5.0V~32V,TA=25°C)	Idischg	140	200	260	uA
放电与充电电流之比(VPIN7=VCC,TA=25°C)	Idischg/Ichg	5.2	6.2	7.5	--
电流限制器电压灵敏度(Ichg=Idischg,TA=25°C)	VIPK	250	300	350	mV
输出部分:					
饱和压降(ISW=1.0A,PIN1,8 连接)	VCE(sat)	--	1.0	1.3	V
饱和压降(ISW=1.0A,RPIN8=82 到 VCC)	VCE(sat)	--	0.45	0.7	V
直流放大倍数(ISW=1A,VCE=5V,TA=25°C)	hfe	50	120	--	--
集电极漏电流(VCE=30V)	IC(off)	--	0.01	100	uA
比较器部分:					
阈值电压(TA=25°C) (TA=0~70°C)	Vth	1.23 1.21	1.25 ..	1.27 1.29	V
输入偏置电流(VIN=0V)	IIB	--	-40	-400	nA
阈值电压线性调整率(VCC=3.0~30V)	Regline	--	1.4	5.0	mV
整体部分:					
电源电流 (VCC=5.0V~30V,CT=1.0nF, VPIN7=Vcc,VPIN5>Vth ,VPIN2=GND,其余悬空)	ICC	.....	2.5	4.0	mA

## 应用电路图

MC34063 作反转式 DC-DC 变换器

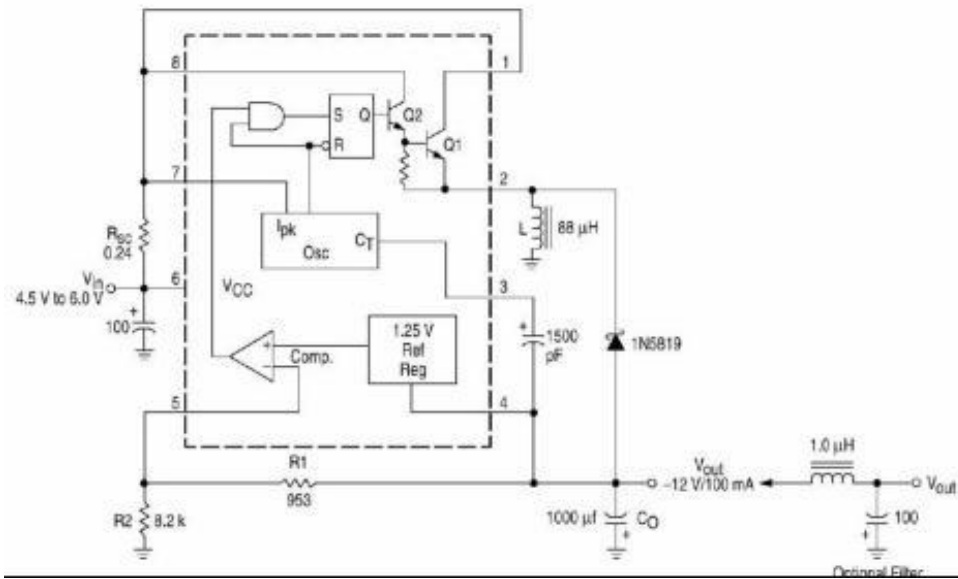

如图所示，当加接 LC 滤波器后，能进一步减小电压纹波及噪声，特性见下表

参数	测试条件	结果
线性调整率	$V_{IN}=4.5\sim 6.0V, I_o=100mA$	$3.0mV=0.012\%$
负载调整率	$V_{IN}=5.0V, I_o=10\sim 100mA$	$0.022V=+0.09\%$
输出纹波	$V_{IN}=5.0V, I_o=100mA$	500 mVpp
电路限制电流	$V_{IN}=5.0V, R_L=0.1$	910 mA
效率	$V_{IN}=5.0V, I_o=100mA$	64.5%
输出纹波	$V_{IN}=5.0V, I_o=100mA$	70 mVpp

特性曲线

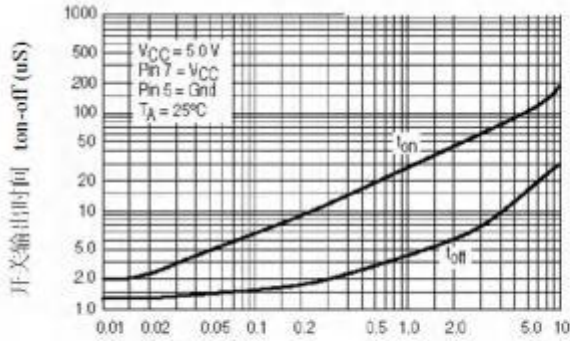

振荡器定时电容开关特性曲线

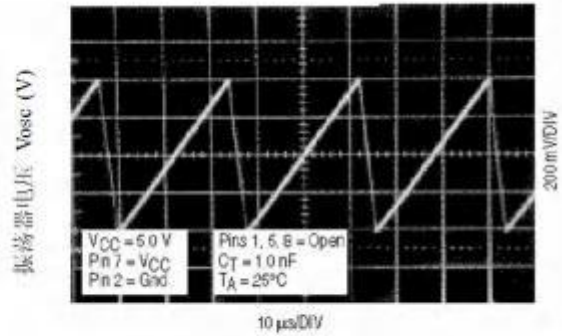

振荡器定时电容波形

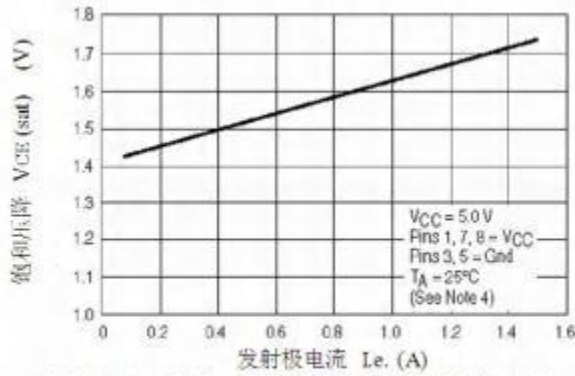

发射极输出饱和压降—发射极电流特性曲线

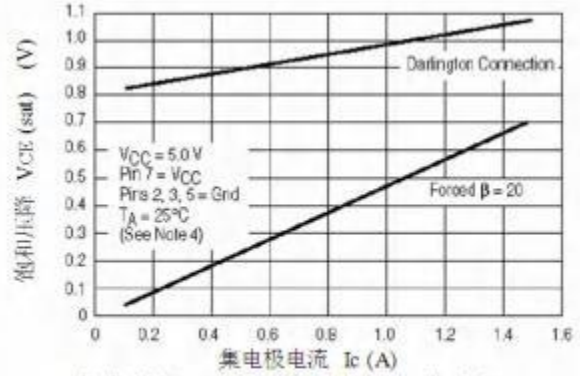

共发射极开关输出饱和压降—集电极电流特性曲线

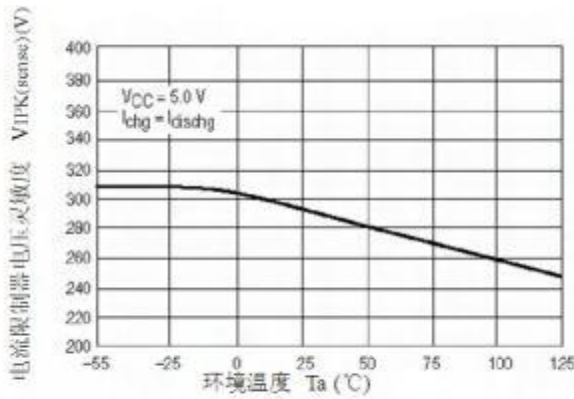

电流限制器电压灵敏度—温度特性曲线

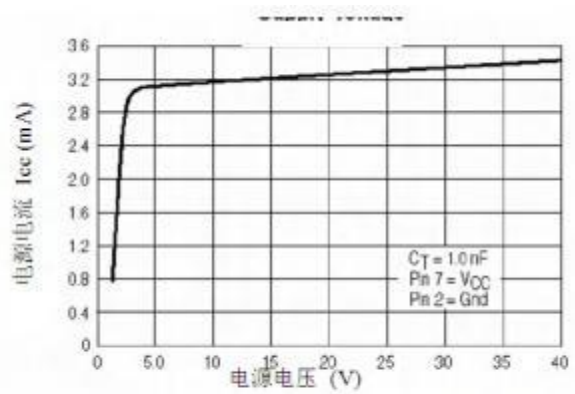

静态工作电流—工作电压特性曲线

包装数据

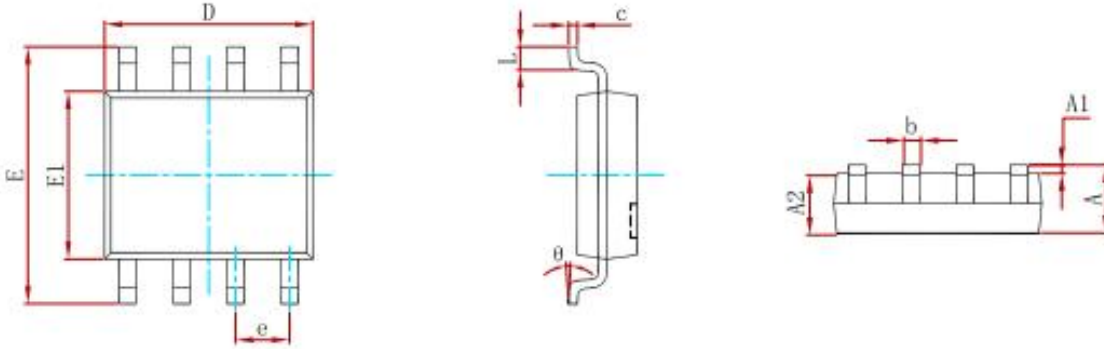

Symbol	Dimensions In Millimeters		Dimensions In Inches	
	Min	Max	Min	Max
A	1.350	1.750	0.053	0.069
A1	0.100	0.250	0.004	0.010
A2	1.350	1.550	0.053	0.061
b	0.330	0.510	0.013	0.020
c	0.170	0.250	0.007	0.010
D	4.800	5.000	0.189	0.197
e	1.270 (BSC)		0.050 (BSC)	
E	5.800	6.200	0.228	0.244
E1	3.800	4.000	0.150	0.157
L	0.400	1.270	0.016	0.050
θ	0°	8°	0°	8°

参考焊盘布局

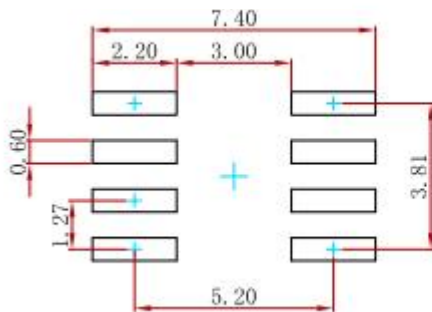

Note:  
 1. Controlling dimension: in millimeters.  
 2. General tolerance  $\pm 0.05\text{mm}$ .  
 3. The pad layout is for reference purposes only.

卷轴规格

P/N	PKG	QTY
MC34063	SOP-8	2500

## Attention

- Any and all MSKSEMI Semiconductor products described or contained herein do not have specifications that can handle applications that require extremely high levels of reliability, such as life-support systems, aircraft's control systems, or other applications whose failure can be reasonably expected to result in serious physical and/or material damage. Consult with your MSKSEMI Semiconductor representative nearest you before using any MSKSEMI Semiconductor products described or contained herein in such applications.
- MSKSEMI Semiconductor assumes no responsibility for equipment failures that result from using products at values that exceed, even momentarily, rated values (such as maximum ratings, operating condition ranges, or other parameters) listed in products specifications of any and all MSKSEMI Semiconductor products described or contained herein.
- Specifications of any and all MSKSEMI Semiconductor products described or contained herein stipulate the performance, characteristics, and functions of the described products in the independent state, and are not guarantees of the performance, characteristics, and functions of the described products as mounted in the customer's products or equipment. To verify symptoms and states that cannot be evaluated in an independent device, the customer should always evaluate and test devices mounted in the customer's products or equipment.
- MSKSEMI Semiconductor strives to supply high-quality high-reliability products. However, any and all semiconductor products fail with some probability. It is possible that these probabilistic failures could give rise to accidents or events that could endanger human lives, that could give rise to smoke or fire, or that could cause damage to other property. When designing equipment, adopt safety measures so that these kinds of accidents or events cannot occur. Such measures include but are not limited to protective circuits and error prevention circuits for safe design, redundant design, and structural design.
- In the event that any or all MSKSEMI Semiconductor products (including technical data, services) described or contained herein are controlled under any of applicable local export control laws and regulations, such products must not be exported without obtaining the export license from the authorities concerned in accordance with the above law.
- No part of this publication may be reproduced or transmitted in any form or by any means, electronic or mechanical, including photocopying and recording, or any information storage or retrieval system, or otherwise, without the prior written permission of MSKSEMI Semiconductor.
- Information (including circuit diagrams and circuit parameters) herein is for example only; it is not guaranteed for volume production. MSKSEMI Semiconductor believes information herein is accurate and reliable, but no guarantees are made or implied regarding its use or any infringements of intellectual property rights or other rights of third parties.
- Any and all information described or contained herein are subject to change without notice due to product/technology improvement, etc. When designing equipment, refer to the "Delivery Specification" for the MSKSEMI Semiconductor product that you intend to use.