

REVISION		RECORD	
REV.	CONTENT	MOD.	DATE
△	新发行		

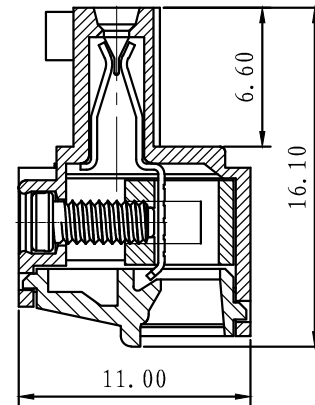
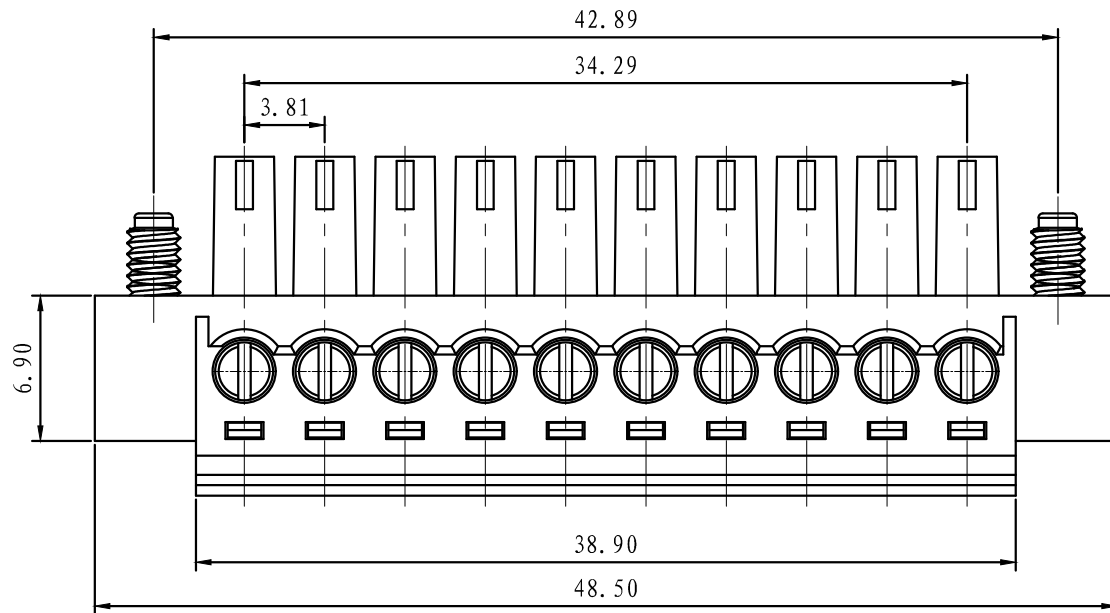
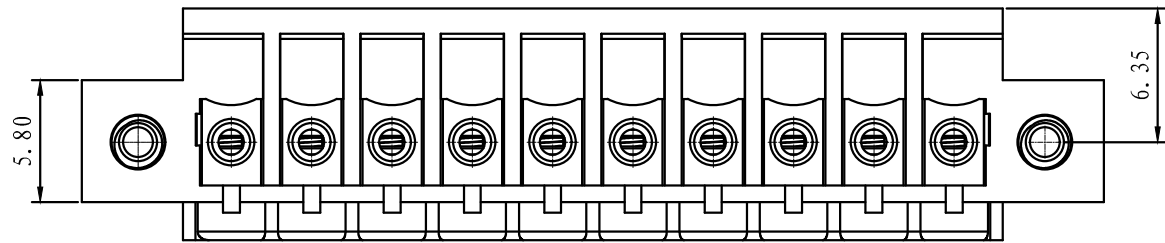

NOTES:

- | | |
|---|-------------------------|
| 1. Voltage Rating: 300V, Current Rating: 8A | 1. 额定电压: 300V, 额定电流: 8A |
| 2. PITCH: 3.81mm | 2. 间距: 3.81mm |
| 3. Insulation Withstands Voltage: AC2500V/min | 3. 耐压值: AC 2500V/min |
| 4. Using Temperature Range: -40° C - +105° C | 4. 使用条件: -40° - +105° |
| 5. Suitable Electric Wire: 28-16AWG | 5. 适用线规: 28-16AWG |
| 6. Screw Torque Value: 0.2Nm | 6. 螺丝扭力: 0.2Nm |

技术要求:

	pitch dimension			Nominal dimension					— □ ○
	over 0 to 6	over 6 to 10	over 10 to 24	over 0 to 30	over 30 to 60	over 60 to 100	over 100 to 150		
variable range	0 to 6	6 to 10	10 to 24	0 to 30	30 to 60	60 to 100	100 to 150	□	
Tolerance	±0.1	±0.15	±0.25	±0.2	±0.3	±0.5	±0.7 ±1.0	○	

6	LC1-3.81-耳朵螺丝	SPOYA255301V	2	碳钢	三价铬钝化彩锌
5	LC1-3.81-螺丝	SPOYA204802V	P	碳钢	三价铬钝化彩锌
4	LC1-3.81-夹子	1002B0001AV	P	磷青铜	镀锡
3	LC1-3.81-铜方块	F1A0BLC3813V	P	黄铜	镀银
2	LC1-3.81-盖子	1002COYXXAV	1	PA66-V0	
1	LC1M-3.81-本体	1002MOYXXAV	1	PA66-V0	

NO.	NAME OF PART	NO. OF PART	Q'TY	MATERIAL	NOTES
DES.	ARKINE	DATE	2010/5/8	UNITS	mm
CHK.		DATE		SIZE	A4
APP.		DATE		SCALE	1:1

上海联捷电气有限公司
Shanghai Elinker Electric CO., LTD

TITLE

LC1M-3.81-10P-1Y-00A
LC1M-3.81-成品

THIRD ANGLE PROJECTION

SHEET

1 / 1

DWG NO. SP-2-1002001 REV: V0