

MPB19-XXXXE-XX-JQ

MATERIAL:
 BUSHING: Aluminum alloy.
 BASE: PBT(UL 94-V0) , PC(UL 94-V2)
 ACTUATOR: PC ; Aluminum alloy.
 INNER ASSEMBLY: POM/PA66.
 SPRING: Spring steel.
 SEALING: Silicone.
 O-Ring: Silicone.
 TERMINAL: Brass, Silver plated.
 HEX NUT: Nickel plated brass.
 RoHS

Body type

A0	Stainless (Natural)
B1	Brass (Mirror Chrome Plated)
B2	Brass (Nikel Plated)
C3	Al alloy (Black Anodized)

Button type

F	Flat
---	------

Contact Configuration

1	1NO 1NC
2	2NO 2NC

Operating type

0	Momentary
1	LOCK

LED color

0	Without LED
1	White
3	Red
5	Yellow
6	Green
7	Blue

LED voltage

0	Without LED
3	3V
6	6V
12	12V
24	24V
36	36V
110	110V
220	220V

Terminal shape

J	Solder Terminal
---	-----------------

Terminal plating

Q	Silver
R	Gold

Light type

0	Without LED
R	Ring (Fixed)
D	Spot
E	Ring (Moveable)

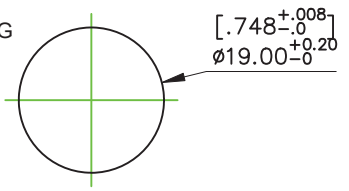
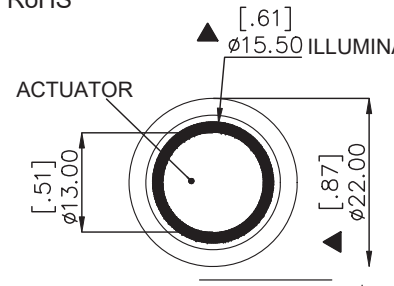

PANEL CUTOUT
 MAX.PANEL THICKNESS:10.0mm[.394]

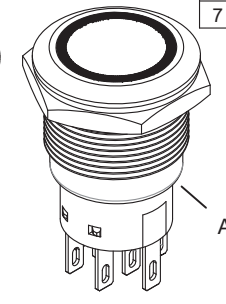
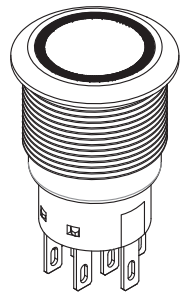
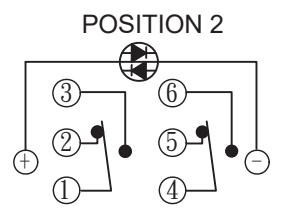
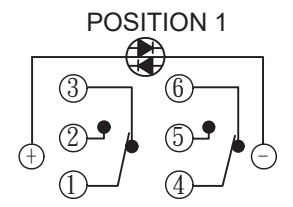

ASSEMBLED VIEW

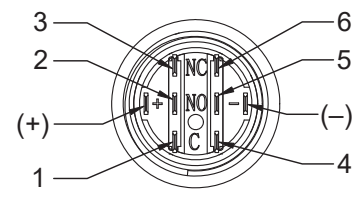
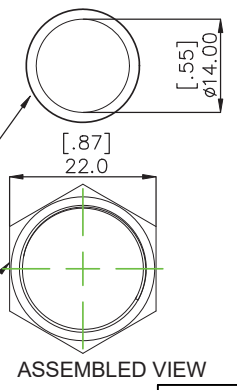
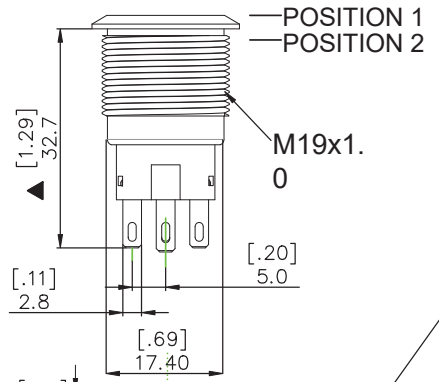
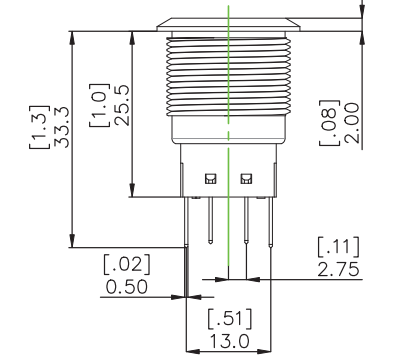

SPECIFICATIONS

- CONTACT MATERIAL: Brass, coin silver, silver plated.
- RATING: 1th 5A/250VAC. resistive load 3A/250VAC.
- ELECTRICAL LIFE: 50,000 MAKE-AND-BREAK CYCLES AT FULL LOAD.
- MECHANICAL LIFE: SELF-LOCK 500,000.
- INSULATION RESISTANCE: 1,000MΩ MIN AT 500VDC .
- DIELECTRIC STRENGTH: 2,000V RMS@sea level.
- CONTACT RESISTANCE: 50mΩ MAX.@1A 12VDC(initial value).
- OPERATING TEMPERATURE: -20°C to 55°C .
- TRAVEL: ABOUT 3.2mm.
- OPERATION PRESSURE: 1Pole 2.5±1N. / 2Pole 3.5±1N.
- INGRESS PROTECTION: IP67.
- TORQUE: 5~14Nm.



蘇州寰立電子有限公司
 HUANLI ELECTRONICS CO., LTD.

△				
△				
△				
△				
△				
SYM	DISCIPTION	DATE	APPROVED	

TOLERANCES UNLESS OTHERWISE SPECIFIED
 LINEAR: ±0.30 ANGULAR: ±3'

REVISIONS	SCALE
A	5/1

SIGNATURES		DATE	TITLE
DRAWN	Alvin	2024.3.25	METAL PUSHBUTTON SWITCH
CHK'D	Weiwei	2024.3.25	
APPV'D	Gavin	2024.3.25	

NO.	MPB19-C3F21E-10-JQ
-----	--------------------

HUANLI ELECTRONICS CO., LTD.

MPB19/22 SERIES SPECIFICATION	Document No	QW-1002	REV : B
	Page	Page 1 of 5	Pb

1. Style :

This specification describes “Metal Pushbutton Switch ” , mainly used as signal or double switch of electric devices, with the general requirements of mechanical and electrical characteristic.

①Switch combination : 1N01NC/2N02NC.

②Enclosure material : Stainless steel / Nickel plated brass/ Aluminum alloy.

③Operating Type : Resettable or Self-locking.

④Operating Temperature Range : -20 °C ~+55 °C.

Storage Temperature Range : -40°C ~+85 °C.

⑤Degrees of protection provided by enclosures

IP code: IP67.

IK code: IK08 .(For case :Nickel plated brass / Aluminum alloy)

IK10 .(for case :stainless steel)

2. Electrical Rating : I_{th} :5A / U_i :250VAC.

I_e: 3A / U_e :250VAC (resistive load).

I_e: 3A / U_e :28VDC (resistive load).

3. Type of Actuation : Pushbutton Switch.

4. Test Sequence :

	ITEM	DESCRIPTION	TEST CONDITIONS	REQUIREMENTS
APPEARANCE	1	Visual Examination	By Visual Examination check without and out pressure & testing.	There shall be no defects that affect the serviceability of the product.
ELECTRIC PERFORMANCE	2	Contact Resistance	To be measured between the two terminals associated with each switch pole.	50mΩ Max.
	3	Insulation Resistance	Measurements shall be made following application of 500 VDC / 100mA potential across terminals and cover for 1 minute.	1000MΩ min.
	4	Dielectric Withstanding Voltage	①2000VAC(50Hz or 60Hz) / between terminals /1minute. ②2000 VAC(50Hz or 60Hz) /between terminals and frame/ 1minute.	There shall be no breakdown or flashover.

HUANLI ELECTRONICS CO., LTD.

MPB19/22 SERIES SPECIFICATION	Document No	QW-1002	REV : B
	Page	Page 2 of 5	Pb

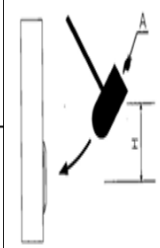
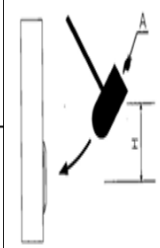
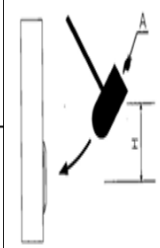
	ITEM	DESCRIPTION	TEST CONDITIONS	REQUIREMENTS													
MECHANICAL PERFORMANCE	5	Operation pressure	MODEL-1305N MECHANICAL TEST 500gram、1000gram、2000gram.	1Pole about 2.5 ± 1N. 2Pole about 3.5 ± 1N.													
	6	Operation Travel	Full Travel.	3.2 ± 0.3mm.													
	7	Torque	Applied to nut.	About 5~14Nm.													
	8	Panel Thickness	Applied to nut.	About 1~10mm.													
	9	IK Code	<table border="1" style="width: 100%; border-collapse: collapse; margin-bottom: 5px;"> <thead> <tr> <th style="font-size: 0.8em;">IK Degree</th> <th style="font-size: 0.8em;">Weight (A)</th> <th style="font-size: 0.8em;">Original Height (H)</th> <th style="font-size: 0.8em;">Impact Energy</th> <th style="font-size: 0.8em;">Impact Diagram</th> </tr> </thead> <tbody> <tr> <td style="text-align: center;">08</td> <td style="text-align: center;">1.25 kg</td> <td style="text-align: center;">40cm</td> <td style="text-align: center;">5J</td> <td rowspan="2" style="text-align: center;">  </td> </tr> <tr> <td style="text-align: center;">10</td> <td style="text-align: center;">5.0kg</td> <td style="text-align: center;">40cm</td> <td style="text-align: center;">20J</td> </tr> </tbody> </table>	IK Degree	Weight (A)	Original Height (H)	Impact Energy	Impact Diagram	08	1.25 kg	40cm	5J		10	5.0kg	40cm	20J
IK Degree	Weight (A)	Original Height (H)	Impact Energy	Impact Diagram													
08	1.25 kg	40cm	5J														
10	5.0kg	40cm	20J														
OPERATING LIFE	10	Operating Life	<p>Measurements shall be made following the test forth below :</p> <p>①Ie:3A /Ue:250VAC .(resistive load)</p> <p>②Rate of Operation: 6-8operation cycles per minute.</p> <p>③Electronics Life Test : 50,000 cycles. (for 3A/250VAC)</p> <p>④Electronics Life Test : 6,000 cycles. (for 3A/28VDC)</p> <hr/> <p>④Mechanical Life Test : Resettable : 1,000,000 cycles. Self-locking: 500,000 cycles.</p>	<p>①Dielectric Strength : between terminals :1000VAC. between terminals of opposite polarity :2000VAC.</p> <p>②Insulation Resistance : 1000MΩ (at 500VDC)min.</p> <p>③Contact Resistance : 100mΩ Max.</p>													

HUANLI ELECTRONICS CO., LTD.

MPB19/22 SERIES SPECIFICATION	Document No	QW-1002	REV : B
	Page	Page 3 of 5	Pb

	ITEM	DESCRIPTION	TEST CONDITIONS	REQUIREMENTS
HUMIDITY RESISTANCE	11	Resistance Low Temperature	Following the test set forth below the sample shall be left in normal temperature and humidity conditions for 1 hour before the measurements are made: ① Temperature : $-20\pm 3^{\circ}\text{C}$. ② Time : 96 hours.	As shown in item 2~4.
	12	Resistance High Temperature	Following the test set forth below the sample shall be left in normal temperature and humidity conditions for 1 hour before the measurements are made: ① Temperature : $55\pm 3^{\circ}\text{C}$. ② Time : 96 hours.	As shown in item 2~4.
	13	Resistance Humidity	Following the test set forth below the sample shall be left in normal temperature and humidity conditions for 1 hour before the measurements are made: ① Temperature: $40\pm 2^{\circ}\text{C}$ ② Relative Humidity: 90~95% ③ Time: 96 hours.	① Contact Resistance: 100 mΩ Max. ② Insulation Resistance: 1000MΩ min.

HUANLI ELECTRONICS CO., LTD.

MPB19/22 SERIES SPECIFICATION	Document No	QW-1002	REV : B
	Page	Page 4 of 5	Pb

	ITEM	DESCRIPTION	TEST CONDITIONS	REQUIREMENTS
HUMIDITY RESISTANCE	14	Salt spray Testing	Following the test set forth below the sample shall be left in normal temperature and humidity conditions for an hour before the measurements are made: ①Temperature:35±2℃. ②The ratio of salt-water : 5%. ③The spray amount of salt- water : 1~2 ml/h. ④Time:48 hours.	The testing standard based on bubble, crack, And magnifying glass with gauge.
	15	Test of IP 67	Protected against the effects of Temporary immersion in water. (1m below the surface of the water for a duration of 30 min).	IP67 According to EN 60529 : 1991 + A1 : 2000 IEC 60529 : 2001
ROHS	16	HSF	Refer RoHS Standard : The electronic electrical machinery product limits with six big chemical materials.	Cd : 100ppm Pb : 1000ppm Hg : 1000ppm Cr6+ : 1000ppm PBB 、 PBDE : 1000ppm
SOLDER HEAT RESISTANCE	17	Manual Soldering	■ hand Soldering : ①Soldering Temperature : 290℃.(Max) ②Duration of Solder Heated : 3 seconds (Max). ■ Precautions in Handling: ①Please make sure that there is no flux rose over the surface of the PCB.	①Shall be free from pronounced backlash and falling-off or breakage terminals. ②As shown in item 2~4.

Wiring:

1. Solder the terminals using a 60W soldering iron at 290℃ within 3 seconds. (Sn-Ag-Cu type solder is recommended.)
2. When soldering, be sure to keep the soldering iron as far away from the housing as possible.
3. Also ensure that no tensile force is applied to the terminal. Do not bend the terminal or apply excessive force to the terminal.

HUANLI ELECTRONICS CO., LTD.

MPB19/22 SERIES SPECIFICATION

Document No

QW-1002

REV : B

Page

Page 5 of 5



5. LED Specifications : (LED Without resistor)

Color	VF(v) Min.	VF(v) TYP.	VF(v) MAX.	IF(MAX)
White	2.8	3.3	3.8	20mA
Red	1.8	2.1	2.5	20mA
yellow	1.8	2.1	2.5	20mA
Blue	2.8	3.2	3.8	20mA
Green	2.8	3.2	3.6	20mA