

Jul.1.2024 Copyright 2024 HIROSE ELECTRIC CO., LTD. All Rights Reserved.  
 In case of consideration for using Automotive equipment / device which demand high reliability, kindly contact our sales window correspondents.

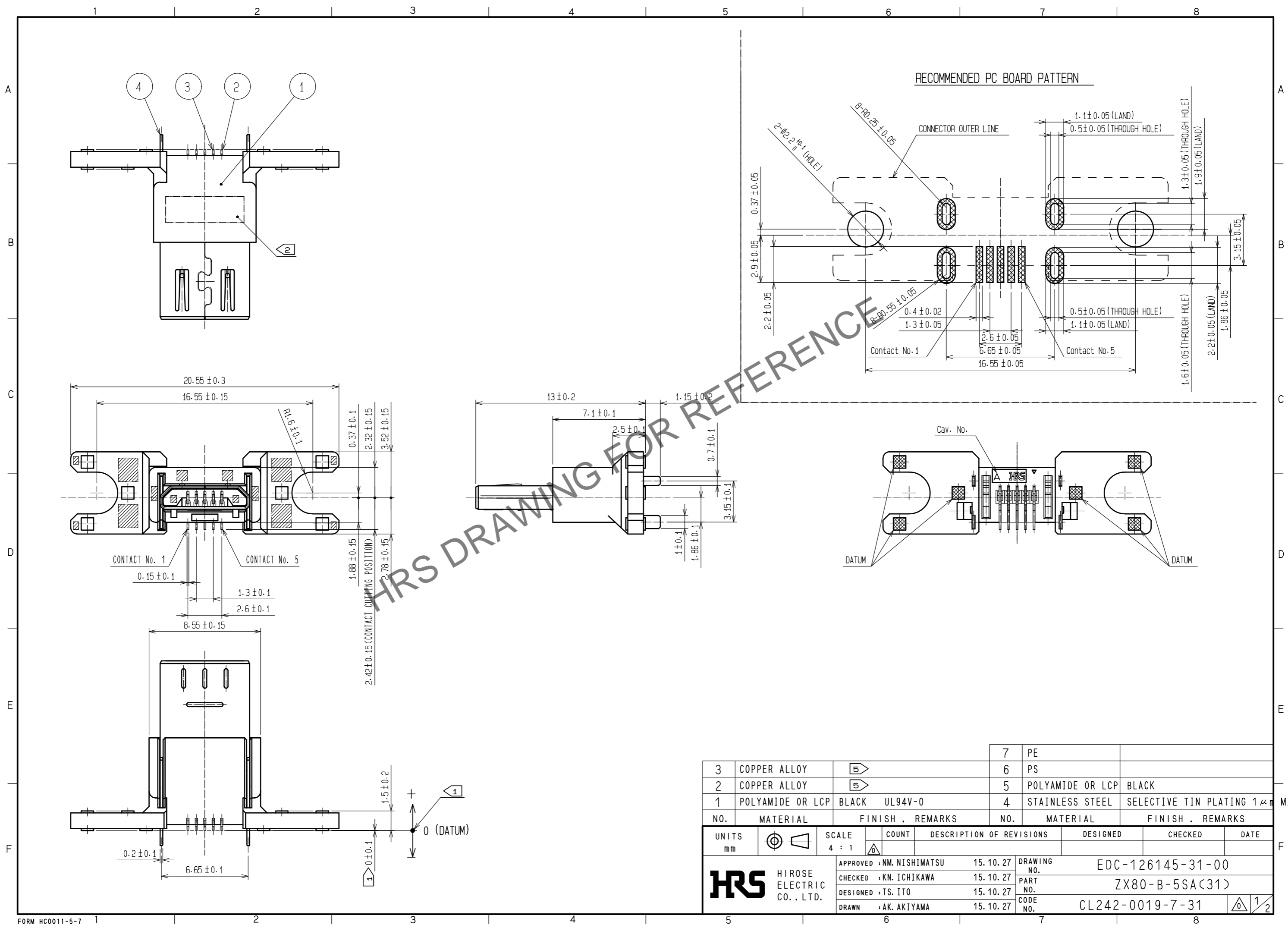

3	COPPER ALLOY	5	7	PE				
2	COPPER ALLOY	5	6	PS				
1	POLYAMIDE OR LCP	BLACK UL94V-0	5	POLYAMIDE OR LCP	BLACK			
			4	STAINLESS STEEL	SELECTIVE TIN PLATING 1 μm MIN.			
NO.	MATERIAL	FINISH . REMARKS	NO.	MATERIAL	FINISH . REMARKS			
UNITS	mm	SCALE	4 : 1	COUNT	DESCRIPTION OF REVISIONS	DESIGNED	CHECKED	DATE
<b>HRS</b> HIROSE ELECTRIC CO., LTD.		APPROVED	·NM. NISHIMATSU	15.10.27	DRAWING NO.	EDC-126145-31-00		
		CHECKED	·KN. ICHIKAWA	15.10.27	PART NO.	ZX80-B-5SA(31)		
		DESIGNED	·TS. ITO	15.10.27	CODE NO.	CL242-0019-7-31		
		DRAWN	·AK. AKIYAMA	15.10.27				1/2

Jul.1.2024 Copyright 2024 HIROSE ELECTRIC CO., LTD. All Rights Reserved.  
 In case of consideration for using Automotive equipment / device which demand high reliability, kindly contact our sales window correspondents.

3 DRAWING FOR PACKING(FREE)

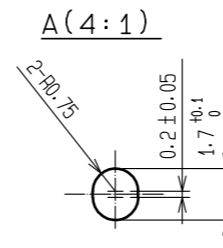
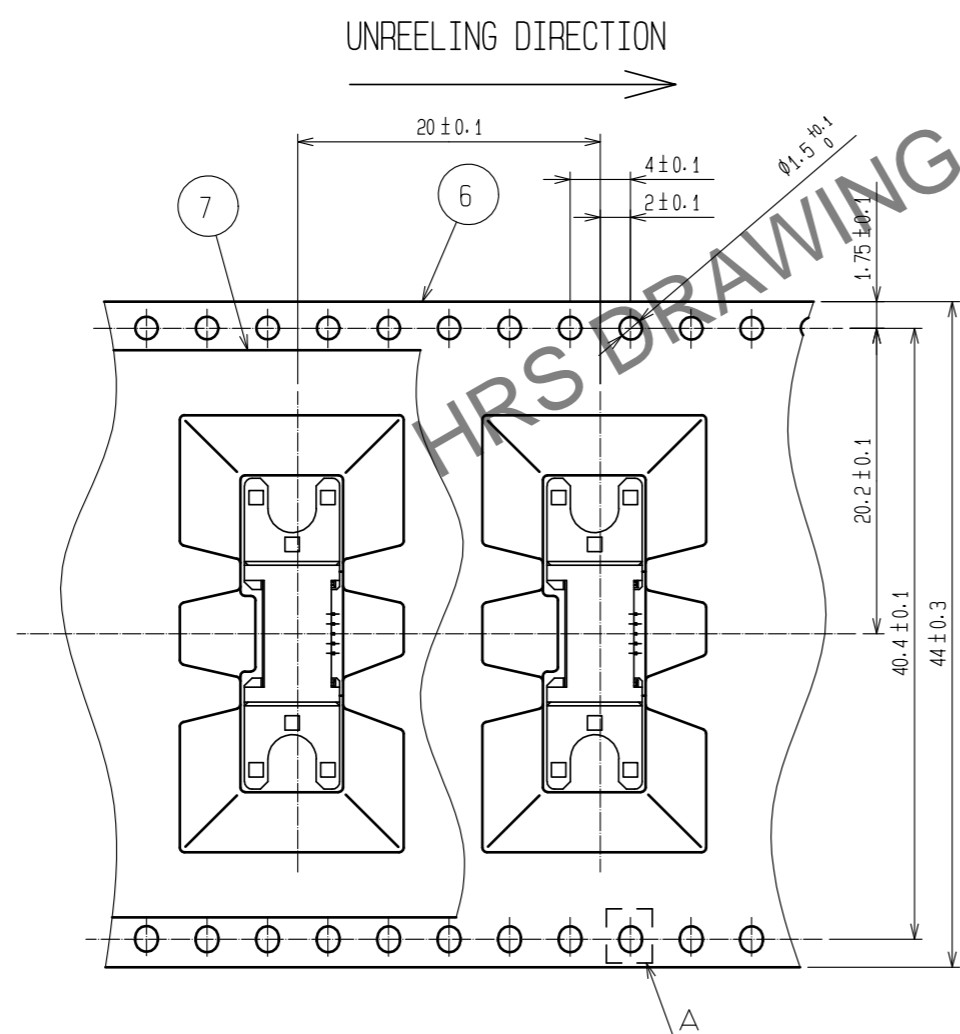
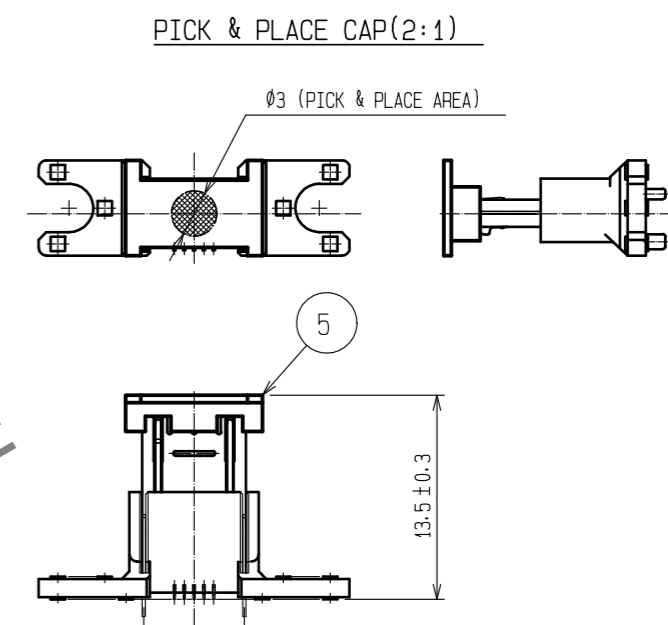
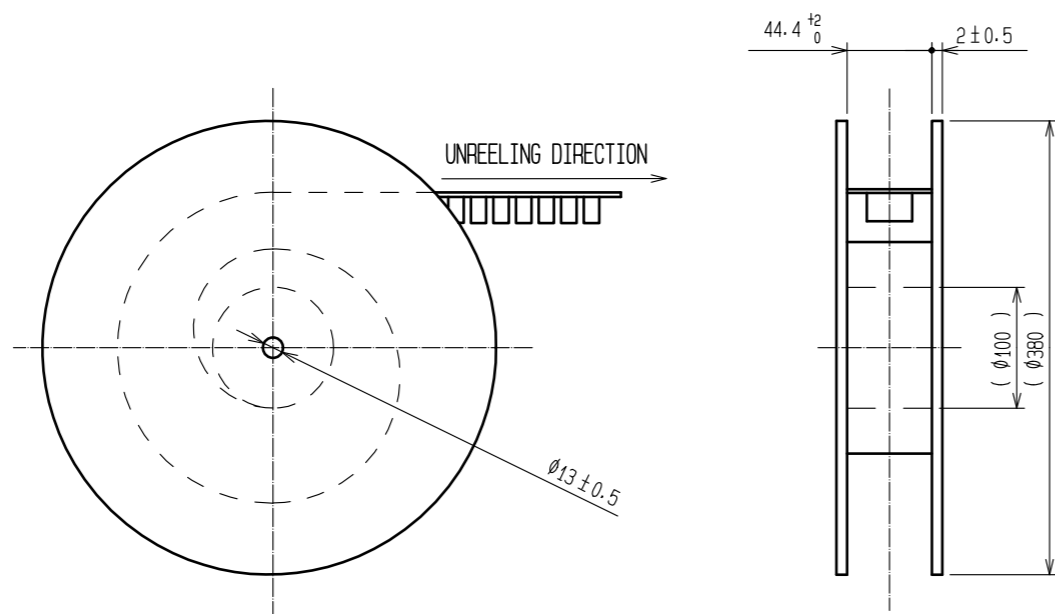

NOTES. 1 DIMENSIONS OF SMT RANGE AND CO-PLANARITY ARE AS SHOWN BELOW.

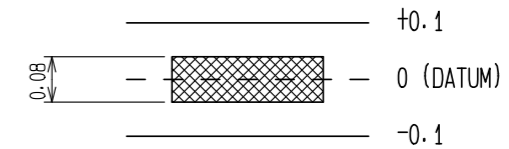

- 2 LOT No. SHALL BE INDICATED AT THE POSITION AS SHOWN.
- 3 PER REEL: 200 pcs.
- 4 THE SHADED AREAS SHOW LOCATIONS OF EJECTOR PINS.
- 5 PLATING  
 CONTACT AREA : GOLD 0.75μm MIN.  
 READ AREA : GOLD 0.03μm MIN.  
 UNDER PLATING: NICKEL 2μm MIN.

<b>HRS</b>	DRAWING NO.	EDC-126145-31-00
	PART NO.	ZX80-B-5SA(31)
	CODE NO.	CL242-0019-7-31