

# NA1-5

## Ultra-slim Body 25mm Beam Pitch Area Sensor

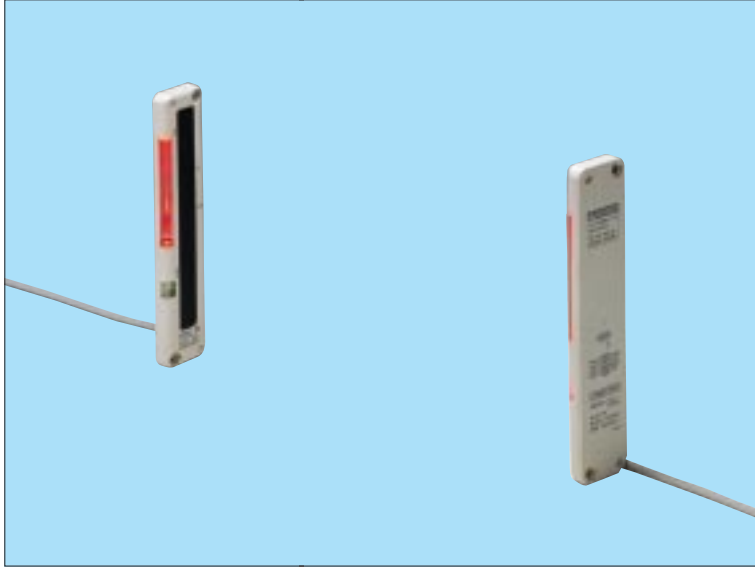

Even a Slim Hand Is Detected by the 25mm Pitch Beam Curtain

**CE Marked**  
Conforming to EMC Directive

### 10mm Thick: 1/2 of Conventional Model

It fits into a small space, without obstructing normal operation.

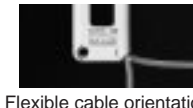

Flexible cable orientation

### Clearly Visible Job Indicator

Both the emitter and the receiver are incorporated with 55mm wide large job indicators. They can also be used as large size operation indicators if the job indicator input and the sensing output are connected together.

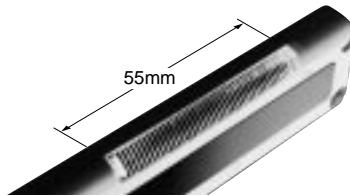

### Long Sensing Range: 3m

Its long sensing range of 3m is sufficient for confirming access to a parts shelf. Further, if the sensor has been set to the Light-ON mode, the output is turned OFF should the cable break.

### Parallel Installation

Setting different emission frequencies for two sensors prevents mutual interference. Use of two sensors together covers a wider detection area.

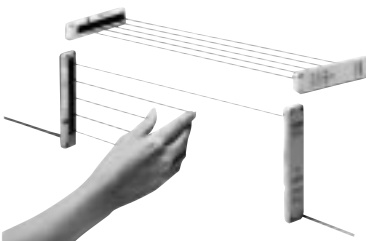

### Lighting Pattern Selectable

The job indicator operation can be selected as either continuous lighting or blinking.

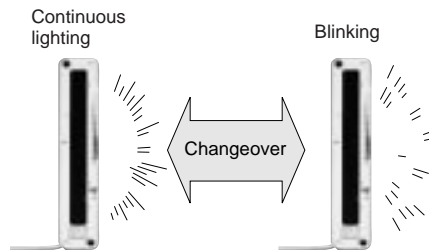

### Detection Operation Selectable

Detection on interruption of either minimum one beam or minimum two beams can be selected to suit the application.

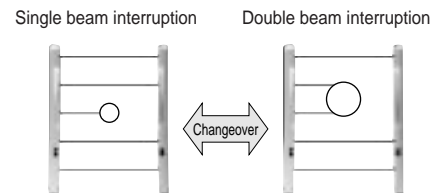

It can detect a  $\phi$  35mm or more opaque object at any place in the sensing area.

The sensor recognizes a larger object such as a hand, but ignores a small object. It is also useful if some obstacle normally interrupts one of the beams.



## APPLICATIONS

Preventing wrong parts picking

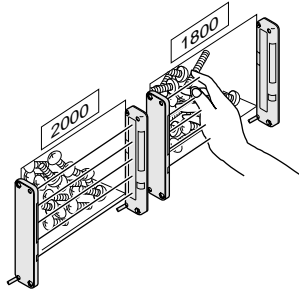

Access control on assembly line

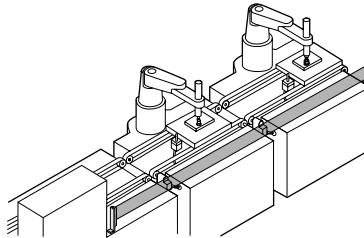

Detecting parts having wide positioning area

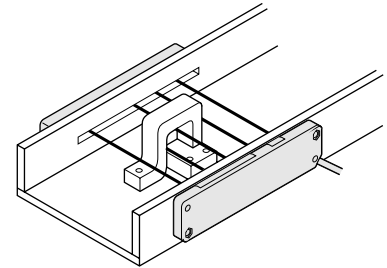

**WARNING** Never use this product in any personnel safety application.

## ORDER GUIDE

Appearance	Sensing range (Note)	Model No.	Output
		<b>NA1-5</b>	NPN open-collector transistor
		<b>NA1-5-PN</b>	PNP open-collector transistor

Note: The sensing range is the possible setting distance between the emitter and the receiver. The sensor can detect an object less than 0.2m (0.05m when set to SHORT) away.

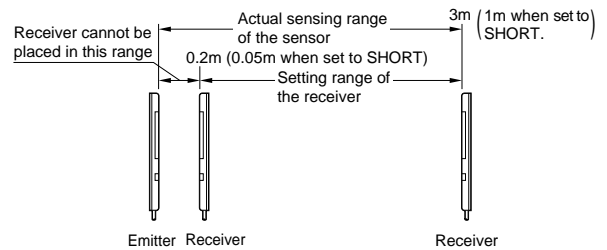

## OPTIONS

Designation	Model No.	Description
Sensor mounting bracket	<b>MS-NA1-1</b>	Four bracket set (Four M4 (length 15mm) screws with washers, eight nuts, four hooks, four spacers and eight M4 (length 18mm) screws with washers are attached. (Spacers are not attached with <b>MS-NA1-1</b> .)
	<b>MS-NA2-1</b>	
Sensor protection bracket	<b>MS-NA3</b>	It protects the sensor body. Two bracket set (Four M4 (length 15mm) screws with washers, and four nuts are attached.)
Slit mask	<b>OS-NA1-5</b>	The slit mask restrains the amount of beam emitted or received. (Seal type, 10 Nos. set)

### Sensor protection bracket

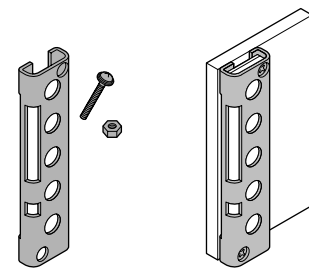

M4 screws with washers, and nuts are attached.

### Sensor mounting bracket

• **MS-NA1-1**

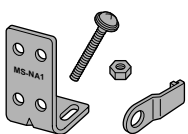

M4 screws with washers, nuts and hooks are attached.

• **MS-NA2-1**

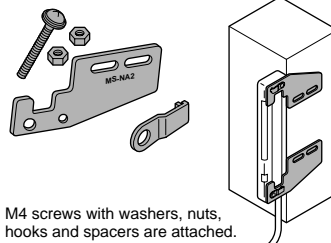

M4 screws with washers, nuts, hooks and spacers are attached.

### Slit mask

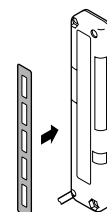

Since the slit mask is seal type, it can be used by sticking it to the detection surface. Take care that the sensing range will be reduced when the slit mask is used. Contact our office for details.



# NA1-5

## SPECIFICATIONS

Type		Area sensor	
		NPN output	PNP output
Item	Model No.	NA1-5	NA1-5-PN
Sensing height		100mm	
Sensing range (Note 1)		0.2 to 3m (0.05 to 1m when set to SHORT)	
Beam pitch		25mm	
Number of beam channels		5 beam channels	
Sensing object		φ 35mm or more opaque object	
Supply voltage		12 to 24V DC ± 10% Ripple P-P 10% or less	
Power consumption (Note 2)		Emitter: 0.5W or less, Receiver: 0.8W or less	Emitter: 0.6W or less, Receiver: 0.9W or less
Output		NPN open-collector transistor <ul style="list-style-type: none"> <li>• Maximum sink current: 100mA</li> <li>• Applied voltage: 30V DC or less (between output and 0V)</li> <li>• Residual voltage: 1V or less (at 100mA sink current) 0.4V or less (at 16mA sink current)</li> </ul>	PNP open-collector transistor <ul style="list-style-type: none"> <li>• Maximum source current: 100mA</li> <li>• Applied voltage: 30V DC or less (between output and + V)</li> <li>• Residual voltage: 1V or less (at 100mA source current) 0.4V or less (at 16mA source current)</li> </ul>
	Utilization category	DC-12 or DC-13	
	Output operation	ON or OFF when one or more beams are interrupted/ ON or OFF when two or more beams are interrupted, selectable by operation mode switch	
Short-circuit protection		Incorporated	
Response time		10ms or less (when the interference prevention is used, in Light state: 30ms or less, in Dark state: 13ms or less)	
Indicators	Emitter	Power indicator: Green LED (lights up when the power is ON) Job indicator: Orange LED (lights up or blinks when the job indicator input is Low, lighting pattern is selected by operation mode switch)	
	Receiver	Operation indicator: Red LED (lights up when one or more beams are interrupted, but lights up when two beams or more are interrupted in the double-beam-interruption mode) Stable incident beam indicator: Green LED (lights up when all beams are stably received) Job indicator: Orange LED (lights up or blinks when the job indicator input is Low, lighting pattern is selected by operation mode switch)	
Interference prevention function		Incorporated	
Environmental resistance	Pollution degree	3 (Industrial environment)	
	Protection	IP62 (IEC)	
	Ambient temperature	- 10 to + 55°C (No dew condensation or icing allowed), Storage: - 20 to + 70°C	
	Ambient humidity	35 to 85% RH, Storage: 35 to 85% RH	
	Ambient illuminance	Sunlight: 10,000 lx at the light-receiving face, Incandescent light: 3,000 lx at the light-receiving face	
	EMC	Emission: EN50081-2, Immunity: EN50082-2	
	Voltage withstandability	1,000V AC for one min. between all supply terminals connected together and enclosure	
	Insulation resistance	20MΩ, or more, with 250V DC megger between all supply terminals connected together and enclosure	
	Vibration resistance	10 to 150Hz frequency, 0.75mm amplitude in X, Y and Z directions for two hours each	
Shock resistance		490m/s <sup>2</sup> acceleration (50G approx.) in X, Y and Z directions for three times each	
Emitting element		Infrared LED (synchronized scanning system)	
Material		Enclosure: Heat-resistant ABS, Lens cover: Acrylic, Indicator cover: Acrylic	
Cable		0.3mm <sup>2</sup> 4-core (emitter: 3-core) oil resistant cable, 2m long	
Cable extension		Extension up to total 100m is possible for both emitter and receiver with 0.3mm <sup>2</sup> , or more, cable.	
Weight		Emitter: 70g approx., Receiver: 80g approx.	

Notes: 1) The sensing range is the possible setting distance between the emitter and the receiver. The sensor can detect an object less than 0.2m (0.05m when set to SHORT) away.

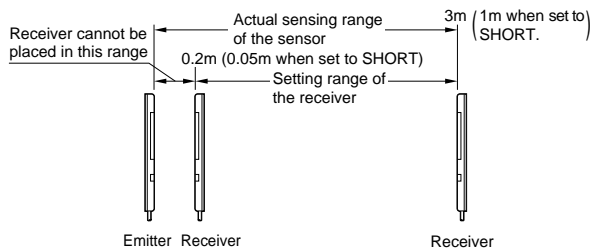

2) Obtain the current consumption by the following equation.  
 Current consumption = Power consumption ÷ Supply voltage  
 (e.g.) When the supply voltage is 12V, the current consumption of the emitter is: 0.5W ÷ 12V = 0.042A = 42mA.

## I/O CIRCUIT AND WIRING DIAGRAMS

### NA1-5 NPN output type

#### I/O circuit diagram

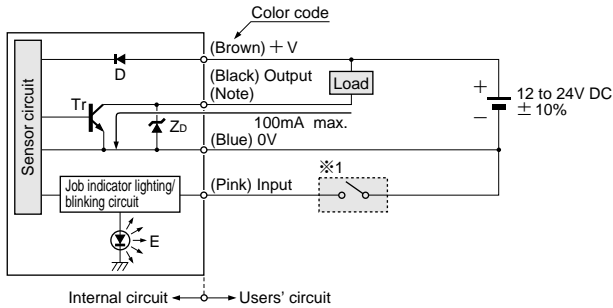

Note: The emitter is not incorporated with the output.

Symbols ... D: Reverse supply polarity protection diode  
Zd: Surge absorption zener diode  
Tr: NPN output transistor  
E: Job indicator

#### Wiring diagram

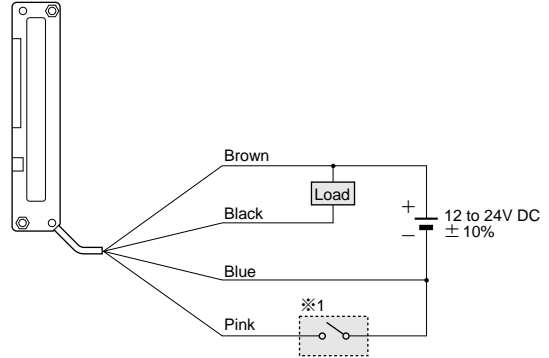

※1

Non-contact voltage or  
NPN open-collector transistor

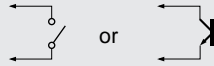

Low (0 to 2V): Lights up or Blinks  
High (5 to 30V, or open): Lights off

### NA1-5-PN PNP output type

#### I/O circuit diagram

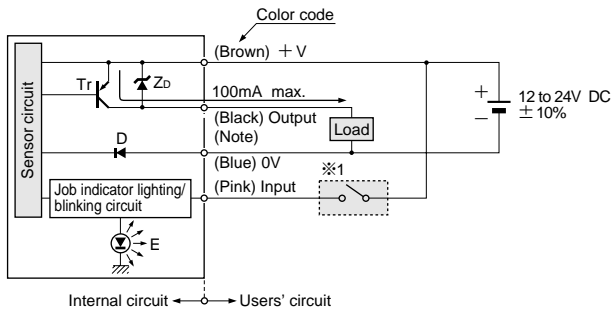

Note: The emitter is not incorporated with the output.

Symbols ... D: Reverse supply polarity protection diode  
Zd: Surge absorption zener diode  
Tr: PNP output transistor  
E: Job indicator

#### Wiring diagram

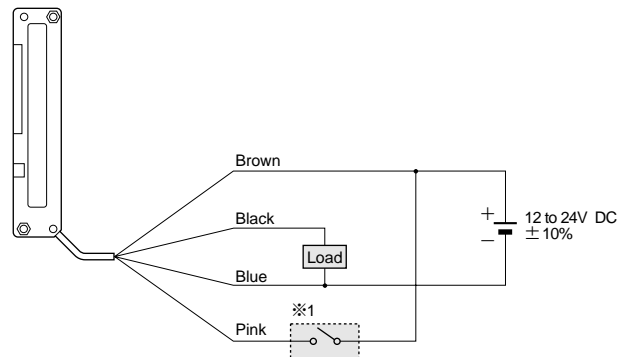

※1

Non-contact voltage or  
PNP open-collector transistor

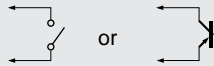

High (4V or more): Lights up or Blinks  
Low (0 to 0.6V, or open): Lights off

## SENSING CHARACTERISTICS (TYPICAL)

#### Correlation between setting distance and excess gain

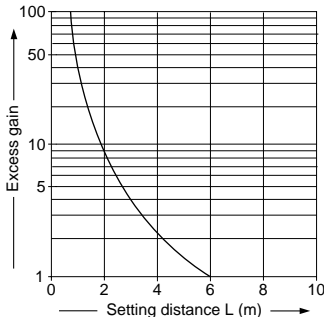

# NA1-5

## SENSING CHARACTERISTICS (TYPICAL)

### Parallel deviation

#### Vertical direction

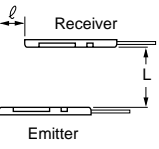

#### Horizontal direction

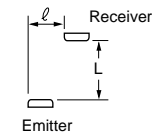

• Common for both horizontal and vertical directions

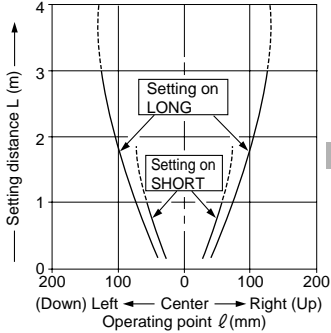

### Angular deviation

#### Emitter angular deviation

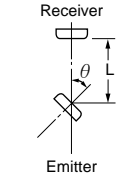

#### Receiver angular deviation

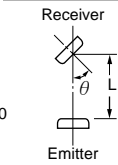

• Setting on LONG

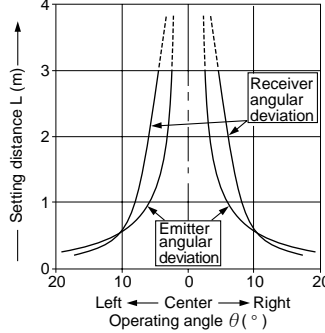

• Setting on SHORT

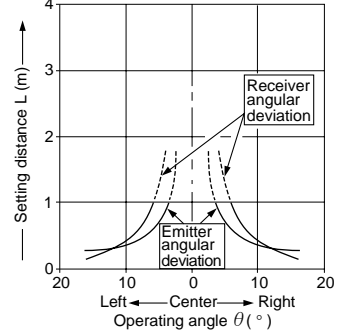

## PRECAUTIONS FOR PROPER USE

Refer to P.820~ for general precautions.

- This sensor is not for press machine safeguard. Do not use this sensor for any press machine.
- This product is not a safety sensor. Its use is not intended or designed to protect life and prevent body injury or property damage from dangerous parts of machinery. It is a normal object detection sensor.
- Area sensors conforming to safety standards are available. For details, please contact our office.

### LONG/SHORT selection switch (incorporated on the emitter)

• Select the switch setting according to the setting distance between the emitter and the receiver as given below.

Setting distance	Operation mode switch
0.05 to 1m	LONG  SHORT
1 to 3m	LONG  SHORT

### Mounting

• Use M4 screws with washers and M4 nuts. The tightening torque should be 0.5N·m or less. (Please arrange the screws and nuts separately.)

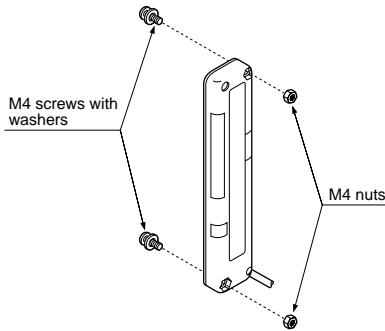

### Selection of output operation

• The output operation mode is selected by the operation mode switch on the receiver.  
 (The switches must be set with the power supply off. The operation mode does not change if the switch setting is changed with the power supplied.)

Output operation	Operation mode switch
ON when one or more beams are interrupted.	SINGLE D / ON  DOUBLE L / ON
OFF when one or more beams are interrupted (ON when all beams are received).	SINGLE D / ON  DOUBLE L / ON
ON when any two or more beams are interrupted.	SINGLE D / ON  DOUBLE L / ON
OFF when any two or more beams are interrupted.	SINGLE D / ON  DOUBLE L / ON

### Orientation

• The emitter and the receiver must face each other correctly. If they are set upside down, the sensor does not work.

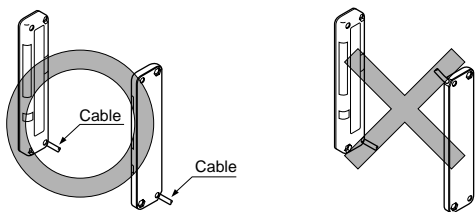

### Job indicator operation selection

• Lighting/Blinking is selected by the operation mode switch on the emitter and the receiver.

	Operation mode switch			
	Emitter		Receiver	
Lighting	LIGHT	FLASH	LIGHT	FLASH
Blinking	LIGHT	FLASH	LIGHT	FLASH

### Others

• Do not use during the initial transient time (0.5 sec.) after the power supply is switched on.



## PRECAUTIONS FOR PROPER USE

Refer to P.820~for general precautions.

### Interference prevention function

- By setting different emission frequencies, two units of **NA1-5** can be mounted close together, as shown in the figure below.

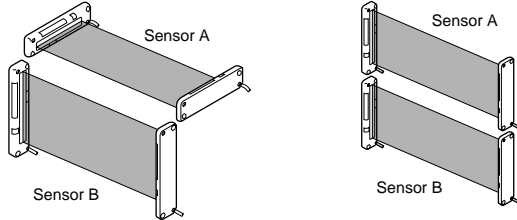

	Operation mode switch			
	Emitter		Receiver	
Sensor A (FREQ. A)	FREQ. A	FREQ. B	FREQ. A	FREQ. B
Sensor B (FREQ. B)	FREQ. A	FREQ. B	FREQ. A	FREQ. B

## DIMENSIONS (Unit: mm)

### NA1-5 NA1-5-PN Sensor

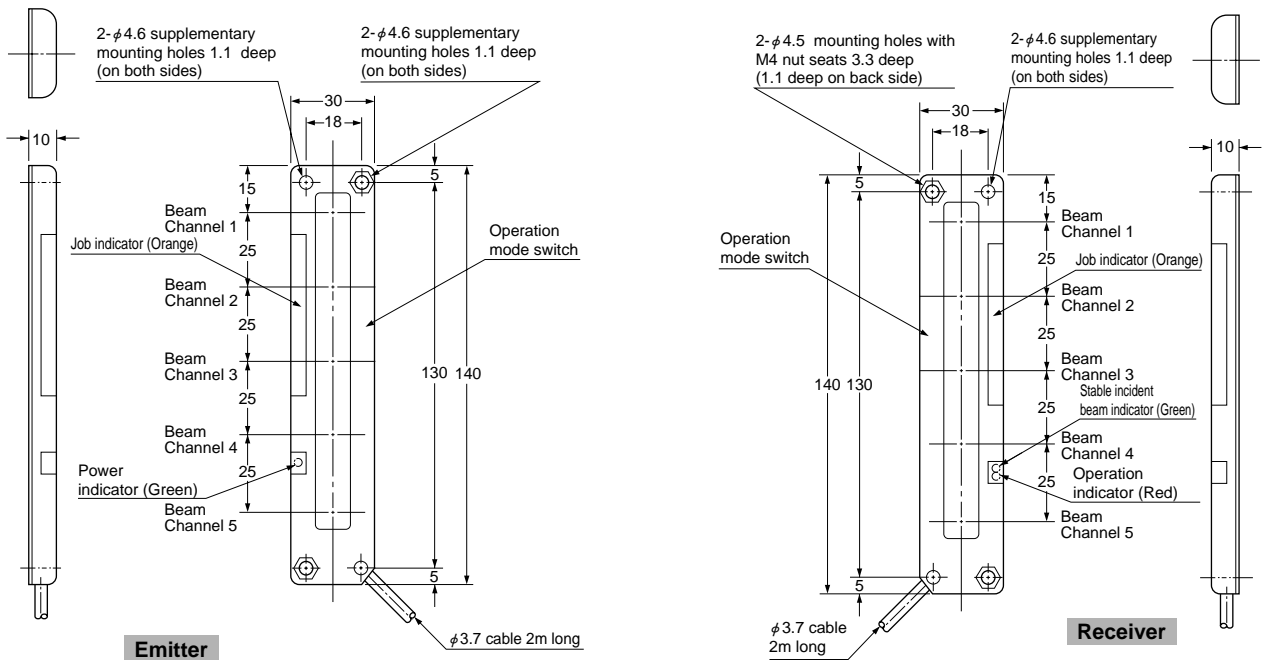

### MS-NA1-1 Sensor mounting bracket (Optional)

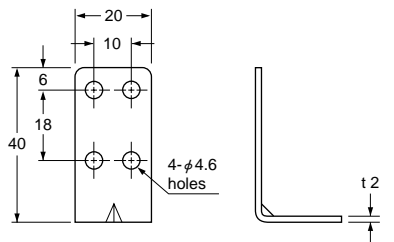

Material: Cold rolled carbon steel (SPCC)  
(Uni-chrome plated)

Four bracket set

- Four M4 (length 15mm) screws with washers, eight nuts, four hooks and eight M4 (length 18mm) screws with washers are attached.
- [ M4 (length 18mm) screws with washers are not used for NA1-5. ]

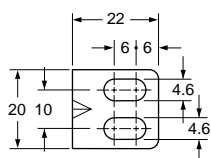

### Assembly dimensions

Mounting drawing with the receiver

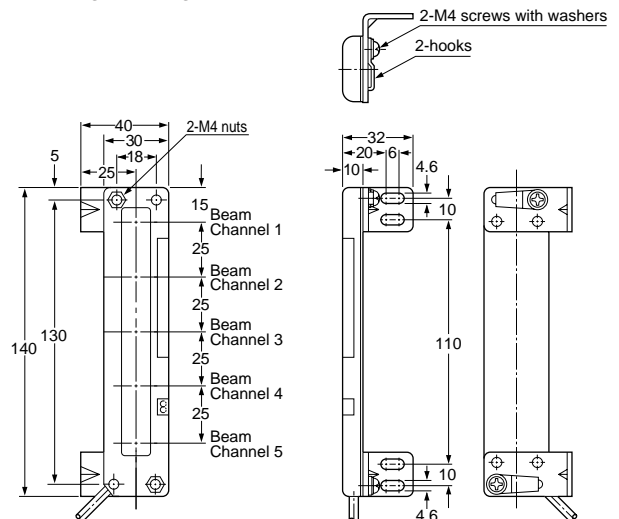

Global Conformance to Safety Standards  
SF1-A SF2-EH

General Use  
NA40 SF1-N

Individual Beam Outputs  
SF1-F

NA2

Slim Body  
NA1-11

NA1-5

# NA1-5

## DIMENSIONS (Unit: mm)

### MS-NA2-1 Sensor mounting bracket (Optional)

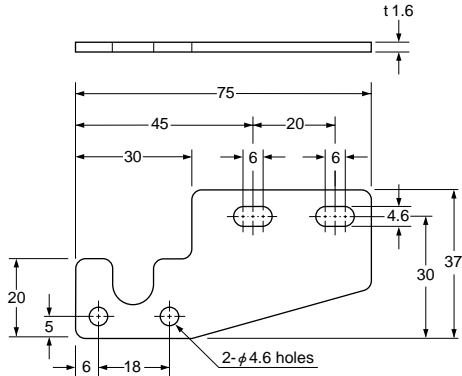

Material: Cold rolled carbon steel (SPCC)  
(Uni-chrome plated)

Four bracket set  
(Four M4 (length 15mm) screws with washers, eight nuts, four hooks, four spacers)  
(and eight M4 (length 18mm) screws with washers are attached.)

### Assembly dimensions

Mounting drawing with the receiver

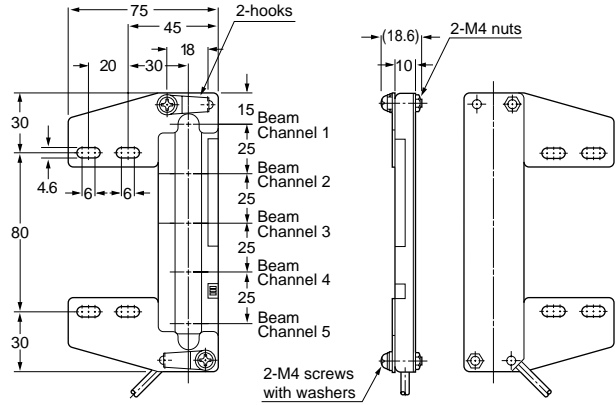

### MS-NA3 Sensor protection bracket (Optional)

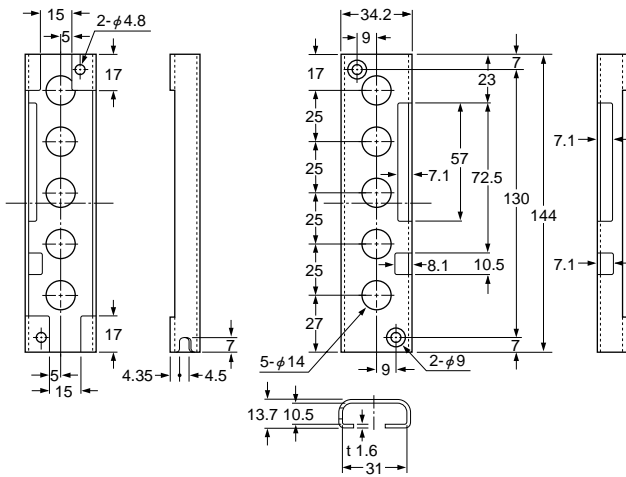

**For receiver**

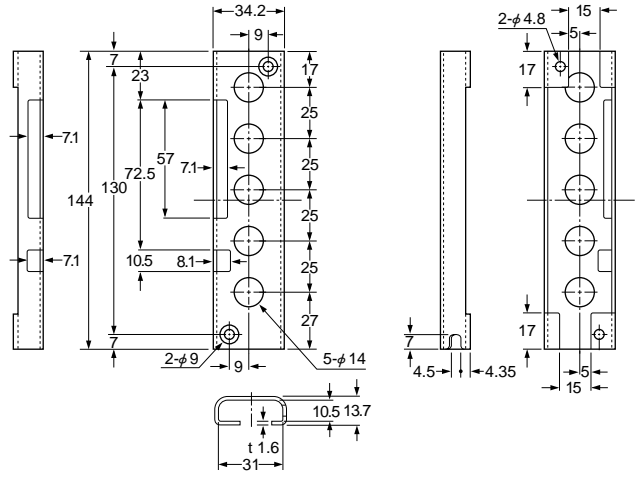

**For emitter**

Material: Cold rolled carbon steel (SPCC)  
(Chrome plated)

Two bracket set  
(Four M4 (length 15mm) screws with washers, and  
four nuts are attached.)