

SWITCH FUNCTION	
POS. 1	POS. 2
ON	(ON)
1-2	3-4

(ON) = MOMENTARY

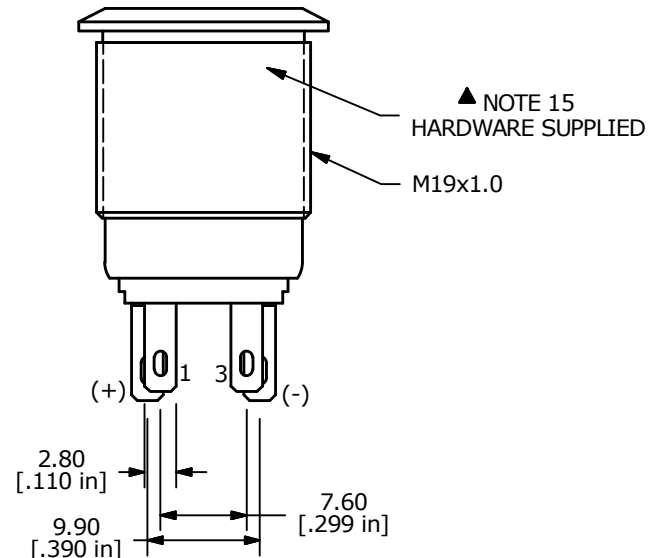

- NOTE:
- ALL DIMENSIONS IN MM [INCH]
 - GENERAL TOLERANCE: X.X=±0.4
X.XX=±0.25
 - TERMINAL NUMBERS FOR REF ONLY
 - CONTACT MATERIAL: SILVER
 - RATING: 2A 24VDC
 - ELECTRIC LIFE: 50,000 MAKE-AND-BREAK CYCLES AT FULL LOAD.
 - INSULATION RESISTANCE: 1,000 MΩ MIN.
 - DIELECTRIC STRENGTH: 2,000 VAC MIN. FOR 1 MINUTE
 - CONTACT RESISTANCE: 50mΩ MAX. @ 1A 12VDC
 - OPERATING TEMP.: -20°C to 55°C
 - TRAVEL: 2.8mm
 - ▲ DENOTES CRITICAL PARAMETER.
 - LAMP VOLTAGE: 12V
 - INGRESS PROTECTION: IP65
 - HARDWARE SUPPLIED: O-RING AND HEXNUT
 - ILLUMINATION COLOR: WHITE

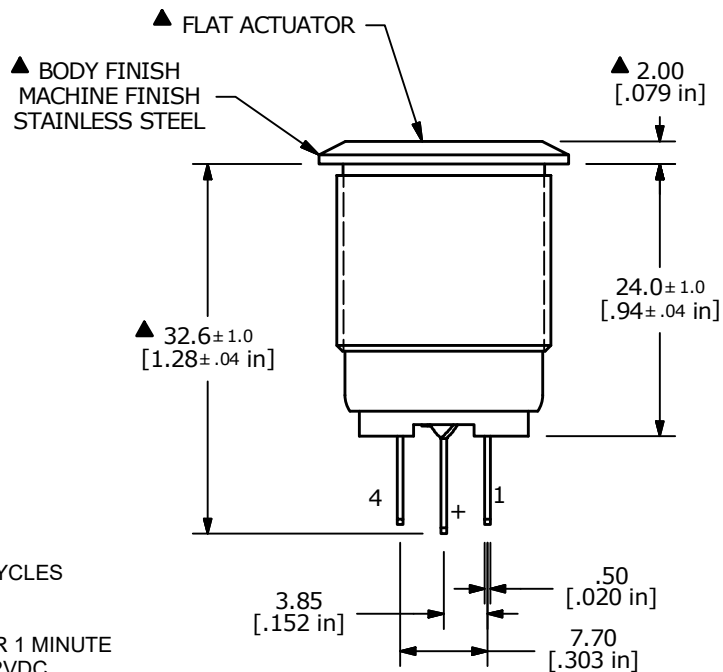
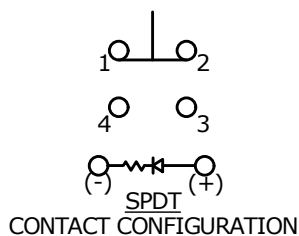
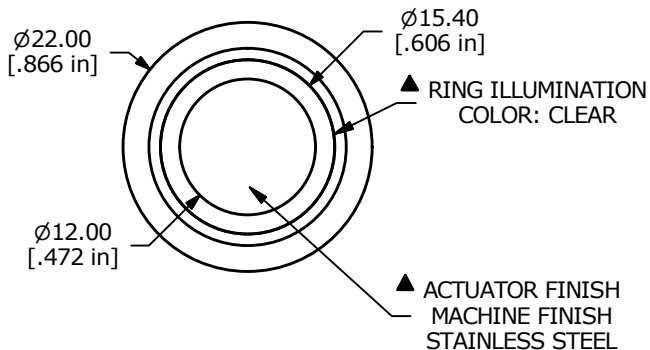

B	23602	UPDATED RATING TO 2A @ 24VDC	10/10/18	MJR
A	20214	RELEASE FOR PRODUCTION	10/14/11	BGL
REV	PCR NO	DESCRIPTION	DATE	BY

TITLE PV4F2Y0SS-304				
SCALE 3:2	DATE 10/14/2011	DR BGL	DWG 52-PV4F2Y0SS304	REV B

THE INFORMATION CONTAINED IN THIS DOCUMENT IS PROPRIETARY TO E-SWITCH AND IS NOT TO BE COPIED OR TRANSFERRED