



深圳市雅晶鑫电子有限公司
Shenzhen Yajingxin Electron Co.,Ltd

产品ITEM: 石英晶体谐振器 QUARTZ CRYSTAL UNITS

型号TYPE: SMD-5032_2PIN_GA (TXM12.000M2503LDCE-O00T)

标称频率NOMINAL FREQUENCY: 12.000MHz /20PF +/-20PPM



拟制Prepared by: 郑利

批准Confirmed by: 李虹

RoHS Compliant Standard

T-5032-2PIN-GLASS

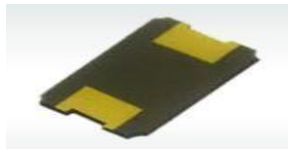

Features 特性

- Nominal Frequency 标称频率: 12.000MHz
- Suited for portable devices with low current consumption
適合於低功耗的便攜設備
- For a clock source in electronic equipments 適用於电子設備的時鐘源

Item	Model	T-5032-2PIN-GLASS	Conditions
Frequency Range	标称频率	12.000MHz	
Frequency Tolerance	調整頻差	±20ppm Max	at 25°C
Freq. Tol. Over Temp.	溫度頻差	±30ppm Max	-40~+85°C
Operating Temp. Range	工作溫度範圍	-40~+85°C	
Storage Temp. Range	保存溫度範圍	-55~+125°C	
Series Resistance	諧振電阻	50Ω Max	
Load Capacitance	負載電容	20pF	
Shunt Capacitance	靜態電容	7.0pF Max	
Drive Level	激勵電平	100μw Max	
Aging	老化率	±3ppm/year Max	
Insulation Resistance	絕緣阻抗	500Mohm/Min	DC100V±15V

OUTLINE DIMENSIONS (unit: mm)

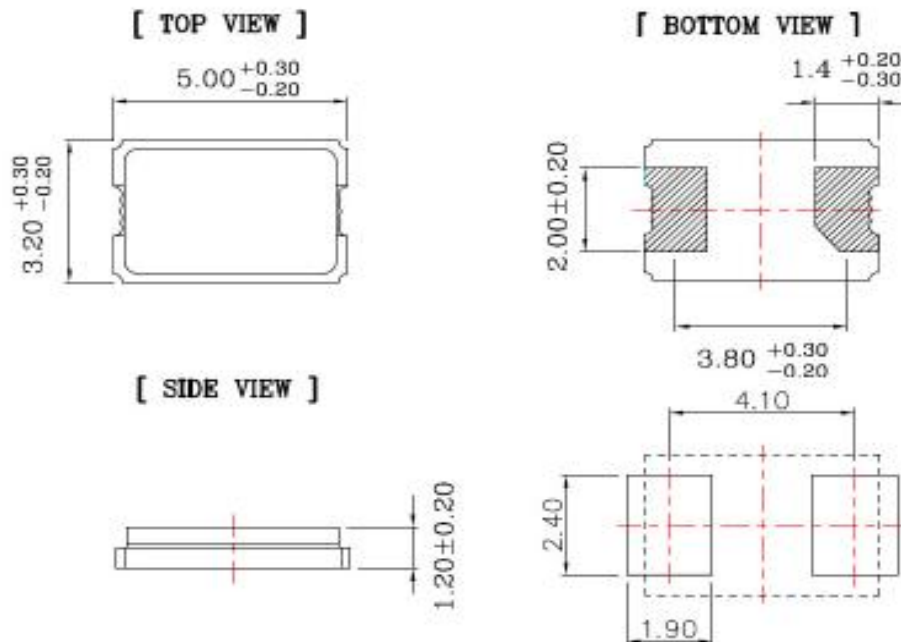

深圳市雅晶鑫电子有限公司
Shenzhen Yajingxin Electron Co.,Ltd

可靠性Reliability(Mechanical and Environmental Endurance)

序号 NO	项目 ITEM	条件 CONDITIONS	合格标准 BASIS OF VERDICT
1	跌落 Drop	100cm高处自由跌落到3cm厚硬木板上,3次 High:100cm;Thickness:3cm;3 times	$\Delta FL \leq \pm 5 \text{ppm}$ $\Delta RS \leq 5 \Omega \text{ or } \pm 15\%$ (whichever is larger)
2	振动 Vibration	频率 Frequency: 10~2000Hz; 加速度幅度 Acceleration: 100 m/s ² 振 动方向 Direction: X, Y, Z 振动时间 Duration: 每个方向30分钟 30 min/direction. 循环次数 Times: 12次	$\Delta FL \leq \pm 5 \text{ppm}$ $\Delta RS \leq 5 \Omega \text{ or } \pm 15\%$ (Whichever is Larger)
3	热冲击 Thermal shock	-55℃~+125℃, 1000个循环 最大转换时间: 5分钟; 停留时间: 5分钟 -55℃~+125℃, For 1000 cycles Maximum conversion time: 5 minutes;Remain time:5 minutes	$\Delta FL \leq \pm 10 \text{ppm}$ $\Delta RS \leq 5 \Omega \text{ or } \pm 20\%$ (Whichever is Larger)
4	湿热 Humidity	温度:85℃;湿度:85%;时间:1000小时 Temp:85℃;Humidity:85%;Times:1000h	$\Delta FL \leq \pm 10 \text{ppm}$ $\Delta RS \leq 5 \Omega \text{ or } \pm 20\%$ (Whichever is Larger)
5	低温 Cold resistance	温度:-40℃;时间:1000小时 Temp:-40℃;Times:1000h	$\Delta FL \leq \pm 10 \text{ppm}$ $\Delta RS \leq 5 \Omega \text{ or } \pm 20\%$ (Whichever is Larger)
6	湿度抗性 Humidity resistance	高温: 65℃ (10小时, 含升温), 低温: 25℃ (2小时, 含降温), 湿度90%, 循环10次, 每循环24小时 High-Temperature: 65℃±2℃ (10 hours, including heating), Low-Temperature: 25℃±2℃ (2 hours, including cooling), Humidity: 90%, for 10 cycles (24 hours/cycle)	$\Delta FL \leq \pm 10 \text{ppm}$ $\Delta RS \leq 5 \Omega \text{ or } \pm 20\%$ (Whichever is Larger)
7	机械冲击 Mechanical shock	峰值 Peak: 100g's 持续时间 Duration: 6ms 波形 Waveform: 半正弦波 Half-sine 变化速度 Velocity Change: 12.3 ft / sec 振动方向 Direction: +X, -X, +Y, -Y, +Z, -Z 每个方向各3次 3 times/direction	$\Delta FL \leq \pm 5 \text{ppm}$ $\Delta RS \leq 5 \Omega \text{ or } \pm 15\%$ (Whichever is Larger)

深圳市雅晶鑫电子有限公司
Shenzhen Yajingxin Electron Co.,Ltd

可靠性 Reliability (Mechanical and Environmental Endurance)

序号 NO	项目 ITEM	条件 CONDITIONS	合格标准 BASIS OF VERDICT
8	回流焊 Reflow	<p>260°C±5°C</p> <p>150°C±5°C</p> <p>120sec</p> <p>10secmax</p> <p>CYCLE TIME周期: 200 sec Max.</p>	<p>△FL≤±5ppm</p> <p>△RS≤5 Ω or±15% (Whichever is Larger)</p> <p>No Rusty</p>
9	引脚拉力(SMD型) Pin pull	<p>按照要求分别提供1.8kg的切向推力（60秒）以及1.8kg的垂直拉力（60秒）</p> <p>In accordance with the requirements, offering 1.8kg tangential thrust (60 seconds), and 1.8kg vertical pull (60 seconds) respectively.</p>	<p>电极不断裂</p> <p>No Rupture Observed</p>
10	老化 Aging	<p>温度:85°C ;时间:1000小时</p> <p>Temp:85°C ;Times:1000h</p>	<p>△FL≤±10ppm</p> <p>△RS≤5 Ω or±10% (Whichever is Larger)</p>
11	可焊性 solderability	<p>温度: 235°C±5°C; 时间: 2秒</p> <p>Temperature: 235°C±5°C; Time: 2sec</p>	<p>浸锡率≥95%</p> <p>Solder Coverage≥95%</p>
备注	可靠性项目中的4、5、6、10，需在试验结束后24±2小时进行测试。		