

LA SERIES

Related Information

- General terms and conditions..... F-3
- Selection guide P.1021~
- About laser beam..... P.1593~
- General precautions P.1595

- FIBER SENSORS
- LASER SENSORS
- PHOTOELECTRIC SENSORS
- MICRO PHOTOELECTRIC SENSORS
- AREA SENSORS
- SAFETY LIGHT CURTAINS / SAFETY COMPONENTS
- PRESSURE / FLOW SENSORS
- INDUCTIVE PROXIMITY SENSORS
- PARTICULAR USE SENSORS
- SENSOR OPTIONS
- SIMPLE WIRE-SAVING UNITS
- WIRE-SAVING SYSTEMS
- MEASUREMENT SENSORS
- STATIC CONTROL DEVICES
- LASER MARKERS
- PLC
- HUMAN MACHINE INTERFACES
- ENERGY MANAGEMENT SOLUTIONS
- FA COMPONENTS
- MACHINE VISION SYSTEMS
- UV CURING SYSTEMS
- Selection Guide
- Laser Displacement
- Magnetic Displacement
- Contact Displacement
- Collimated Beam Sensors
- Metal-sheet Double-feed Detection
- Digital Panel Controller
- Other Products
- HL-T1
- LD
- LA

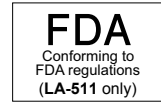
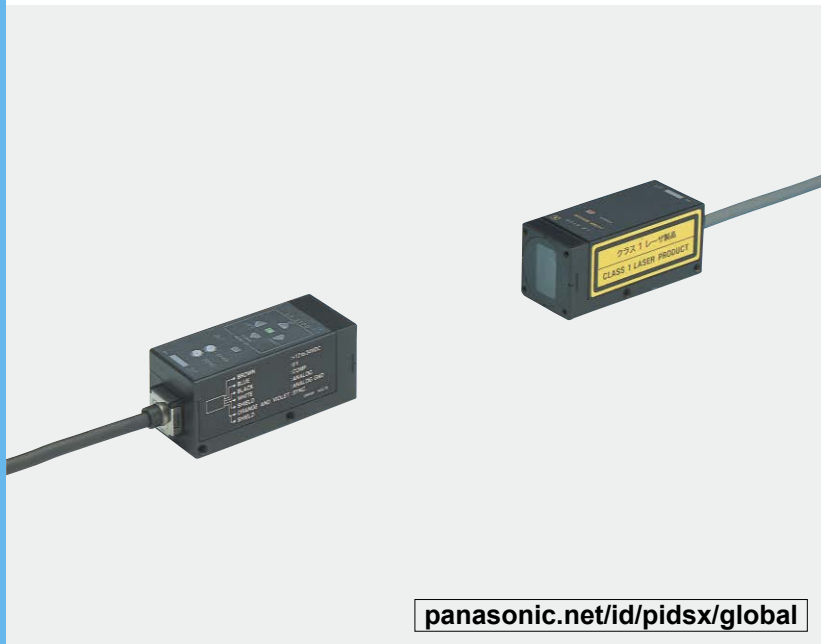

LA-510 is classified as a Class 1 Laser Product in IEC / JIS standards. **LA-511** is a Class I Laser Product in FDA regulations. Do not look at the laser beam through optical system such as a lens.

panasonic.net/id/pidsx/global

“Class 1” laser beam sensor safe for your eyes

BASIC PERFORMANCE

Safety countermeasures not required **LA-510**

This laser collimated beam sensor conforms to the Class 1 laser stipulated in IEC 60825-1 and JIS C 6802. Hence, safety measures such as protective gear are not necessary.

Precise sensing in wide area

Sensing area: 15 × 500 mm **0.591 × 19.685 in**
 Minimum sensing object: ø0.1 mm **ø0.004 in**
 Repeatability: 10 µm **0.394 mil** or less

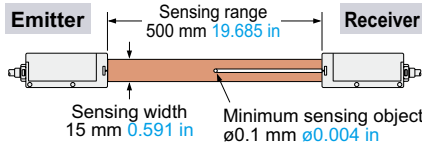

VARIETIES

FDA Class I type **LA-511**

LA-511 conforms to FDA Class I. It is approved for use in U.S.A. by FDA.

FUNCTIONS

Easy laser beam alignment

Four monitoring LEDs help you to easily align the emitter and the receiver.

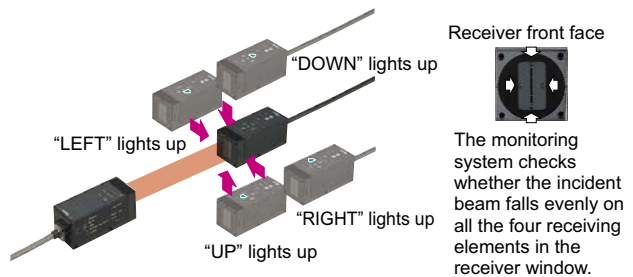

OPTIONS

Versatile mounting

The side view attachment (optional) enables versatile mounting styles.

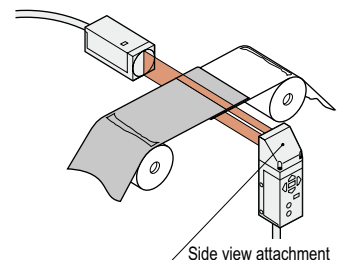

APPLICATIONS

Accurate positioning of orientation flat

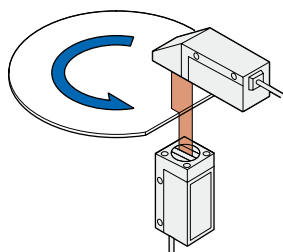

Counting number of O-rings

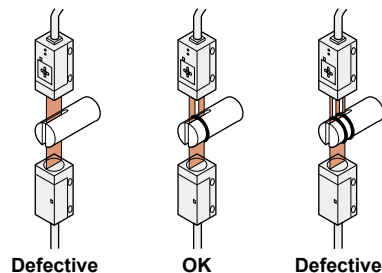

Positioning gear on polishing machine

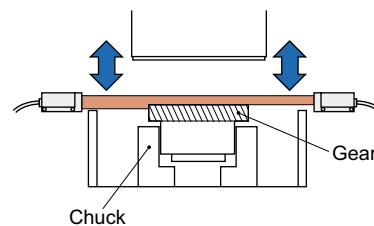

ORDER GUIDE

Laser collimated beam sensors

Type	Appearance	Model No.	Conforming standards / regulations	Output
Class 1 type		LA-510	IEC and JIS standards	NPN open-collector transistor (Comparative output) Analog voltage • Output voltage: 1 to 5 V
		LA-511	FDA regulations	

Note: The model No. with "P" shown on the label affixed to the product is the emitter, "D" shown on the label is the receiver.

Accessory

- **MS-LA1** (Sensor mounting bracket)

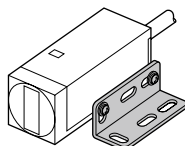

Set of two L-shaped brackets and four M4 (length 8 mm 0.315 in) screws with washers.

Note: 2 sets are required to mount the emitter and the receiver.

OPTIONS

Designation	Model No.	Description
Side view attachment (Note 1)	LA-SV1	Versatile mounting is possible as the laser beam can be bent at a right angle. <ul style="list-style-type: none"> • Sensing range: 500 mm 19.685 in • Minimum sensing object: ø0.1 mm ø0.004 in • Repeatability: 20 µm 0.787 mil or less
Digital panel controller (Note 2)	CA2-T2	This is a very small controller which allows two independent threshold level settings. <ul style="list-style-type: none"> • Supply voltage: 24 V DC ±10 % • No. of inputs: 1 No. (sensor input) • Input range: 1 to 5 V DC • Output: NPN open-collector transistor • Main functions: Threshold level setting function, zero-adjust function, scale setting function, hysteresis setting function, start/hold function, auto-reference function, power supply ON-delay function, etc.

Notes: 1) Mount **LA-SV1** on either the emitter or the receiver. If it is mounted on both sides, the monitor LEDs may not light off perfectly.
 2) Refer to p.1143~ the ultra-compact digital panel controller **CA2** series.

Side view attachment

- **LA-SV1**

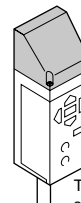

Two M3 (length 10 mm 0.394 in) screws with washers are attached.

Digital panel controller

- **CA2-T2**



- FIBER SENSORS
- LASER SENSORS
- PHOTO-ELECTRIC SENSORS
- MICRO PHOTO-ELECTRIC SENSORS
- AREA SENSORS
- SAFETY LIGHT CURTAINS / SAFETY COMPONENTS
- PRESSURE / FLOW SENSORS
- INDUCTIVE PROXIMITY SENSORS
- PARTICULAR USE SENSORS
- SENSOR OPTIONS
- SIMPLE WIRE-SAVING UNITS
- WIRE-SAVING SYSTEMS
- MEASURE-MENT SENSORS
- STATIC CONTROL DEVICES
- LASER MARKERS
- PLC
- HUMAN MACHINE INTERFACES
- ENERGY MANAGEMENT SOLUTIONS
- FA COMPONENTS
- MACHINE VISION SYSTEMS
- UV CURING SYSTEMS

- Selection Guide
- Laser Displacement
- Magnetic Displacement
- Contact Displacement
- Collimated Beam Sensors
- Metal-sheet Double-feed Detection
- Digital Panel Controller
- Other Products

- HL-T1
- LD
- LA

SPECIFICATIONS

Laser collimated beam sensors

Item	Type	Class 1 type	
	Conforming standards / regulations	IEC and JIS standards	FDA regulations
Model No.		LA-510	LA-511
CE marking directive compliance		EMC Directive, RoHS Directive	
Sensing width		15 mm 0.591 in	
Sensing range		500 mm 19.685 in	
Min. sensing object		ø0.1 mm ø0.004 in opaque object	
Repeatability		10 µm 0.394 mil or less	
Supply voltage		12 to 24 V DC ±10 % Ripple P-P 10 % or less	
Current consumption		Emitter: 35 mA or less, Receiver: 25 mA or less	
Comparative output		NPN open-collector transistor <ul style="list-style-type: none"> • Maximum sink current: 100 mA • Applied voltage: 30 V DC or less (between comparative output and 0 V) • Residual voltage: 1 V or less (at 100 mA sink current) 0.4 V or less (at 16 mA sink current) 	
Utilization category		DC-12 or DC-13	
Response time		0.5 ms or less	
Output operation		ON when the incident beam amount is less than the threshold level	
Short-circuit protection		Incorporated	
Analog output		Analog voltage <ul style="list-style-type: none"> • Output voltage: 1 V (Darkest) to 5 V (Lightest) • Output impedance: 75 Ω 	
Slew rate		8 V/ms or more	
Temperature characteristics		Within ±0.1 % F.S./°C (with respect to sensing range at ambient temperature +20 °C +68 °F)	
Remote interlock input		Laser is emitted when it is connected to 0 V, but not emitted when connected to +V or kept open	
Indicators	Operation	Red LED (lights up when the comparative output is ON)	
	Laser emission warning	Red LED (lights up when laser is being emitted)	
	Stable incident beam	Green LED (lights up under the stable light received condition)	
	Laser beam alignment	Yellow LED × 4 (light up when laser beam is misaligned)	
Adjusters	Threshold level	Adjustment of threshold level for the comparative output, 18-turn endless adjuster	
	Span	Adjustment of span for the analog voltage output, 18-turn endless adjuster	
Environmental resistance	Pollution degree	3 (Industrial environment)	
	Ambient temperature	0 to +50 °C +32 to +122 °F (No dew condensation allowed), Storage: -20 to +70 °C -4 to +158 °F	
	Ambient humidity	35 to 85 % RH, Storage: 35 to 85 % RH	
	Ambient illuminance	Incandescent light: 10,000 lx or less at the light-receiving face	
	Insulation resistance	20 MΩ, or more, with 250 V DC megger between all supply terminals connected together and enclosure	
	Vibration resistance	10 to 55 Hz frequency, 1.5 mm 0.059 in double amplitude in X, Y and Z directions for two hours each	
Shock resistance	500 m/s ² acceleration (50 G approx.) in X, Y and Z directions three times each		
Emitting element		Infrared semiconductor laser diode (Maximum output: 1.7 mW, Peak emission wavelength: 780 nm 0.031 mil)	
Enclosure earthing		Capacitor earth	
Material		Enclosure: Die-cast zinc alloy, Top cover: PPO, Front protection cover: Glass	
Cable		0.2 mm ² 5-core (emitter: 4-core) shielded cable, 3 m 9.843 ft long	
Cable extension (Note 2)		Extension up to total 50 m 164.042 ft is possible, for both emitter and receiver, with 0.3 mm ² , or more, cable. (Synchronization wire cannot be extended.)	
Net weight		Emitter: 290 g approx., Receiver: 280 g approx.	
Accessories		MS-LA1 (Sensor mounting bracket): 1 set for emitter and receiver Adjusting screwdriver: 1 pc. Crimp contact: 2 pcs. Class 1 identification label: 1 pc. (LA-510 only) Inspection slip: 1 pc. (LA-511 only)	

Notes: 1) Where measurement conditions have not been specified precisely, the conditions used were an ambient temperature of +20 °C **+68 °F**.

2) **LA-510** and **LA-511** are CE compliant and complies with EMC directives. EN 61000-6-2 is the applicable standard that covers immunities relating to use of this product, but in order to comply with this standard, the following conditions must be satisfied.

Conditions

- This sensor should be connected less than 10 m **32.808 ft** from the power supply.
- The signal line to connect with this sensor should be less than 30 m **98.425 ft**.

I/O CIRCUIT AND WIRING DIAGRAMS

LA-510 LA-511

Laser collimated beam sensor

I/O circuit diagram

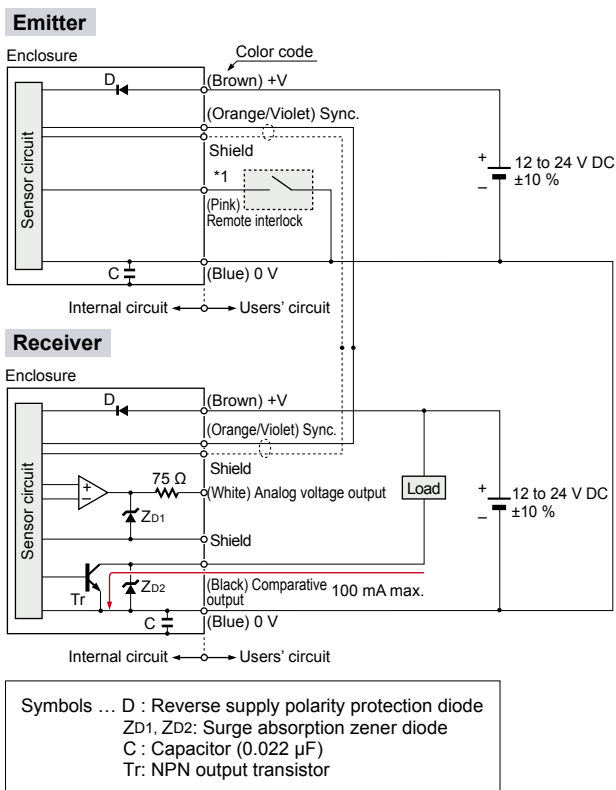

Wiring diagram

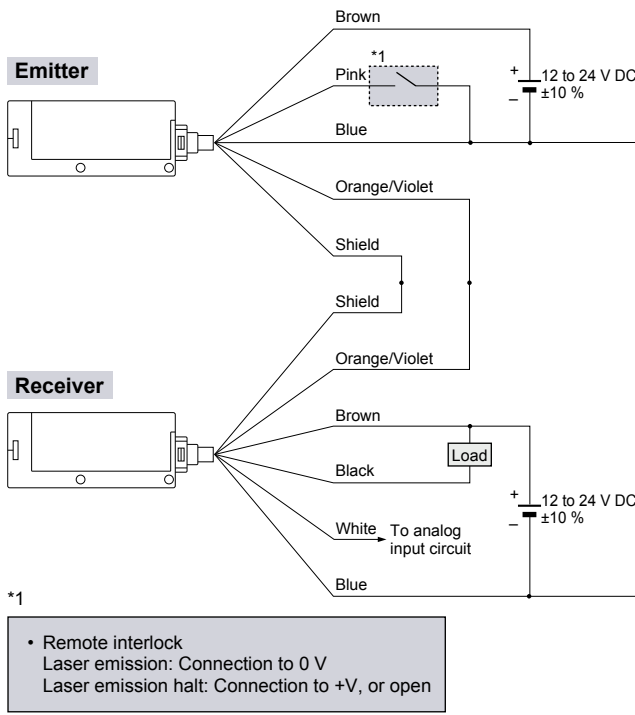

SENSING CHARACTERISTICS (TYPICAL)

Correlation between setting distance and excess gain

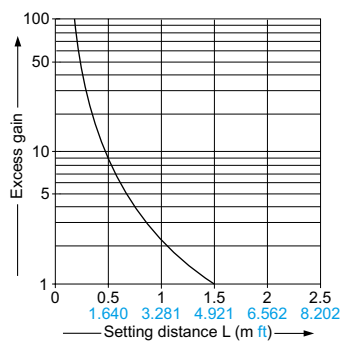

Correlation between transverse deviation and output voltage

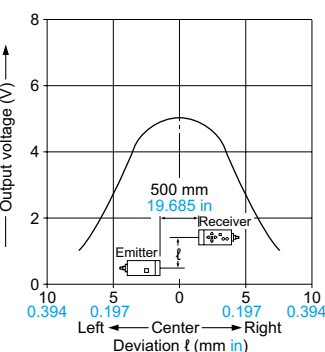

Correlation between interrupted beam width and output voltage

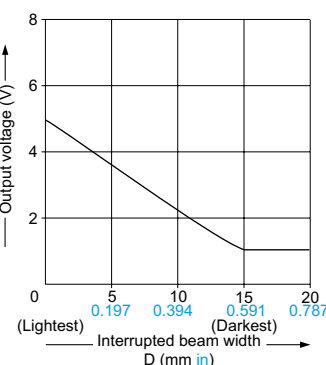

Correlation between ambient temperature and output voltage variation rate

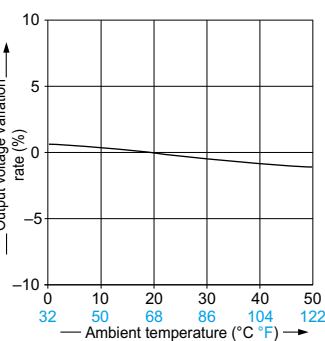

FIBER SENSORS

LASER SENSORS

PHOTO-ELECTRIC SENSORS

MICRO PHOTO-ELECTRIC SENSORS

AREA SENSORS

SAFETY LIGHT CURTAINS / SAFETY COMPONENTS

PRESSURE / FLOW SENSORS

INDUCTIVE PROXIMITY SENSORS

PARTICULAR USE SENSORS

SENSOR OPTIONS

SIMPLE WIRE-SAVING UNITS

WIRE-SAVING SYSTEMS

MEASURE-MENT SENSORS

STATIC CONTROL DEVICES

LASER MARKERS

PLC

HUMAN MACHINE INTERFACES

ENERGY MANAGEMENT SOLUTIONS

FA COMPONENTS

MACHINE VISION SYSTEMS

UV CURING SYSTEMS

Selection Guide

Laser Displacement

Magnetic Displacement

Contact Displacement

Collimated Beam Sensors

Metal-sheet Double-feed Detection

Digital Panel Controller

Other Products

HL-T1

LD

LA

PRECAUTIONS FOR PROPER USE

Refer to p.1595 for general precautions and p.1593~ for information about laser beam.

FIBER
SENSORSLASER
SENSORSPHOTO-
ELECTRIC
SENSORSMICRO
PHOTO-
ELECTRIC
SENSORSAREA
SENSORSSAFETY LIGHT
CURTAINS /
SAFETY
COMPONENTSPRESSURE /
FLOW
SENSORSINDUCTIVE
PROXIMITY
SENSORSPARTICULAR
USE
SENSORSSENSOR
OPTIONSSIMPLE
WIRE-SAVING
UNITSWIRE-SAVING
SYSTEMSMEASURE-
MENT
SENSORSSTATIC
CONTROL
DEVICESLASER
MARKERS

PLC

HUMAN
MACHINE
INTERFACESENERGY
MANAGEMENT
SOLUTIONSFA
COMPONENTSMACHINE
VISION
SYSTEMSUV
CURING
SYSTEMSSelection
GuideLaser
DisplacementMagnetic
DisplacementContact
DisplacementCollimated
Beam
SensorsMetal-sheet
Double-feed
DetectionDigital Panel
ControllerOther
Products

HL-T1

LD

LA

Laser collimated beam sensor

- This catalog is a guide to select a suitable product. Be sure to read the instruction manual attached to the product prior to its use.



- Never use this product as a sensing device for personnel protection.
- In case of using sensing devices for personnel protection, use products which meet laws and standards, such as OSHA, ANSI or IEC etc., for personnel protection applicable in each region or country.



- This product is classified as a Class 1 Laser Product in IEC / JIS standards and a Class I Laser Product in FDA regulations. Do not look at the laser beam through optical system such as a lens.
- The following label is enclosed with this product. Handle the product according to the instruction given on the warning label.

Class 1 type



(The English warning label based on FDA regulations is pasted on the FDA regulations conforming type.)

Mounting

- The emitter and the receiver must face each other with proper slit orientation so that the beam can be received.
- The tightening torque should be 1.17 N·m or less. When mounting the sensor with the attached sensor mounting bracket, the sensor must be fixed on both sides.

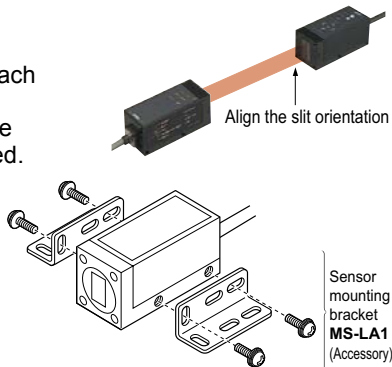
**Wiring**

- In LA-510 and LA-511, capacitor earth is used to enhance the noise characteristics. In case there is a high frequency noise generating equipment, such as, an ultrasonic welding machine, etc., near the sensor head and if the mounting base is electrically conducting (metallic, etc.), then insulate the sensor head from the mounting base.

Do not use a power supply having a single-winding transformer (auto-transformer) as this can be dangerous.

Safety standards for laser beam products

- A laser beam can harm human being's eyes, skin, etc., because of its high energy density. IEC has classified laser products according to the degree of hazard and the stipulated safety requirements. **LA-510** is identified as a "Class 1" laser product.

Classification by IEC 60825-1

Classification	Description
Class 1	Lasers that are safe under reasonably foreseeable conditions of operation, including the use of optical instruments for intrabeam viewing.

Note: Refer to p.1594 for information about Laser Beam for the classification in FDA regulations.

Safe use of laser products

- For the purpose of preventing users from suffering injuries by laser products, IEC 60825-1 (Safety of laser products). Please check the standards before use. (Refer to p.1593~ for information about laser beam.)

Others

- The sensor's output is proportional to the amount of laser beam received. Since there is some variation in the light intensity at the center and the periphery of the sensing area, take care that "output = dimension" may not hold.
- For stable operation, use the sensor 10 min., or more, after switching on the power supply.

DIMENSIONS (Unit: mm in)

The CAD data can be downloaded from our website.

LA-510 LA-511

Laser collimated beam sensor

Emitter

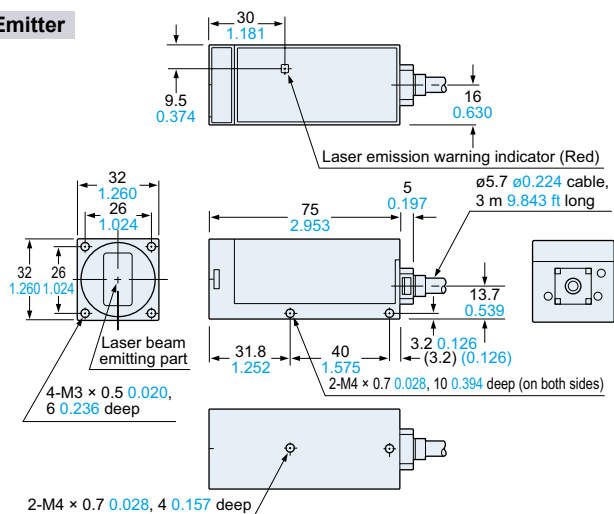

Receiver

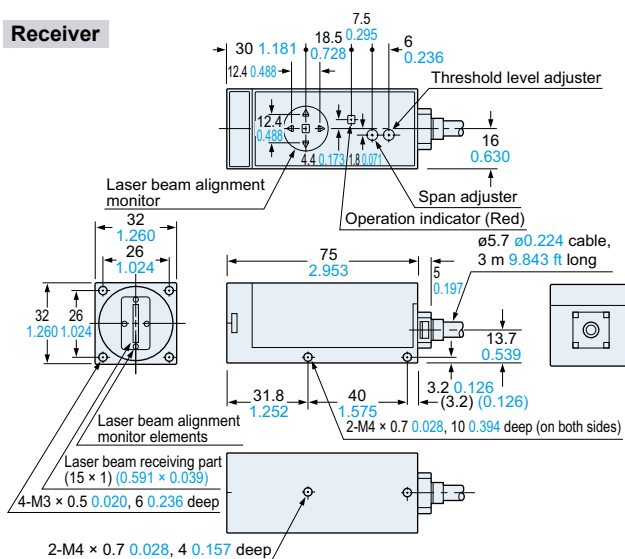

MS-LA1

Sensor mounting bracket (Accessory for LA-510 and LA-511)

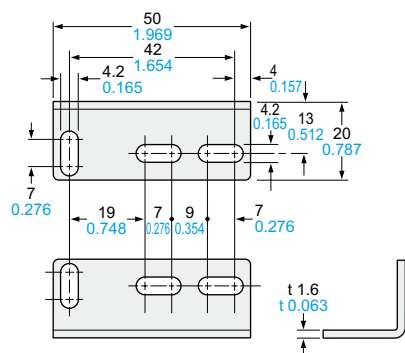

Material: Cold rolled carbon steel (SPCC) (Uni-chrome plated)
Set of two L-shaped brackets and four M4 (length 8 mm 0.315 in) screws with washers

Assembly dimensions

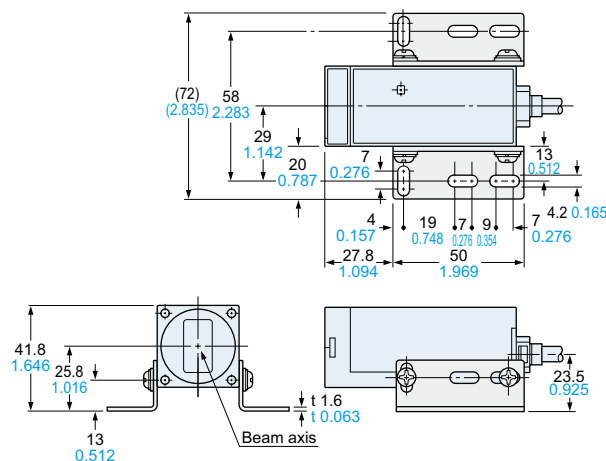

LA-SV1

Side view attachment (Optional)

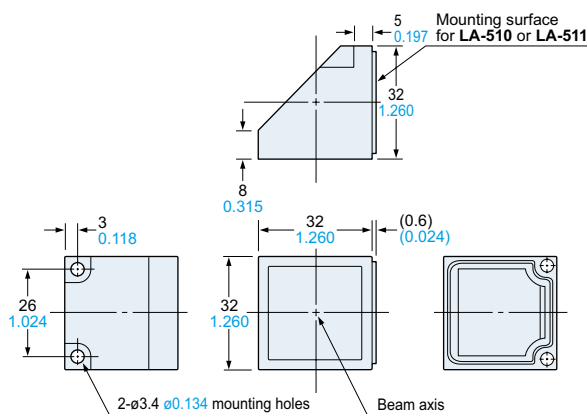

Material: Glass (Front protection cover, Aluminum evaporated mirror) Polyetherimide (Enclosure)
Two M3 (length 10 mm 0.394 in) screws with washers are attached.

Assembly dimensions

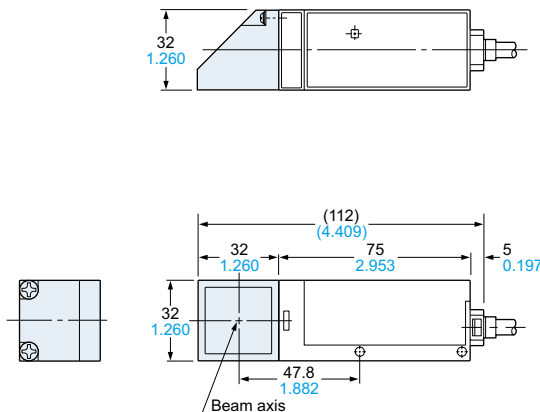

FIBER SENSORS

LASER SENSORS

PHOTO-ELECTRIC SENSORS

MICRO PHOTO-ELECTRIC SENSORS

AREA SENSORS

SAFETY LIGHT CURTAINS / SAFETY COMPONENTS

PRESSURE / FLOW SENSORS

INDUCTIVE PROXIMITY SENSORS

PARTICULAR USE SENSORS

SENSOR OPTIONS

SIMPLE WIRE-SAVING UNITS

WIRE-SAVING SYSTEMS

MEASUREMENT SENSORS

STATIC CONTROL DEVICES

LASER MARKERS

PLC

HUMAN MACHINE INTERFACES

ENERGY MANAGEMENT SOLUTIONS

FA COMPONENTS

MACHINE VISION SYSTEMS

UV CURING SYSTEMS

Selection Guide

Laser Displacement

Magnetic Displacement

Contact Displacement

Collimated Beam Sensors

Metal-sheet Double-feed Detection

Digital Panel Controller

Other Products

HL-T1

LD

LA