

**DESIGNED AND DIMENSIONED
IN MILLIMETERS UNLESS OTHERWISE STATED**

QSPR-XX

STYLE

- 01: BOARD TO BOARD (SHEET 2, FIG. 2)
- 02: BOARD TO HFEM2 FLEX (SHEET 2, FIG. 3)
- 03: BOARD TO HFEM FLEX (SHEET 2, FIG. 3)

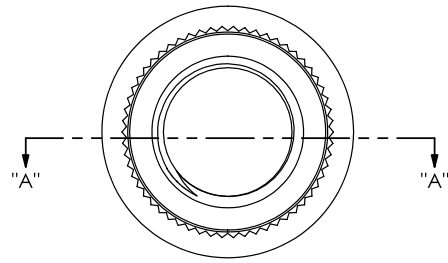
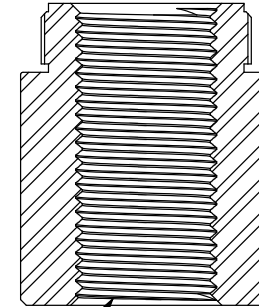
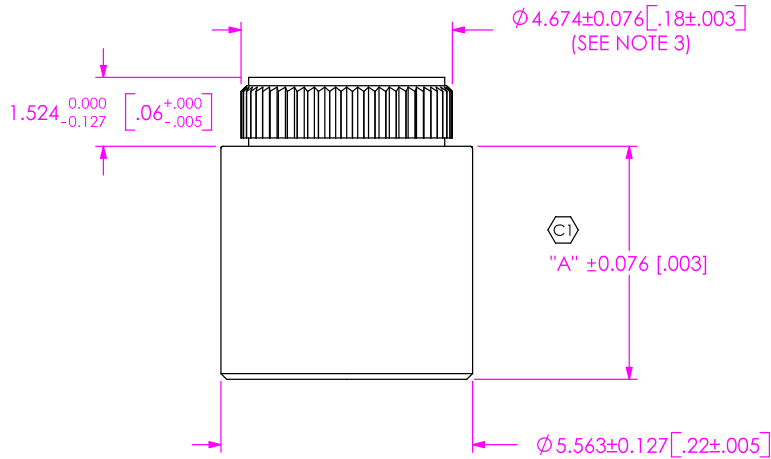
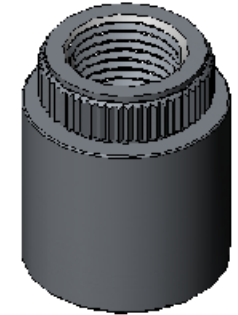

FIG. 1

TABLE 1	
STYLE	"A"
-01	5.150 [.2028]
-02	5.410 [.2130]
-03	5.612 [.2209]



#4-40 THREAD

SECTION "A"- "A"

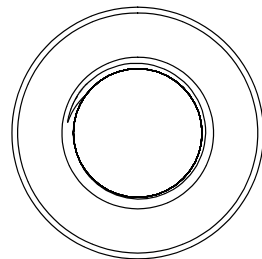

NOTES:

1. Ⓢ REPRESENTS A CRITICAL DIMENSION.
2. STANDOFF TO ACCEPT #4-40 THREADS.
3. STANDOFFS TO BE USED WITH .062" THICK BOARDS.
RECOMMENDED NON-PLATED HOLE SIZE IN PC BOARD: 4.52[.178]
4. PARTS TO BE PACKAGED IN BAGS.

UNLESS OTHERWISE SPECIFIED,
DIMENSIONS ARE IN INCHES.
TOLERANCES ARE:
DECIMALS ANGLES
.XX: ±.01 [.3] 2°
.XXX: ±.003 [.08]
.XXXX: ±.0015 [.038]

PROPRIETARY NOTE

THIS DOCUMENT CONTAINS INFORMATION
CONFIDENTIAL AND PROPRIETARY TO
SAMTEC, INC. AND SHALL NOT BE REPRODUCED
OR TRANSFERRED TO OTHER DOCUMENTS OR
DISCLOSED TO OTHERS OR USED FOR ANY
PURPOSE OTHER THAN THAT WHICH IT WAS
OBTAINED WITHOUT THE EXPRESSED WRITTEN
CONSENT OF SAMTEC, INC.

SAMTEC

520 PARK EAST BLVD, NEW ALBANY, IN 47150
* PHONE: 812.944.6733 FAX: 812.948.5047
e-Mail: INFO@SAMTEC.COM CODE: 55322

MATERIAL:
BRASS

DO NOT SCALE DRAWING



DESIGNED WITH



F:\DWG\MISC\MKTG\QSPR-XX-MKT.SLDDRW

SHEET SCALE: 1:0.16666666666666666

DESCRIPTION:

QXX SERIES STANDOFF

DWG. NO.

QSPR-XX

BY: CLAY W

10/17/2005

SHEET 1 OF 2

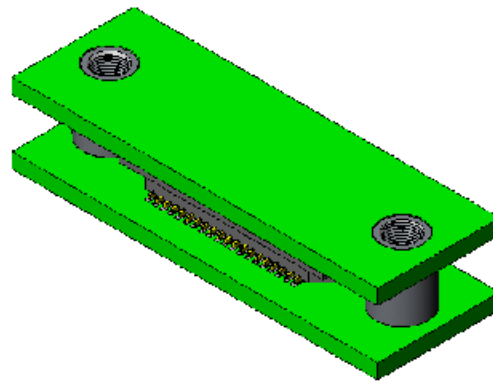
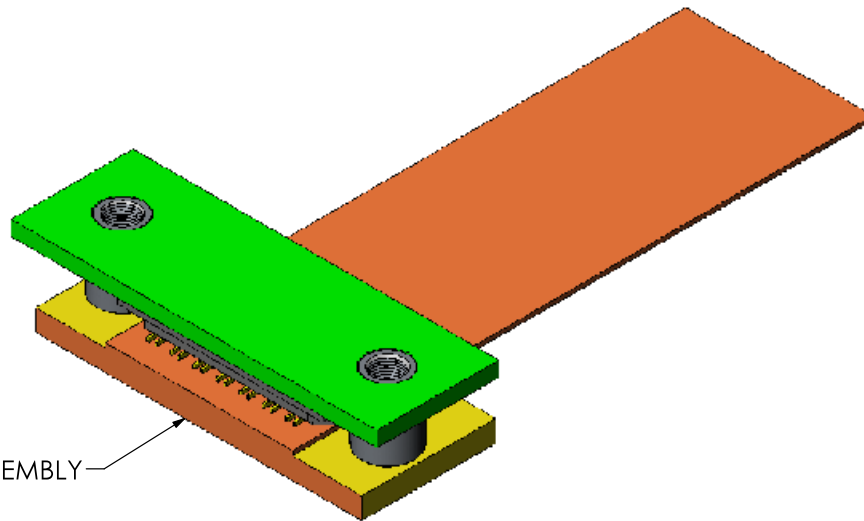

FIG. 2
-01: BOARD TO BOARD



HFEM/HFEM2 ASSEMBLY

FIG. 3
-02/-03: BOARD TO FLEX

PROPRIETARY NOTE
THIS DOCUMENT CONTAINS INFORMATION CONFIDENTIAL AND PROPRIETARY TO SAMTEC, INC. AND SHALL NOT BE REPRODUCED OR TRANSFERRED TO OTHER DOCUMENTS OR DISCLOSED TO OTHERS OR USED FOR ANY PURPOSE OTHER THAN THAT WHICH IT WAS OBTAINED WITHOUT THE EXPRESSED WRITTEN CONSENT OF SAMTEC, INC.

DO NOT SCALE DRAWING

SHEET SCALE: 1:0.555556

SAMTEC

520 PARK EAST BLVD, NEW ALBANY, IN 47150
* PHONE: 812.944.6733 FAX: 812.948.5047
e-Mail: INFO@SAMTEC.COM CODE: 55322

DESCRIPTION: QXX SERIES STANDOFF

DWG. NO. QSPR-XX

BY: CLAY W 10/17/2005 SHEET 2 OF 2