

BLOCK DIAGRAM

主功能	复用功能1	复用功能2	复用功能0	主功能	复用功能1	复用功能2	复用功能0
sdio0_clk	-	-	GPIO90	lcd_dat_g[2]	-	lioa[13]	GPIO14
sdio0_cmd	-	-	GPIO91	lcd_dat_g[3]	-	lioa[14]	GPIO15
sdio0_d[0]	can_rx[0]	uart0_rx	GPIO92	lcd_dat_g[4]	-	lioa[15]	GPIO16
sdio0_d[1]	can_tx[0]	uart0_tx	GPIO93	lcd_dat_g[5]	-	lioa[16]	GPIO17
sdio0_d[2]	can_rx[1]	uart1_rx	GPIO94	lcd_dat_g[6]	-	lioa[17]	GPIO18
sdio0_d[3]	can_tx[1]	uart1_tx	GPIO95	lcd_dat_g[7]	-	lioa[18]	GPIO19
sdio0_d[4]	can_rx[2]	uart2_tx	GPIO96	lcd_dat_r[0]	-	lioa[19]	GPIO20
sdio0_d[5]	can_tx[2]	uart2_rx	GPIO97	lcd_dat_r[1]	-	lioa[20]	GPIO21
sdio0_d[6]	can_rx[3]	uart3_tx	GPIO98	lcd_dat_r[2]	-	lioa[21]	GPIO22
sdio0_d[7]	can_tx[3]	uart3_rx	GPIO99	lcd_dat_r[3]	-	lioa[22]	GPIO23
can_rx[0]	spi0_cs[1]	uart1_dsr	GPIO68	lcd_dat_r[4]	-	liocsn[0]	GPIO24
can_tx[0]	spi0_cs[2]	uart1_dtr	GPIO69	lcd_dat_r[5]	-	liocsn[1]	GPIO25
can_rx[1]	spi0_cs[3]	uart1_dcd	GPIO70	lcd_dat_r[6]	-	liowrn	GPIO26
can_tx[1]	-	uart1_ri	GPIO71	lcd_dat_r[7]	-	liordn	GPIO27
can_rx[2]	sdio1_d[4]	gmac0_col	GPIO72	lcd_en	-	lioa[2]	GPIO03
can_tx[2]	sdio1_d[5]	gmac0_crs	GPIO73	lcd_hsync	-	lioa[1]	GPIO02
can_rx[3]	sdio1_d[6]	gmac1_col	GPIO74	lcd_vsync	-	lioa[0]	GPIO01
can_tx[3]	sdio1_d[7]	gmac1_crs	GPIO75	sdio1_clk	-	-	GPIO100
gmac0_mdck	-	-	GPIO38	sdio1_cmd	tim1_ch4	-	GPIO101
gmac0_mdio	-	-	GPIO39	sdio1_d[0]	tim2_ch4	pwm[0]	GPIO102
gmac0_rx_ctl	-	tim1_ch1	GPIO28	sdio1_d[1]	atim_etr	pwm[1]	GPIO103
gmac0_rx[0]	-	tim1_ch2	GPIO29	sdio1_d[2]	gtim_etr	pwm[2]	GPIO104
gmac0_rx[1]	-	tim1_ch3	GPIO30	sdio1_d[3]	tim1_breakin	pwm[3]	GPIO105
gmac0_rx[2]	-	tim1_ch1n	GPIO31	spi0_clk	-	can_rx[2]	GPIO56
gmac0_rx[3]	-	tim1_ch2n	GPIO32	spi0_cs[0]	-	can_tx[3]	GPIO59
gmac0_tx_ctl	-	tim1_ch3n	GPIO33	spi0_miso	-	can_tx[2]	GPIO57
gmac0_tx[0]	-	tim2_ch1	GPIO34	spi0_mosi	-	can_rx[3]	GPIO58
gmac0_tx[1]	-	tim2_ch2	GPIO35	spi1_clk	i2c_scl[0]	uart0_rts	GPIO60
gmac0_tx[2]	-	tim2_ch3	GPIO36	spi1_cs[0]	i2c_sda[1]	uart0_dtr	GPIO63
gmac0_tx[3]	-	-	GPIO37	spi1_miso	i2c_sda[0]	uart0_cts	GPIO61
i2c_scl[0]	gmac1_rx[3]	lio_data[8]	GPIO48	spi1_mosi	i2c_scl[1]	uart0_dsr	GPIO62
i2c_sda[0]	gmac1_tx_ctl	lio_data[9]	GPIO49	spi2_clk	pwm[0]	uart0_dcd	GPIO64
i2c_scl[1]	gmac1_tx[0]	lio_data[10]	GPIO50	spi2_cs	pwm[3]	uart1_cts	GPIO67
i2c_sda[1]	gmac1_tx[1]	lio_data[11]	GPIO51	spi2_miso	pwm[1]	uart0_ri	GPIO65
i2c_scl[2]	gmac1_tx[2]	lio_data[12]	GPIO52	spi2_mosi	pwm[2]	uart1_rts	GPIO66
i2c_sda[2]	gmac1_tx[3]	lio_data[13]	GPIO53	tim1_ch1	-	-	GPIO81
i2c_scl[3]	gmac1_mdck	lio_data[14]	GPIO54	tim1_ch1n	spi3_mosi	i2c_scl[3]	GPIO84
i2c_sda[3]	gmac1_mdio	lio_data[15]	GPIO55	tim1_ch2	spi3_clk	i2c_scl[2]	GPIO82
i2s_bclk	tim2_ch4	-	GPIO77	tim1_ch2n	spi3_cs	i2c_sda[3]	GPIO85
i2s_datai	gtim_etr	spi1_cs[2]	GPIO79	tim1_ch3	spi3_miso	i2c_sda[2]	GPIO83
i2s_datao	tim1_breakin	spi1_cs[3]	GPIO80	tim1_ch3n	sdio1_d[4]	pwm[0]	GPIO86
i2s_lr	atim_etr	spi1_cs[1]	GPIO78	tim2_ch1	sdio1_d[5]	pwm[1]	GPIO87
i2s_mclk	tim1_ch4	-	GPIO76	tim2_ch2	sdio1_d[6]	pwm[2]	GPIO88
lcd_clk	-	-	GPIO00	tim2_ch3	sdio1_d[7]	pwm[3]	GPIO89
lcd_dat_b[0]	-	lioa[3]	GPIO04	uart0_rx	gmac0_ptp_trig	lio_data[0]	GPIO40
lcd_dat_b[1]	-	lioa[4]	GPIO05	uart0_tx	gmac0_ptp_pps	lio_data[1]	GPIO41
lcd_dat_b[2]	-	lioa[5]	GPIO06	uart1_rx	gmac1_ptp_trig	lio_data[2]	GPIO42
lcd_dat_b[3]	-	lioa[6]	GPIO07	uart1_tx	gmac1_ptp_pps	lio_data[3]	GPIO43
lcd_dat_b[4]	-	lioa[7]	GPIO08	uart2_rx	gmac1_rx[0]	lio_data[5]	GPIO45
lcd_dat_b[5]	-	lioa[8]	GPIO09	uart2_tx	gmac1_rx_ctl	lio_data[4]	GPIO44
lcd_dat_b[6]	-	lioa[9]	GPIO10	uart3_rx	gmac1_rx[2]	lio_data[7]	GPIO47
lcd_dat_b[7]	-	lioa[10]	GPIO11	uart3_tx	gmac1_rx[1]	lio_data[6]	GPIO46
lcd_dat_g[0]	-	lioa[11]	GPIO12				
lcd_dat_g[1]	-	lioa[12]	GPIO13				

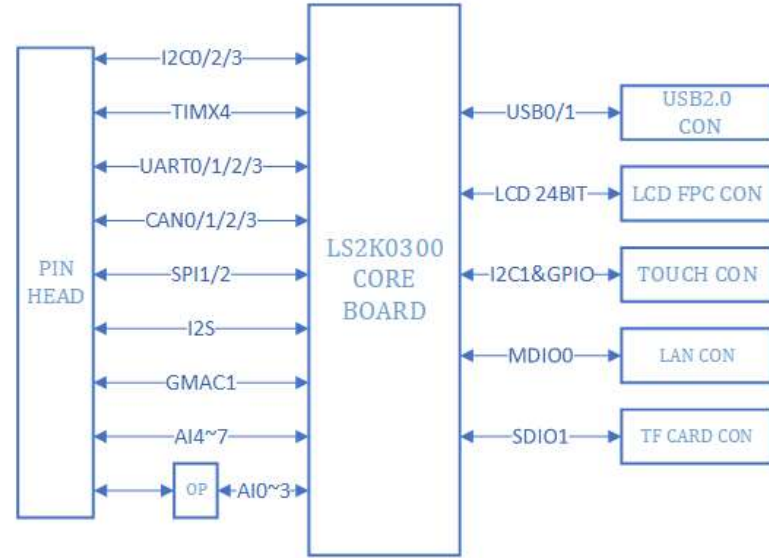

龙芯中科 龙芯中科股份有限公司 LOONGSON TECHNOLOGY			
板卡名称 GBKPAW0_V1.1			
Size B	部门	研发部	Rev 1.1
Date:	Friday, May 17, 2024		Sheet 2 of 14
Drawn By	<OrgAddr1>	Checked By	<OrgAddr2>

POWER DIAGRAM

 龙芯中科 龙芯中科科技股份有限公司 <small>LOONGSON TECHNOLOGY</small>			
板卡名称 GBKPAW0_V1.1			
Size B	部门	研发部	Rev 1.1
Date: Wednesday, June 05, 2024		Sheet 3 of 14	
Drawn By <OrgAddr1>		Checked By <OrgAddr2>	

CONNECTOR

- CPU_UART0_RXD 1
- CPU_UART0_TXD 2
- CPU_CAN0_TX 3
- CPU_CAN0_RX 4
- CPU_CAN2_TX 5
- CPU_CAN2_RX 6
- CPU_CAN3_TX 7
- CPU_CAN3_RX 8
- CPU_CAN1_TX 9
- CPU_CAN1_RX 10
- 11
- 12
- CPU_SDIO1_DATA3 13
- CPU_SDIO1_DATA2 14
- CPU_SDIO1_DATA1 15
- CPU_SDIO1_DATA0 16
- CPU_SDIO1_CMD 17
- CPU_SDIO1_CLK 18
- 19
- CPU_TIM2_CH3 20
- CPU_TIM2_CH2 21
- CPU_TIM2_CH1 22
- CPU_TIM1_CH2N 23
- CPU_TIM1_CH2 24
- CPU_TIM1_CH3N 25
- CPU_TIM1_CH3 26
- CPU_TIM1_CH1N 27
- CPU_TIM1_CH1 28
- 29
- CPU_LCD_VSYNC 30
- CPU_LCD_HSYNC 31
- CPU_LCD_EN 32
- CPU_LCD_CLK 33
- CPU_LCD_DATA0 34
- CPU_LCD_DATA1 35
- CPU_LCD_DATA2 36
- CPU_LCD_DATA3 37

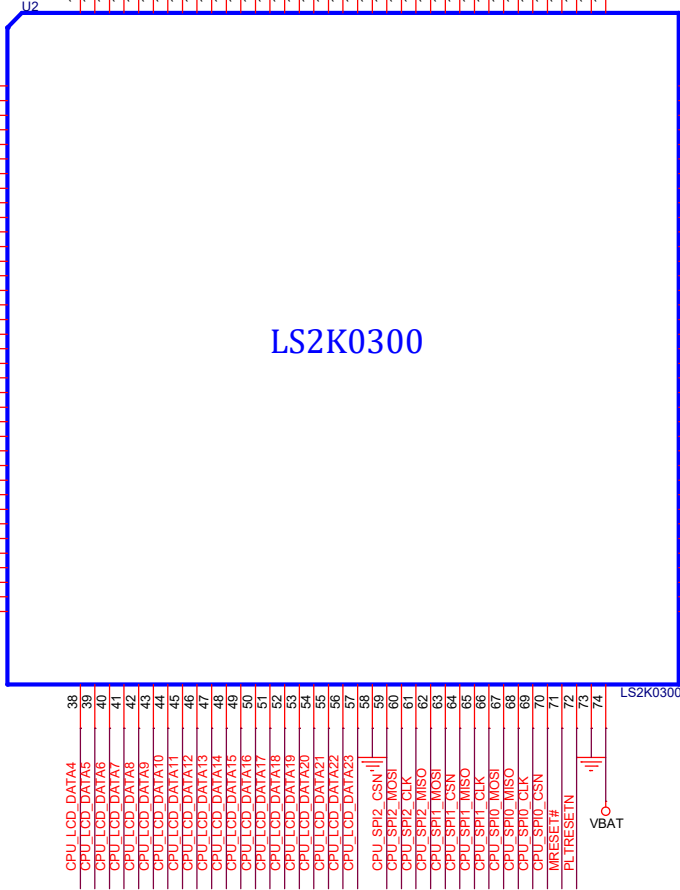

- 148 PHY0_LED0
- 147 PHY0_LED1
- 146 PHY0_LED2
- 145 P0_MDIO3+
- 144 P0_MDIO3-
- 143 P0_MDIO2+
- 142 P0_MDIO2-
- 141 P0_MDIO1+
- 140 P0_MDIO1-
- 139 P0_MDIO0+
- 138 P0_MDIO0-
- 137 CPU_GMAC1_RXCLK
- 136 CPU_GMAC1_TXCLK
- 135 CPU_GMAC1_TXCLK_O
- 134 CPU_I2C0_SCL
- 133 CPU_I2C0_SDA
- 132 CPU_UART3_TXD
- 131 CPU_UART3_RXD
- 130 CPU_UART1_TXD
- 129 CPU_UART1_RXD
- 128 CPU_UART2_TXD
- 127 CPU_UART2_RXD
- 126 CPU_I2C2_SCL
- 125 CPU_I2C2_SDA
- 124 CPU_I2C3_SCL
- 123 CPU_I2C3_SDA
- 122 CPU_I2C1_SCL
- 121 CPU_I2C1_SDA
- 120 CPU_I2S_BCLK
- 119 CPU_I2S_MCLK
- 118 CPU_I2S_DO
- 117 CPU_I2S_DI
- 116 CPU_I2S_LR
- 115 CPU_I2S_LR
- 114 MB_PWREN
- 113 MB_PWREN
- 112

- 38 CPU_LCD_DATA4
- 39 CPU_LCD_DATA5
- 40 CPU_LCD_DATA6
- 41 CPU_LCD_DATA7
- 42 CPU_LCD_DATA8
- 43 CPU_LCD_DATA9
- 44 CPU_LCD_DATA10
- 45 CPU_LCD_DATA11
- 46 CPU_LCD_DATA12
- 47 CPU_LCD_DATA13
- 48 CPU_LCD_DATA14
- 49 CPU_LCD_DATA15
- 50 CPU_LCD_DATA16
- 51 CPU_LCD_DATA17
- 52 CPU_LCD_DATA18
- 53 CPU_LCD_DATA19
- 54 CPU_LCD_DATA20
- 55 CPU_LCD_DATA21
- 56 CPU_LCD_DATA22
- 57 CPU_LCD_DATA23
- 58 CPU_SPI2_CSN
- 59 CPU_SPI2_MOSI
- 60 CPU_SPI2_CLK
- 61 CPU_SPI2_MISO
- 62 CPU_SPI1_MOSI
- 63 CPU_SPI1_CSN
- 64 CPU_SPI1_CLK
- 65 CPU_SPI1_MOSI
- 66 CPU_SPI0_MISO
- 67 CPU_SPI0_CLK
- 68 CPU_SPI0_CSN
- 69
- 70 MRESET#
- 71 PLTRESETN
- 72 MRESET#
- 73
- 74

LS2K0300

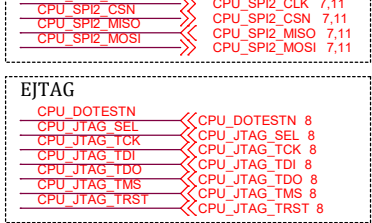
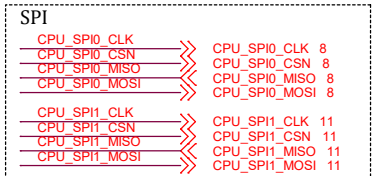
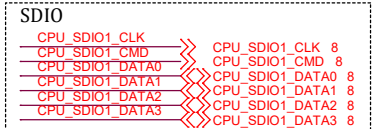
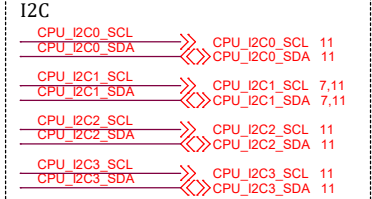
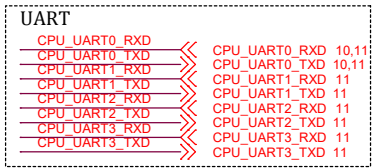
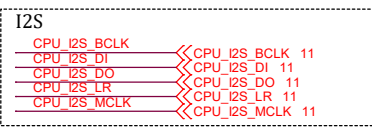
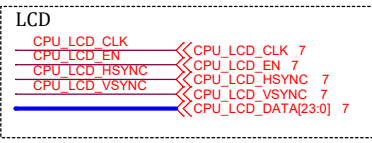
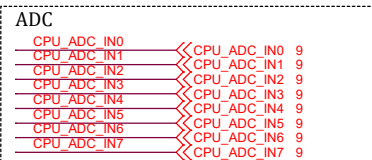
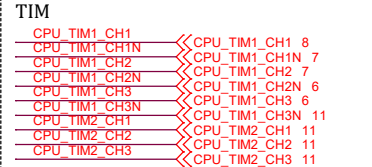
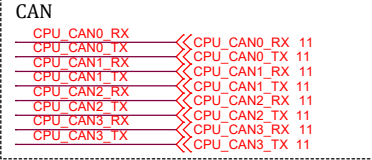
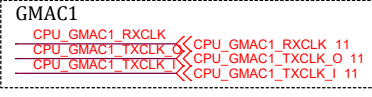
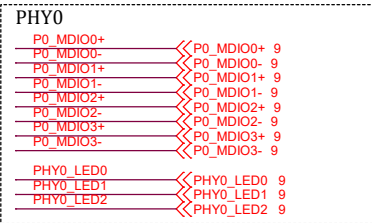
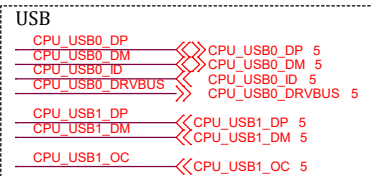

龙芯中科 龙芯中科股份有限公司

LONGSON TECHNOLOGY

板卡名称 GBKPAW0_V1.1

Size B	部门 研发部	Rev 1.1
Date: Friday, May 17, 2024		Sheet 4 of 14
Drawn By <OrgAddr1>		Checked By <OrgAddr2>

USB

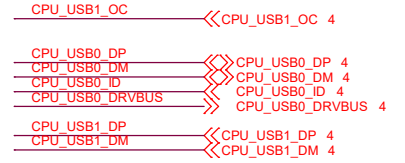
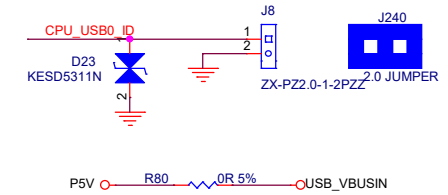
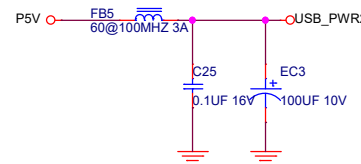
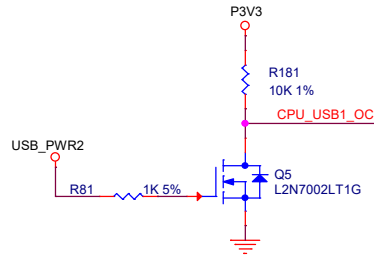
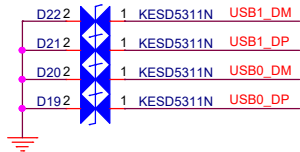
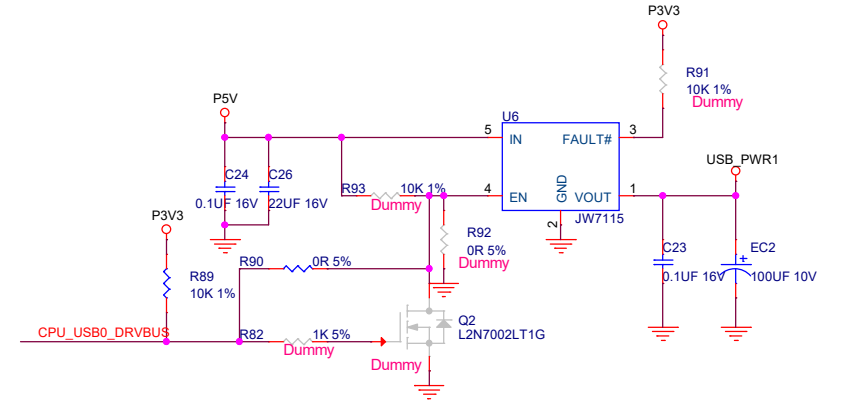
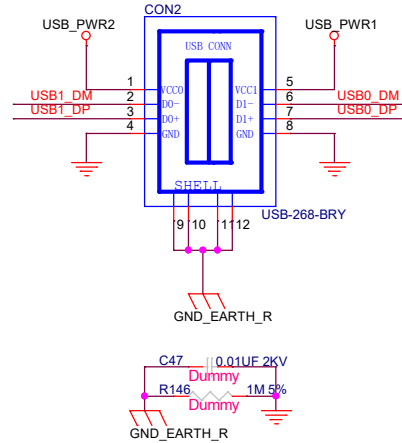
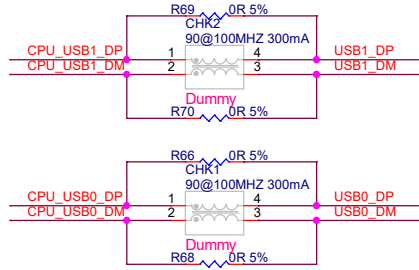

龙芯中科 龙芯中科技术股份有限公司 LONGSON TECHNOLOGY			
板卡名称 GBKPAW0_V1.1			
Size B	部门	研发部	Rev 1.1
Date: Wednesday, June 05, 2024		Sheet 5 of 14	
Drawn By <OrgAddr1>		Checked By <OrgAddr2>	

KEY&LED

CPU_TIM1_CH2N CPU_TIM1_CH3 CPU_TIM1_CH2N 4 CPU_TIM1_CH3 4

CPU_TIM1_CH2N R3 22R 5% GPIO85
CPU_TIM1_CH3 R5 22R 5% GPIO83

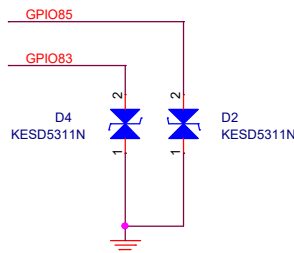
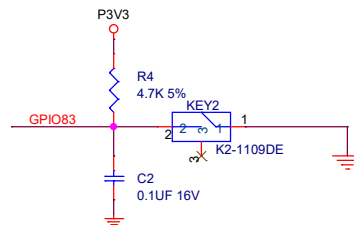
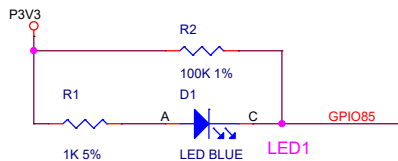

RESET

MRESET# MRESET# 4.8

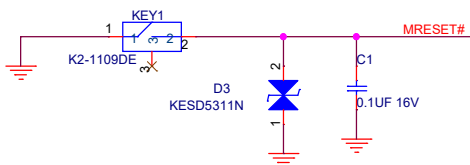

板卡名称 GBKPAW0_V1.1			
Size B	部门	研发部	Rev 1.1
Date: Friday, May 17, 2024		Sheet 6 of 14	
Drawn By <OrgAddr1>		Checked By <OrgAddr2>	

LCD PORT

CPU_LCD_DATA0	R13	22R 5%	LCD_B0
CPU_LCD_DATA1	R36	22R 5%	LCD_B1
CPU_LCD_DATA2	R11	22R 5%	LCD_B2
CPU_LCD_DATA3	R34	22R 5%	LCD_B3
CPU_LCD_DATA4	R32	22R 5%	LCD_B4
CPU_LCD_DATA5	R27	22R 5%	LCD_B5
CPU_LCD_DATA6	R30	22R 5%	LCD_B6
CPU_LCD_DATA7	R28	22R 5%	LCD_B7
CPU_LCD_DATA8	R40	22R 5%	LCD_G0
CPU_LCD_DATA9	R145	22R 5%	LCD_G1
CPU_LCD_DATA10	R31	22R 5%	LCD_G2
CPU_LCD_DATA11	R33	22R 5%	LCD_G3
CPU_LCD_DATA12	R35	22R 5%	LCD_G4
CPU_LCD_DATA13	R37	22R 5%	LCD_G5
CPU_LCD_DATA14	R39	22R 5%	LCD_G6
CPU_LCD_DATA15	R38	22R 5%	LCD_G7

CPU_LCD_DATA16	R41	22R 5%	LCD_R0
CPU_LCD_DATA17	R43	22R 5%	LCD_R1
CPU_LCD_DATA18	R45	22R 5%	LCD_R2
CPU_LCD_DATA19	R50	22R 5%	LCD_R3
CPU_LCD_DATA20	R48	22R 5%	LCD_R4
CPU_LCD_DATA21	R46	22R 5%	LCD_R5
CPU_LCD_DATA22	R44	22R 5%	LCD_R6
CPU_LCD_DATA23	R42	22R 5%	LCD_R7

CPU_LCD_EN	R14	22R 5%	LCD_DE
------------	-----	--------	--------

CPU_LCD_HSYNC	R26	22R 5%	LCD_HSYNC
CPU_LCD_VSYNC	R15	22R 5%	LCD_VSYNC

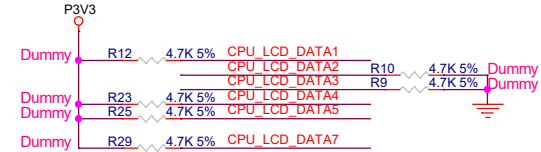
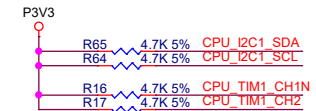
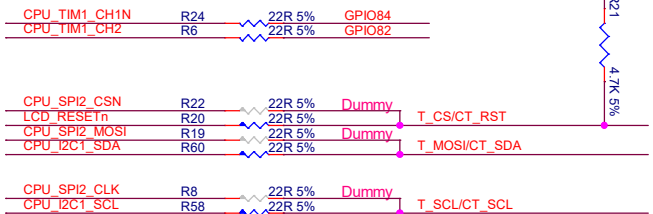
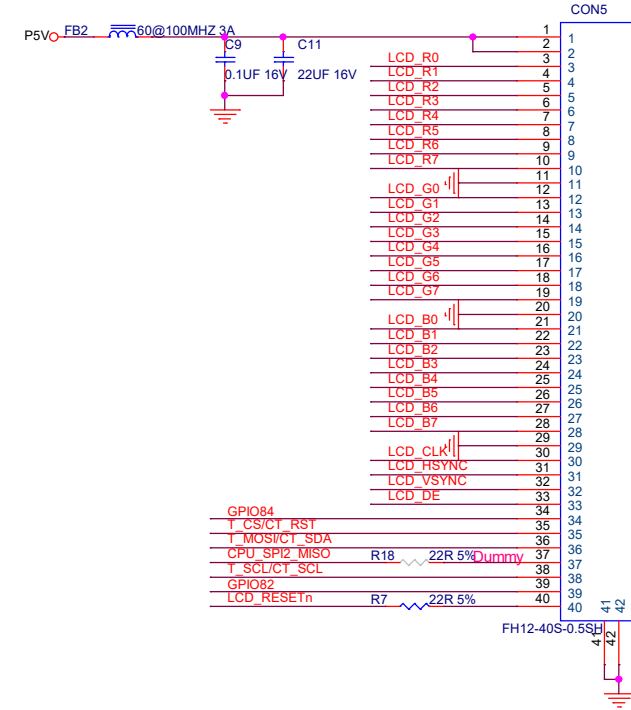
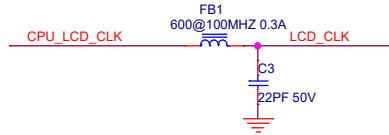

CPU_LCD_CLK	>>>	CPU_LCD_CLK	4
CPU_LCD_EN	>>>	CPU_LCD_EN	4
CPU_LCD_HSYNC	>>>	CPU_LCD_HSYNC	4
CPU_LCD_VSYNC	>>>	CPU_LCD_VSYNC	4
CPU_LCD_DATA[23:0]	>>>	CPU_LCD_DATA[23:0]	4
CPU_SPI2_CLK	>>>	CPU_SPI2_CLK	4,11
CPU_SPI2_CSN	>>>	CPU_SPI2_CSN	4,11
CPU_SPI2_MISO	>>>	CPU_SPI2_MISO	4,11
CPU_SPI2_MOSI	>>>	CPU_SPI2_MOSI	4,11
PLTRESETN	>>>	PLTRESETN	4
CPU_I2C1_SCL	>>>	CPU_I2C1_SCL	4,11
CPU_I2C1_SDA	>>>	CPU_I2C1_SDA	4,11
CPU_TIM1_CH1N	>>>	CPU_TIM1_CH1N	4
CPU_TIM1_CH2	>>>	CPU_TIM1_CH2	4

龙芯中科 龙芯中科股份有限公司
LOONGSON TECHNOLOGY

板卡名称: GBKPAW0_V1.1

Size: B	部门: 研发部	Rev: 1.1
Date: Friday, May 17, 2024		Sheet 7 of 14
Drawn By: <OrgAddr1>	Checked By: <OrgAddr2>	

EJTAG

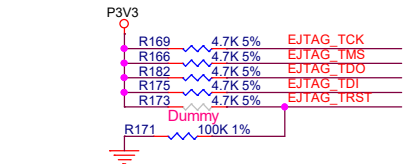
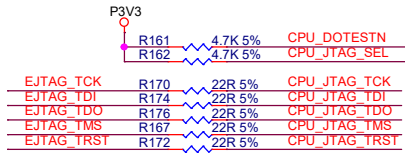
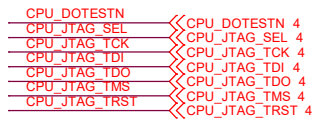

RTC

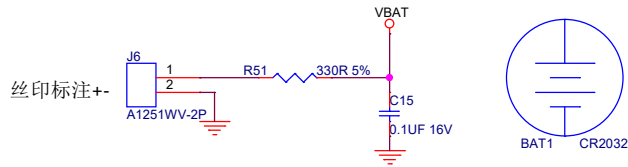

SPIO

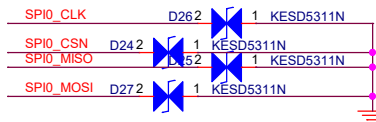
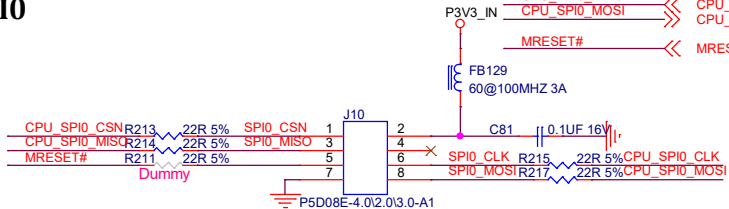
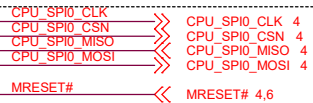

TF CARD SLOT

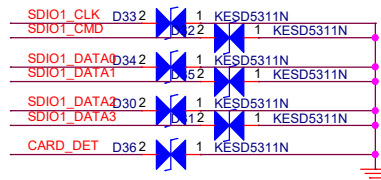
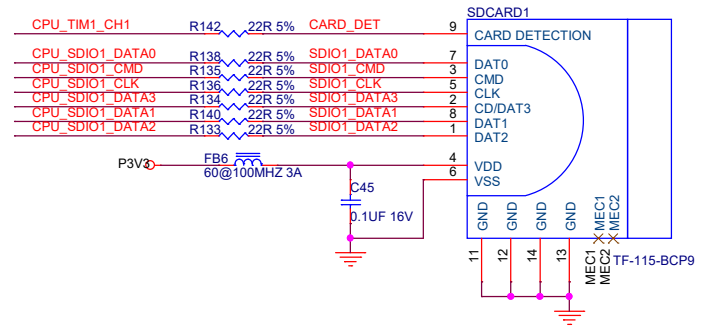
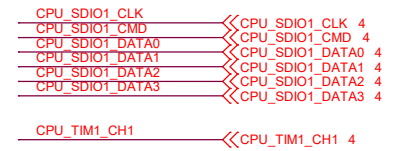

板卡名称 GBKPAW0_V1.1			
Size B	部门	研发部	Rev 1.1
Date: Wednesday, June 05, 2024		Sheet 8 of 14	
Drawn By <OrgAddr1>		Checked By <OrgAddr2>	

AI

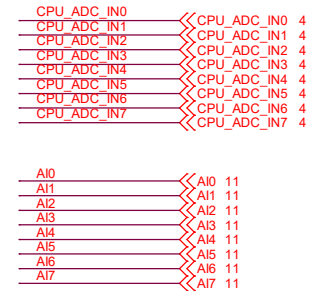
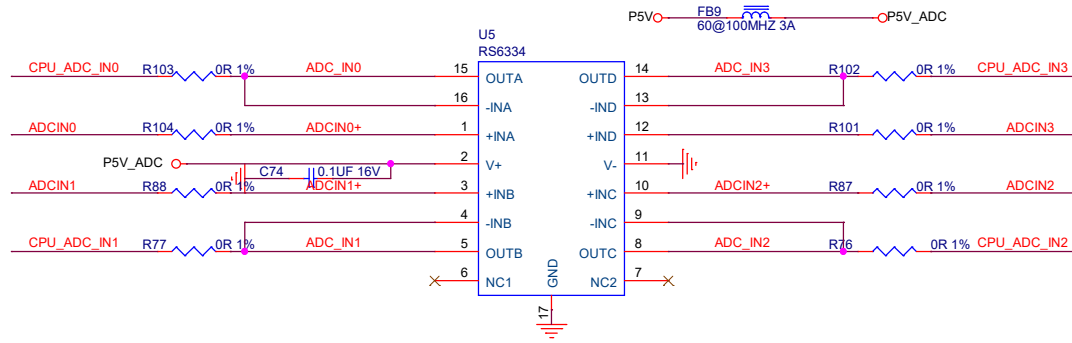

AIO~3 默认4-20MA电流检测

AI4~7 默认0~1.8V电压检测

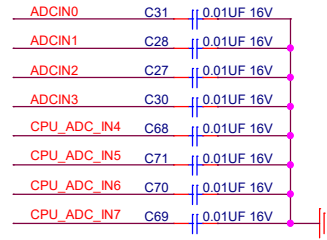
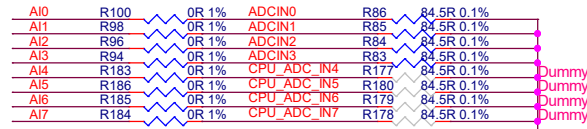

LAN

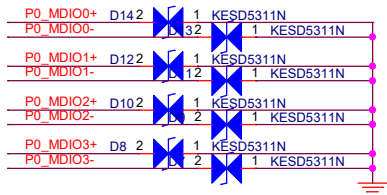
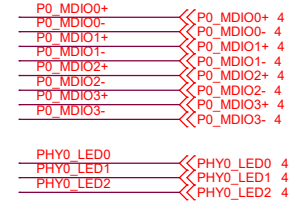
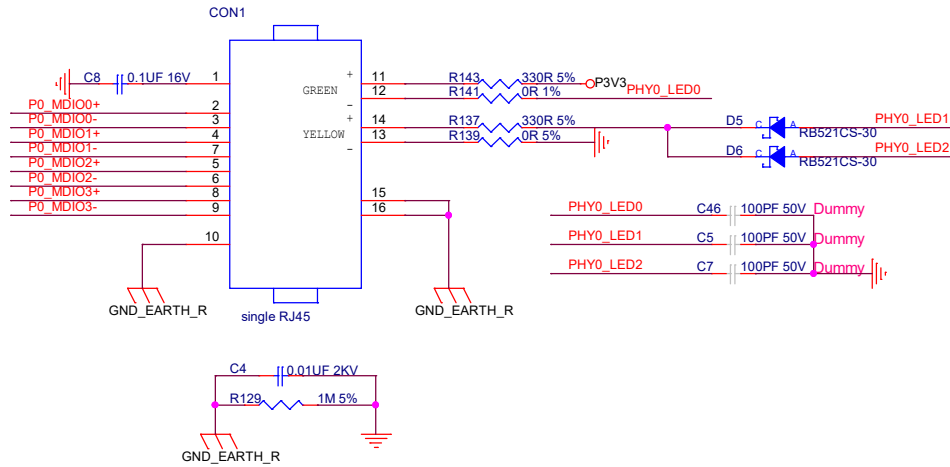

龙芯中科 龙芯中科科技股份有限公司
LOONGSON TECHNOLOGY

板卡名称 GBKPAW0_V1.1			
Size B	部门	研发部	Rev 1.1
Date: Wednesday, June 05, 2024		Sheet 9 of 14	
Drawn By <OrgAddr1>		Checked By <OrgAddr2>	

USB2UART0

CPU_UART0_TXD >>> CPU_UART0_TXD 4,11
 CPU_UART0_RXD >>> CPU_UART0_RXD 4,11

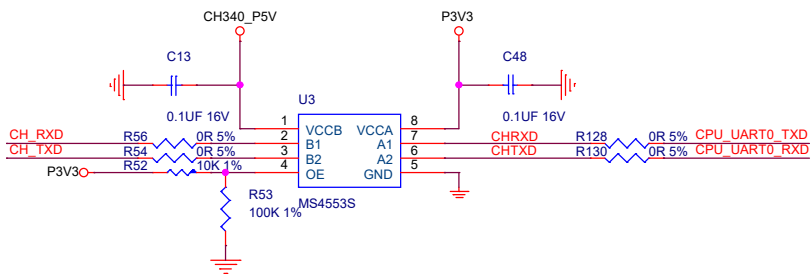
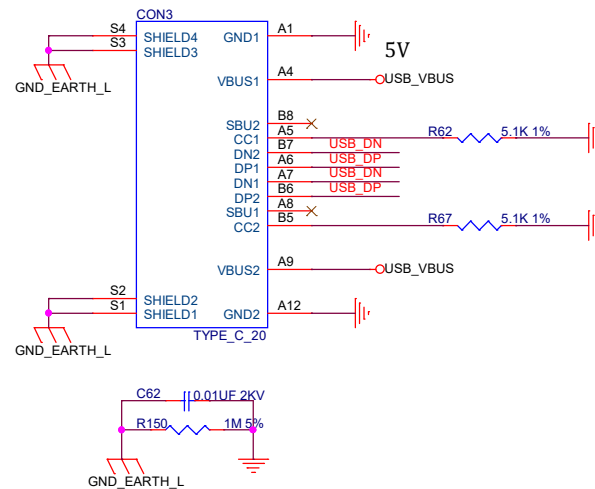
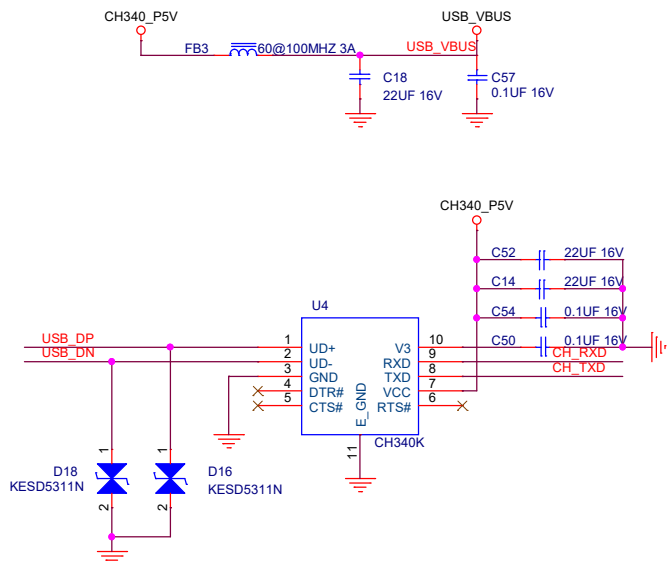

龙芯中科技术股份有限公司 LOONGSON TECHNOLOGY			
板卡名称 GBKPAW0_V1.1			
Size B	部门	研发部	Rev 1.1
Date: Wednesday, June 05, 2024		Sheet 10 of 14	
Drawn By <OrgAddr1>		Checked By <OrgAddr2>	

PIN EXTERNAL

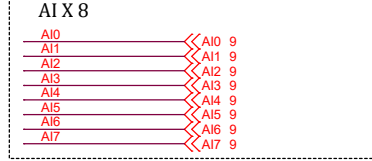
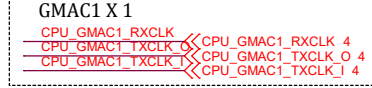
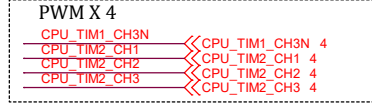
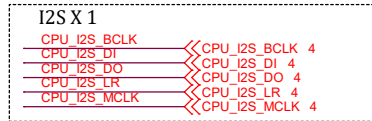
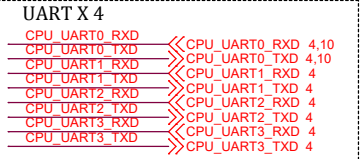
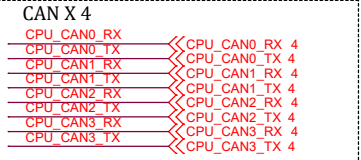
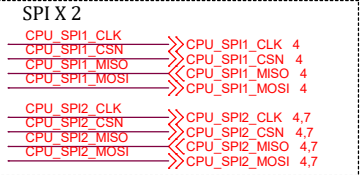
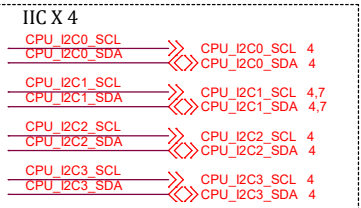
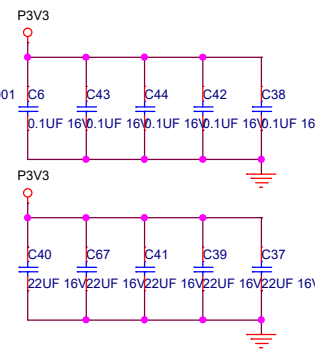
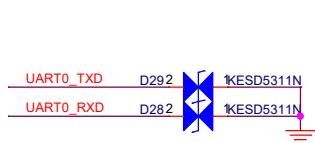
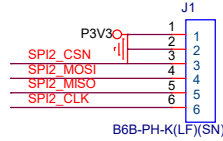
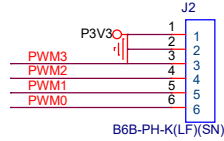
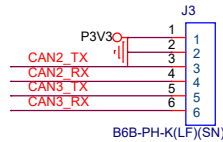
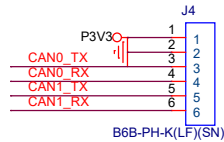
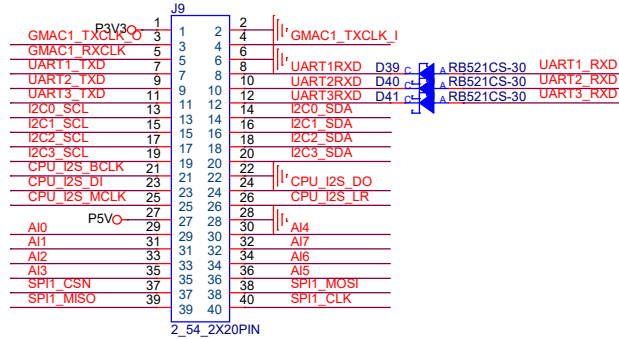
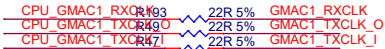
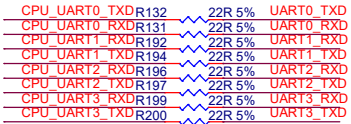
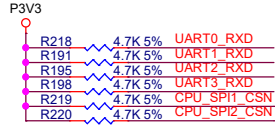
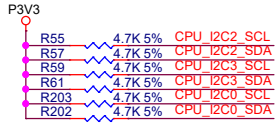

龙芯中科 龙芯中科技术股份有限公司
LOONGSON TECHNOLOGY

板卡名称 GBKPAW0_V1.1

Size B 部门 研发部 Rev 1.1

Date: Friday, May 17, 2024 Sheet 11 of 14

Drawn By <OrgAddr1> Checked By <OrgAddr2>

P3V3

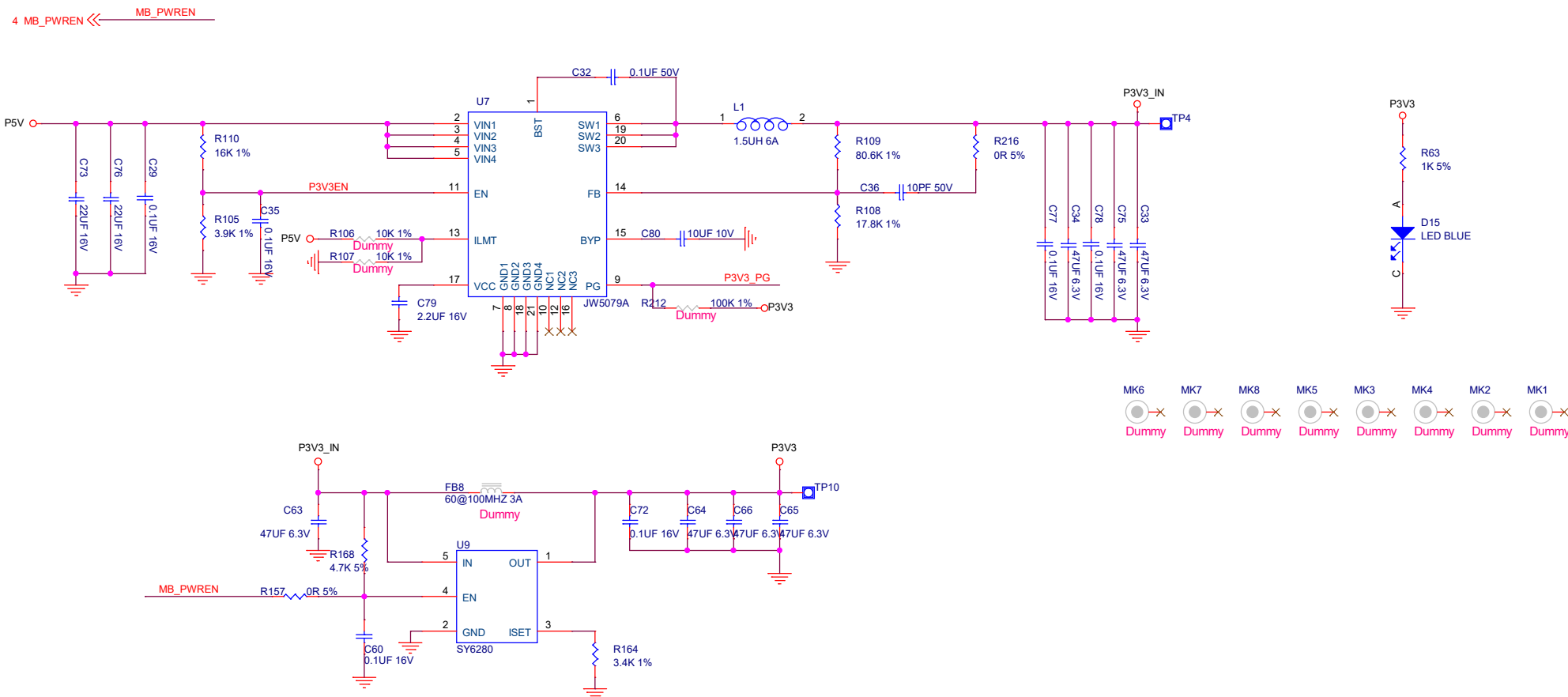

龙芯中科 龙芯中科技术有限公司
 LOONGSON TECHNOLOGY

板卡名称 GBKPAW0_V1.1			
Size B	部门 研发部	Rev 1.1	
Date: Wednesday, June 05, 2024	Sheet 13 of 14		
Drawn By <OrgAddr1>	Checked By <OrgAddr2>		