

ASMT-UWBG, ASMT-UWBH

0.25 W Cool White Power PLCC4

Surface Mount LED



Data Sheet



Description

The Avago Technologies ASMT-UWBx series 0.25W Cool White Power PLCC4 SMT LED lamps use InGaN chip technology and superior package design to enable them to produce higher light output with better flux performance. They can be driven at high current and are able to dissipate the heat more efficiently resulting in better performance with higher reliability. These lamps are able to operate under a wide range of environmental conditions making them ideal for various applications including fluorescent replacement, under cabinet lighting, retail display lighting and panel lights.

To facilitate easy pick and place assembly, the LEDs are packed in EIA-compliant tape and reel. Every reel is shipped in single intensity and color bin, to provide close uniformity.

Features

- 4000 K to 8000 K CCT
- ANSI bin
- Wide view angle 120°
- High reliability package with enhanced silicone resin encapsulation

Applications

- Fluorescent replacement
- Under cabinet lighting
- Panel lights
- Retail display lighting

CAUTION: Static sensitive device. Please observe appropriate precautions during handling and processing.

Package Drawing

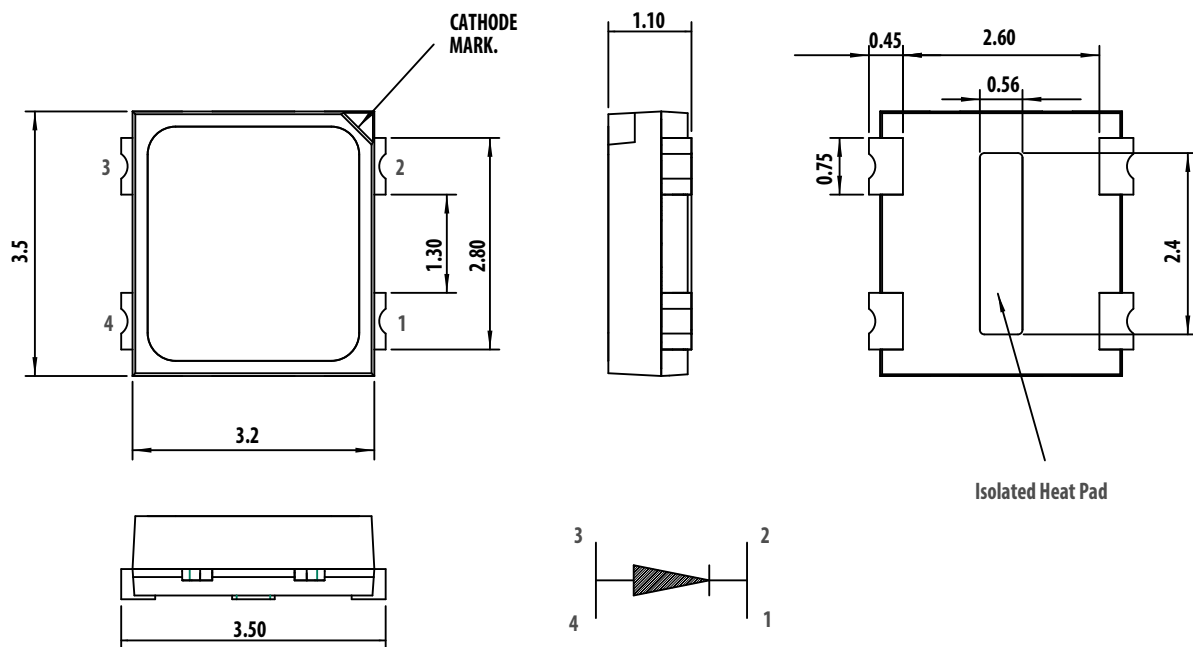

Notes:

1. Dimensions in mm.
2. Tolerance $xx.x \pm 0.2$.
3. Tolerance $xx.xx \pm 0.1$.
4. Terminal Finish: Ag plating.

Device Selection Guide

| Color | Part Number | CCT (K) | CRI | | | | Luminous Flux (lm) ^{1,2} | | Test Current (mA) | Chip |
|------------|-----------------|-------------|-----|------|------|------|-----------------------------------|-------|-------------------|------|
| | | | Typ | Min | Typ | Max | Typ | Max | | |
| Cool White | ASMT-UWBG-NAC08 | 4000 ~ 8000 | 85 | 18.1 | 19.0 | 35.2 | 80 | InGaN | | |
| Cool White | ASMT-UWBG-NACA8 | 8000 | 85 | 18.1 | 19.0 | 35.2 | 80 | InGaN | | |
| Cool White | ASMT-UWBG-NACB8 | 6500 | 85 | 18.1 | 19.0 | 35.2 | 80 | InGaN | | |
| Cool White | ASMT-UWBG-NACC8 | 5700 | 85 | 18.1 | 19.0 | 35.2 | 80 | InGaN | | |
| Cool White | ASMT-UWBG-NACD8 | 5000 | 85 | 18.1 | 19.0 | 35.2 | 80 | InGaN | | |
| Cool White | ASMT-UWBG-NACE8 | 4500 | 85 | 18.1 | 19.0 | 35.2 | 80 | InGaN | | |
| Cool White | ASMT-UWBG-NACF8 | 4000 | 85 | 18.1 | 19.0 | 35.2 | 80 | InGaN | | |
| Cool White | ASMT-UWBH-NBD08 | 4000 ~ 8000 | 75 | 23.5 | 24.7 | 39.8 | 80 | InGaN | | |
| Cool White | ASMT-UWBH-NBDA8 | 8000 | 75 | 23.5 | 24.7 | 39.8 | 80 | InGaN | | |
| Cool White | ASMT-UWBH-NBDB8 | 6500 | 75 | 23.5 | 24.7 | 39.8 | 80 | InGaN | | |
| Cool White | ASMT-UWBH-NBDC8 | 5700 | 75 | 23.5 | 24.7 | 39.8 | 80 | InGaN | | |
| Cool White | ASMT-UWBH-NBDD8 | 5000 | 75 | 23.5 | 24.7 | 39.8 | 80 | InGaN | | |
| Cool White | ASMT-UWBH-NBDE8 | 4500 | 75 | 23.5 | 24.7 | 39.8 | 80 | InGaN | | |
| Cool White | ASMT-UWBH-NBDF8 | 4000 | 75 | 23.5 | 24.7 | 39.8 | 80 | InGaN | | |

Notes:

1. Luminous flux is the total luminous flux output as measured with an integrating sphere at mono pulse conditions.
2. Tolerance $\pm 12\%$.

Part Numbering System

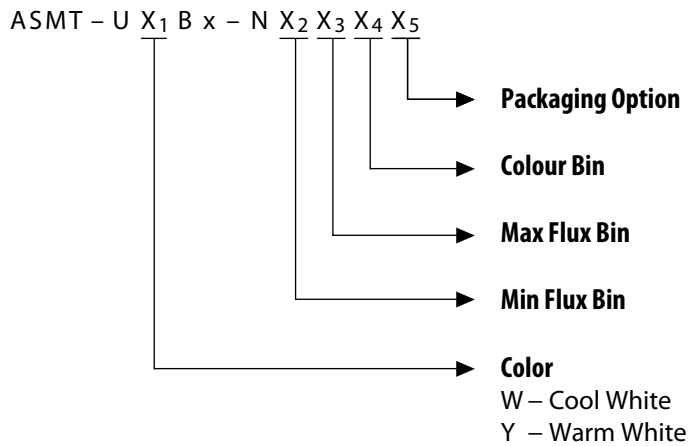

Absolute Maximum Ratings ($T_A = 25^\circ\text{C}$)

| Parameter | Rating | Unit |
|---|-----------------|------|
| DC Forward Current | 100 | mA |
| Peak Forward Current (D = 10%, f = 1 kHz) | 200 | mA |
| Power Dissipation | 360 | mW |
| Reverse Voltage | Not recommended | V |
| Junction Temperature | 125 | °C |
| Operating Temperature | -40 to 100 | °C |
| Storage Temperature | -40 to 100 | °C |

Optical / Electrical Characteristics ($T_J = 25^\circ\text{C}$)

| Parameter | Test Condition | Min | Typ | Max | Unit |
|--|----------------------|-----|-----|-----|--------|
| Viewing Angle $2\theta_{1/2}$ ¹ | | | 120 | | degree |
| Forward Voltage V_F ² | $I_F = 80\text{ mA}$ | | 3.2 | 3.4 | V |
| Thermal Resistance R_{TH} | junction to pin | | 50 | | °C/W |

Notes:

- $\theta_{1/2}$ is the off-axis angle where the luminous intensity is $\frac{1}{2}$ the peak intensity.
- Tolerance $\pm 0.1\text{ V}$.

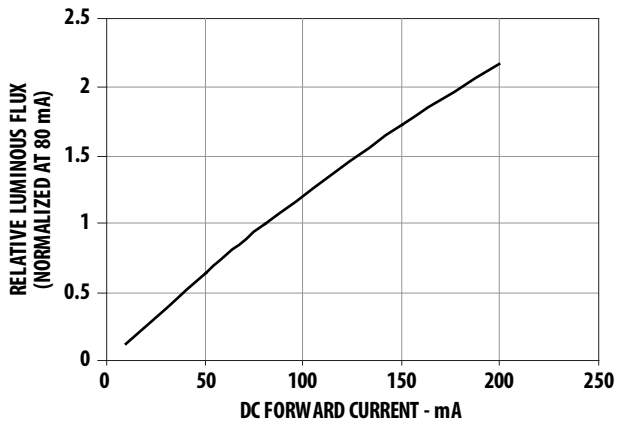

Figure 1. Relative Luminous Flux vs. Forward Current

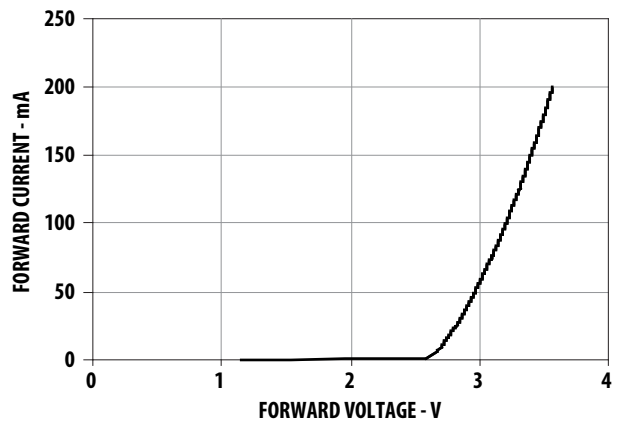

Figure 2. Forward Current vs. Forward Voltage

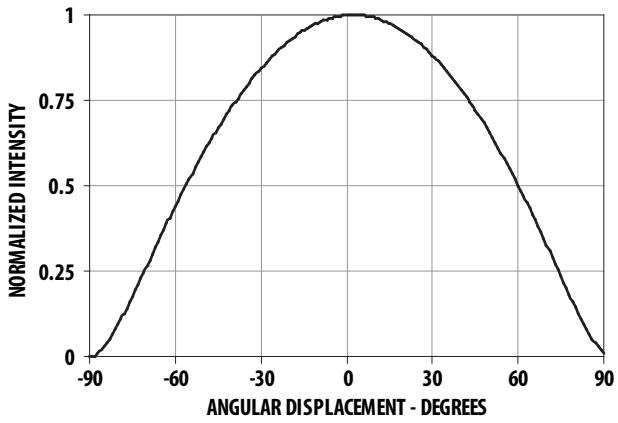

Figure 3. Radiation Diagram

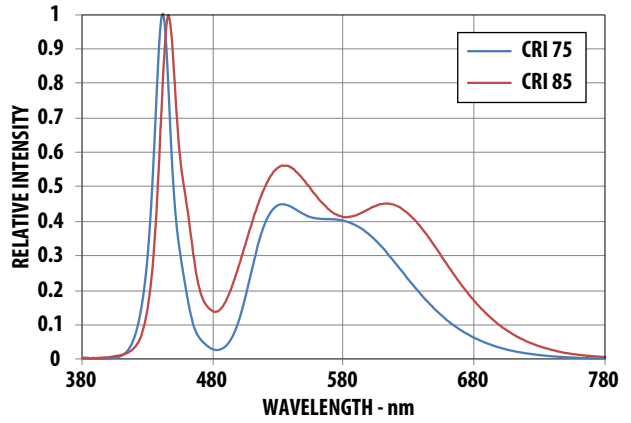

Figure 4. Spectrum Distribution

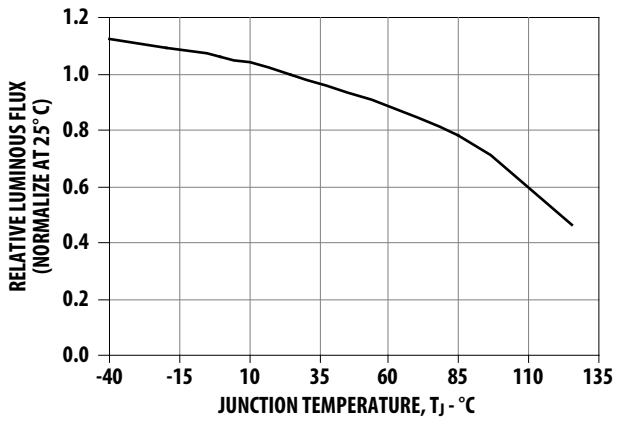

Figure 5. Relative Light Output

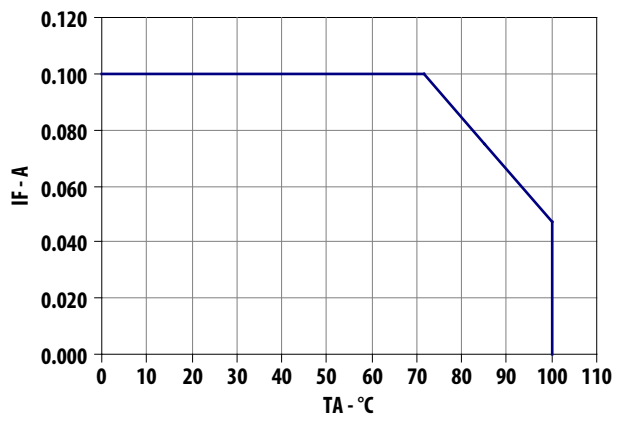

Figure 6. Forward Current Derating Curve. RTHja 140°C/W.

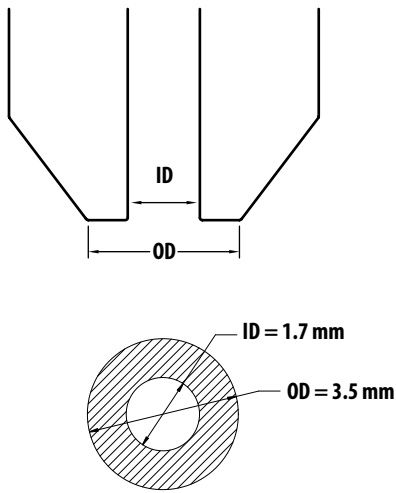

Figure 7. Recommended Pick and Place Nozzle Size

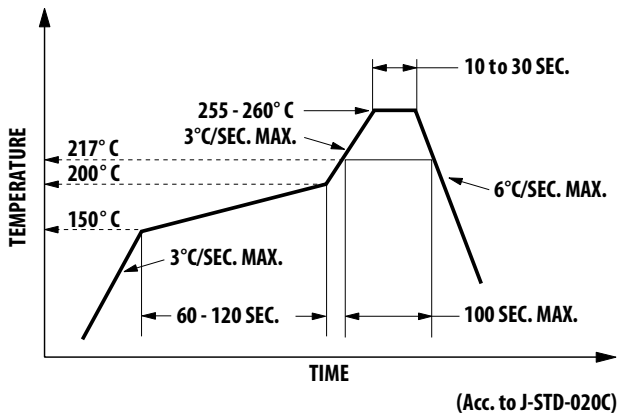

Figure 8. Recommended Pb Free Reflow Soldering Profile

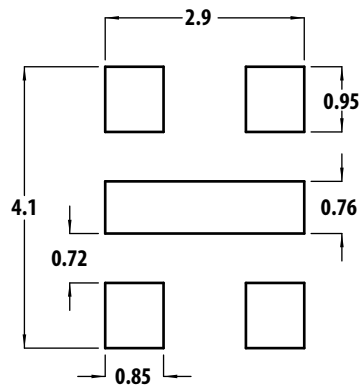

Figure 9. Recommended Solder Pad

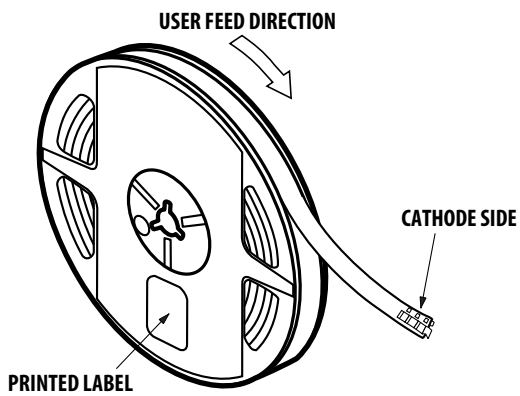

Figure 10. Reeling Orientation

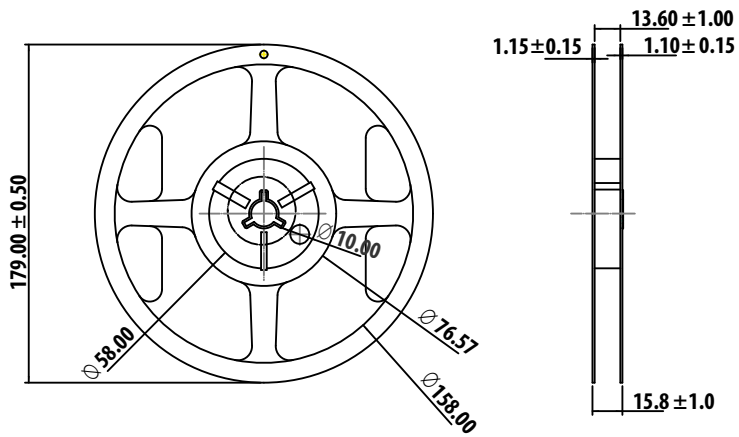

Figure 11. Reel Dimensions

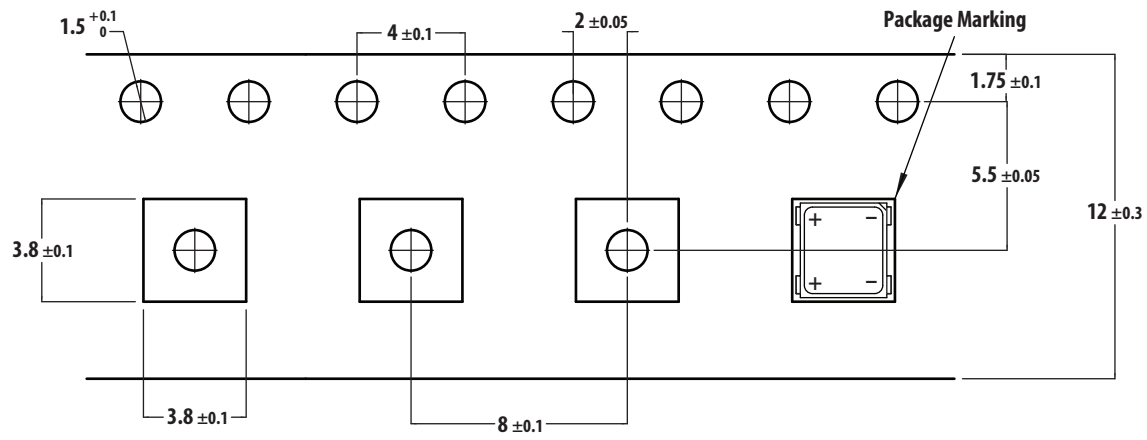

Figure 12. Carrier Tape Dimensions

Handling Precaution

The encapsulation material of the product is made of silicone for better reliability of the product. As silicone is a soft material, please do not press on the silicone or poke a sharp object onto the silicone. These might damage the product and cause premature failure. During assembly or handling, the unit should be held on the body only.

Moisture Sensitivity

This product is qualified as Moisture Sensitive Level 2 per Jedec J-STD-020. Precautions when handling this moisture sensitive product is important to ensure the reliability of the product.

A. Storage before use

- Unopen moisture barrier bag (MBB) can be stored at <40°C/90%RH for 12 months. If the actual shelf life has exceeded 12 months and the HIC indicates that baking is not required, then it is safe to reflow the LEDs per the original MSL rating.
- It is not recommended to open the MBB prior to assembly (e.g. for IQC).

B. Control after opening the MBB

- The humidity indicator card (HIC) shall be read immediately upon opening of MBB.
- The LEDs must be kept at <30°C / 60%RH at all time and all high temperature related process including soldering, curing or rework need to be completed within 1 year.

C. Control for unfinished reel

- For any unuse LEDs, they need to be stored in sealed MBB with desiccant or desiccator at <5%RH.

D. Control of assembled boards

- If the PCB soldered with the LEDs is to be subjected to other high temperature processes, the PCB need to be stored in sealed MBB with desiccant or desiccator at <5%RH to ensure no LEDs have exceeded their floor life of 1 year.

E. Baking is required if:

- 60% HIC indicator is NOT blue.
- The LEDs are exposed to condition of >30°C / 60% RH at any time.
- The LEDs floor life exceeded 1 year.

Recommended baking condition: 60±5°C for 20 hours.

Device Color (X₁)

| | |
|---|------------|
| W | Cool White |
| Y | Warm White |

Flux Bin (X₂X₃)

Individual reel will contain parts from one bin only.

| | |
|----------------|--------------|
| X ₂ | Min Flux Bin |
| X ₃ | Max Flux Bin |

| Bin | Min (lm) | Max (lm) |
|-----|----------|----------|
| A | 18.1 | 23.5 |
| B | 23.5 | 30.6 |
| C | 30.6 | 35.2 |
| D | 35.2 | 39.8 |
| E | 39.8 | 45.7 |
| F | 45.7 | 51.7 |
| G | 51.7 | 56.8 |
| H | 56.8 | 62 |
| J | 62.0 | 67.2 |
| K | 67.2 | 73.9 |

Tolerance ± 12%

Color Bin (X₄)

Individual reel will contain parts from one sub bin only.

| Bin | Sub Bin |
|-----|--|
| A | 1A, 1B, 1C, 1D |
| B | 2A, 2B, 2C, 2D |
| C | 3A, 3B, 3C, 3D |
| D | 4A, 4B, 4C, 4D |
| E | 5A, 5B, 5C, 5D |
| F | 6A, 6B, 6C, 6D |
| G | 7A, 7B, 7C, 7D |
| H | 8A, 8B, 8C, 8D |
| J | 9A, 9B, 9C, 9D |
| K | 1A, 1B, 1C, 1D, 2A, 2B, 2C, 2D |
| L | 2A, 2B, 2C, 2D, 3A, 3B, 3C, 3D |
| M | 3A, 3B, 3C, 3D, 4A, 4B, 4C, 4D |
| N | 4A, 4B, 4C, 4D, 5A, 5B, 5C, 5D |
| P | 5A, 5B, 5C, 5D, 6A, 6B, 6C, 6D |
| R | 7A, 7B, 7C, 7D, 8A, 8B, 8C, 8D |
| S | 8A, 8B, 8C, 8D, 9A, 9B, 9C, 9D |
| O | 1A, 1B, 1C, 1D, 2A, 2B, 2C, 2D, 3A, 3B, 3C, 3D, 4A, 4B, 4C, 4D, 5A, 5B, 5C, 5D, 6A, 6B, 6C, 6D |
| 1 | 7A, 7B, 7C, 7D, 8A, 8B, 8C, 8D, 9A, 9B, 9C, 9D |

| Sub Bin | Chromaticity Coordinates | | | | |
|---------|--------------------------|--------|--------|--------|--------|
| 1A | x | 0.2950 | 0.2920 | 0.2984 | 0.3009 |
| | y | 0.2970 | 0.3060 | 0.3133 | 0.3042 |
| 1B | x | 0.2920 | 0.2895 | 0.2962 | 0.2984 |
| | y | 0.3060 | 0.3135 | 0.3220 | 0.3133 |
| 1C | x | 0.2984 | 0.2962 | 0.3028 | 0.3048 |
| | y | 0.3133 | 0.3220 | 0.3304 | 0.3207 |
| 1D | x | 0.2984 | 0.3048 | 0.3068 | 0.3009 |
| | y | 0.3133 | 0.3207 | 0.3113 | 0.3042 |
| 2A | x | 0.3048 | 0.3130 | 0.3144 | 0.3068 |
| | y | 0.3207 | 0.3290 | 0.3186 | 0.3113 |
| 2B | x | 0.3028 | 0.3115 | 0.3130 | 0.3048 |
| | y | 0.3304 | 0.3391 | 0.3290 | 0.3207 |
| 2C | x | 0.3115 | 0.3205 | 0.3213 | 0.3130 |
| | y | 0.3391 | 0.3481 | 0.3373 | 0.3290 |
| 2D | x | 0.3130 | 0.3213 | 0.3221 | 0.3144 |
| | y | 0.3290 | 0.3373 | 0.3261 | 0.3186 |
| 3A | x | 0.3215 | 0.3290 | 0.3290 | 0.3222 |
| | y | 0.3350 | 0.3417 | 0.3300 | 0.3243 |
| 3B | x | 0.3207 | 0.3290 | 0.3290 | 0.3215 |
| | y | 0.3462 | 0.3538 | 0.3417 | 0.3350 |
| 3C | x | 0.3290 | 0.3376 | 0.3371 | 0.3290 |
| | y | 0.3538 | 0.3616 | 0.3490 | 0.3417 |
| 3D | x | 0.3290 | 0.3371 | 0.3366 | 0.3290 |
| | y | 0.3417 | 0.3490 | 0.3369 | 0.3300 |

Color Bin (X₄) (continued)

| Sub Bin | Chromaticity Coordinates | | | | |
|----------------|---------------------------------|--------|--------|--------|--------|
| 4A | x | 0.3371 | 0.3451 | 0.3440 | 0.3366 |
| | y | 0.3490 | 0.3554 | 0.3427 | 0.3369 |
| 4B | x | 0.3376 | 0.3463 | 0.3451 | 0.3371 |
| | y | 0.3616 | 0.3687 | 0.3554 | 0.3490 |
| 4C | x | 0.3463 | 0.3551 | 0.3533 | 0.3451 |
| | y | 0.3687 | 0.3760 | 0.3620 | 0.3554 |
| 4D | x | 0.3451 | 0.3533 | 0.3515 | 0.3440 |
| | y | 0.3554 | 0.3620 | 0.3487 | 0.3427 |
| 5A | x | 0.3530 | 0.3615 | 0.3590 | 0.3512 |
| | y | 0.3597 | 0.3659 | 0.3521 | 0.3465 |
| 5B | x | 0.3548 | 0.3641 | 0.3615 | 0.3530 |
| | y | 0.3736 | 0.3804 | 0.3659 | 0.3597 |
| 5C | x | 0.3641 | 0.3736 | 0.3702 | 0.3615 |
| | y | 0.3804 | 0.3874 | 0.3722 | 0.3659 |
| 5D | x | 0.3615 | 0.3702 | 0.3670 | 0.3590 |
| | y | 0.3659 | 0.3722 | 0.3578 | 0.3521 |
| 6A | x | 0.3670 | 0.3702 | 0.3825 | 0.3783 |
| | y | 0.3578 | 0.3722 | 0.3798 | 0.3646 |
| 6B | x | 0.3702 | 0.3736 | 0.3869 | 0.3825 |
| | y | 0.3722 | 0.3874 | 0.3958 | 0.3798 |
| 6C | x | 0.3825 | 0.3869 | 0.4006 | 0.3950 |
| | y | 0.3798 | 0.3958 | 0.4044 | 0.3875 |
| 6D | x | 0.3783 | 0.3825 | 0.3950 | 0.3898 |
| | y | 0.3646 | 0.3798 | 0.3875 | 0.3716 |
| 7A | x | 0.3889 | 0.3941 | 0.4080 | 0.4017 |
| | y | 0.3690 | 0.3848 | 0.3916 | 0.3751 |
| 7B | x | 0.3941 | 0.3996 | 0.4146 | 0.4080 |
| | y | 0.3848 | 0.4015 | 0.4089 | 0.3916 |
| 7C | x | 0.4080 | 0.4146 | 0.4299 | 0.4221 |
| | y | 0.3916 | 0.4089 | 0.4165 | 0.3984 |
| 7D | x | 0.4017 | 0.4080 | 0.4221 | 0.4147 |
| | y | 0.3751 | 0.3916 | 0.3984 | 0.3814 |
| 8A | x | 0.4147 | 0.4221 | 0.4342 | 0.4259 |
| | y | 0.3814 | 0.3984 | 0.4028 | 0.3853 |
| 8B | x | 0.4221 | 0.4299 | 0.4430 | 0.4342 |
| | y | 0.3984 | 0.4165 | 0.4212 | 0.4028 |
| 8C | x | 0.4342 | 0.4430 | 0.4562 | 0.4465 |
| | y | 0.4028 | 0.4212 | 0.4260 | 0.4071 |
| 8D | x | 0.4259 | 0.4342 | 0.4465 | 0.4373 |
| | y | 0.3853 | 0.4028 | 0.4071 | 0.3893 |
| 9A | x | 0.4373 | 0.4465 | 0.4582 | 0.4483 |
| | y | 0.3893 | 0.4071 | 0.4099 | 0.3919 |
| 9B | x | 0.4465 | 0.4562 | 0.4687 | 0.4582 |
| | y | 0.4071 | 0.4260 | 0.4289 | 0.4099 |
| 9C | x | 0.4582 | 0.4687 | 0.4813 | 0.4700 |
| | y | 0.4099 | 0.4289 | 0.4319 | 0.4126 |
| 9D | x | 0.4483 | 0.4582 | 0.4700 | 0.4593 |
| | y | 0.3919 | 0.4099 | 0.4126 | 0.3944 |

Tolerance ±0.01

Color Bin

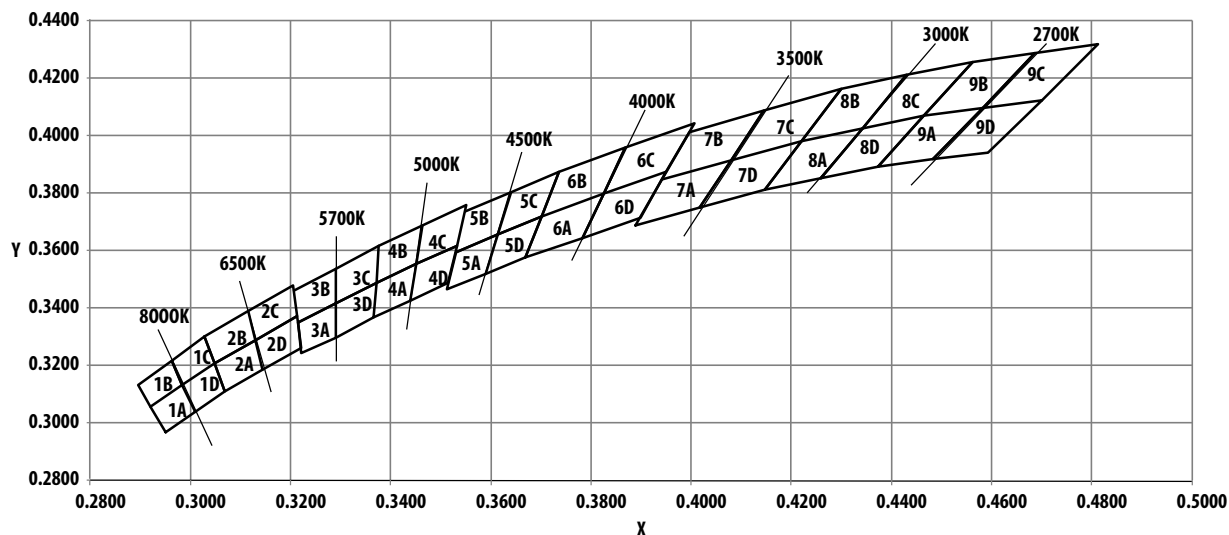

Figure 13. Color Bin

Packaging Option (X₅)

| Option | Test Current | Package Type | Reel Size |
|--------|--------------|--------------|-----------|
| 8 | 80 mA | Top Mount | 7 Inch |

Forward Voltage Bin

| Bin | Min (V) | Max (V) |
|-----|---------|---------|
| F05 | 2.8 | 3.0 |
| F06 | 3.0 | 3.2 |
| F07 | 3.2 | 3.4 |

Tolerance ± 0.1 V

DISCLAIMER: Avago's products and software are not specifically designed, manufactured or authorized for sale as parts, components or assemblies for the planning, construction, maintenance or direct operation of a nuclear facility or for use in medical devices or applications. Customer is solely responsible, and waives all rights to make claims against avago or its suppliers, for all loss, damage, expense or liability in connection with such use.

For product information and a complete list of distributors, please go to our web site: www.avagotech.com

Avago, Avago Technologies, and the A logo are trademarks of Avago Technologies in the United States and other countries. Data subject to change. Copyright © 2005-2014 Avago Technologies. All rights reserved.
AV02-3369EN - February 18, 2014

Avago
TECHNOLOGIES