

T-1³/₄ (5 mm) Precision Optical Performance AlInGaP LED Lamps

Technical Data



SunPower Series
HLMP-ELxx
HLMP-EJxx
HLMP-EHxx
HLMP-EGxx

Features

- **Well Defined Spatial Radiation Patterns**
- **Viewing Angles:** 6°, 15°, 23°, 30°
- **High Luminous Output**
- **Colors:**
 - 590 nm Amber
 - 605 nm Orange
 - 615 nm Reddish-Orange
 - 626 nm Red
- **High Operating Temperature:**
 $T_{jLED} = +130^{\circ}\text{C}$
- **Superior Resistance to Moisture**
- **Package Options:**
With or Without Lead Stand-Offs

Benefits

- **Viewing Angles Match Traffic Management Sign Requirements**
- **Colors Meet Automotive and Pedestrian Signal Specifications**
- **Superior Performance in Outdoor Environments**
- **Suitable for Autoinsertion onto PC Boards**

Applications

- **Traffic Management:**
 - Traffic Signals
 - Pedestrian Signals
 - Work Zone Warning Lights
 - Variable Message Signs
- **Commercial Outdoor Advertising:**
 - Signs
 - Marquees
- **Automotive:**
 - Exterior and Interior Lights

Description

These Precision Optical Performance AlInGaP LEDs provide superior light output for excellent readability in sunlight and are extremely reliable. AlInGaP LED technology provides extremely stable light output over long periods of time. Precision Optical Performance lamps utilize the aluminum indium gallium phosphide (AlInGaP) technology.

These LED lamps are untinted, nondiffused, T-1³/₄ packages incorporating second generation optics producing well defined spatial radiation patterns at specific viewing cone angles.

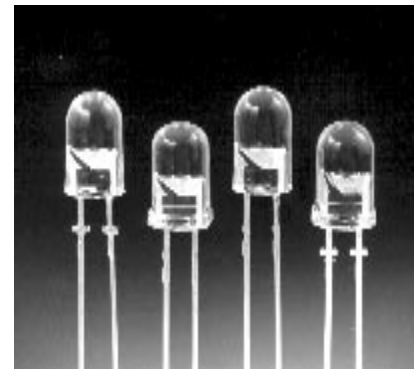

These lamps are made with an advanced optical grade epoxy, offering superior high temperature and high moisture resistance performance in outdoor signal and sign applications. The high maximum LED junction temperature limit of +130°C enables high temperature operation in bright sunlight conditions. The package epoxy contains both uv-a and uv-b inhibitors to reduce the effects of long term exposure to direct sunlight.

These lamps are available in two package options to give the designer flexibility with device mounting.

Part Numbering Scheme

HLMP-E(1)(2)(3)-

(4)(5)(6)(7)(8)

where (1) = Color

“L” = 592 nm Amber

“J” = 605 nm Orange

“H” = 615 nm Reddish-orange

“G” = 626 nm Red

where (2)(3) = Viewing

Angle and Lead Standoffs

“08” = 6 degree without lead standoffs

“10” = 6 degree with lead standoffs

“15” = 15 degree without lead standoffs

“17” = 15 degree with lead standoffs

“24” = 23 degree without lead standoffs

“26” = 23 degree with lead standoffs

“30” = 30 degree without lead standoffs

“32” = 30 degree with lead standoffs

where (4) = Minimum Intensity Bin (refer to table on page 9)

where (5) = Maximum Intensity Bin (refer to table on page 9)

where (6) = Color Bin Selection

“0” = no color bin limitation

“K” = amber color bins 2 and 4 only (refer to table on page 9)

“4” = amber color bin 4 only (refer to table on page 9)

where (7)(8) = Mechanical or Packaging Option

“00” = bulk packaging, minimum increment 500/bag

“DD” = ammo pack, minimum increment 2000/box. Available for products shown in **BOLD** in selection guide.

Refer to the device selection guides for available combinations.

Device Selection Guide

Typical Viewing Angle $2\theta_{1/2}$ (Deg.) ^[4]	Color and Dominant Wavelength (nm), Typ. ^[3]	Lamps Without Standoffs on Leads (Outline Drawing A)	Lamps With Standoffs on Leads (Outline Drawing B)	Luminous Intensity I_v (mcd) ^[1,2] @ 20 mA	
				Min.	Max.
6° ^[5]	Amber 590	HLMP-EL08-VY000	HLMP-EL10-VY000	3600	13800
		HLMP-EL08-WZ000	HLMP-EL10-WZ000	4700	18400
		HLMP-EL08-XZ400**		6200	18400
		HLMP-EL08-XZ000		6200	18400
		HLMP-EL08-XZK00*		6200	18400
		HLMP-EL08-XY000		6200	13800
		HLMP-EL08-XYK00*		6200	13800
		HLMP-EL08-X1K00*		6200	24100
		HLMP-EL08-X1000	HLMP-EL10-X1000	6200	24100

Notes:

1. The luminous intensity is measured on the mechanical axis of the lamp package.
2. The optical axis is closely aligned with the package mechanical axis.
3. The dominant wavelength, λ_d , is derived from the CIE Chromaticity Diagram and represents the color of the lamp.
4. $\theta_{1/2}$ is the off-axis angle where the luminous intensity is one half the on-axis intensity.
5. The intensity of narrow viewing angle lamps is measured at the intensity peak.

Part numbers in **bold** are recommended for new designs.

*HLMP-xLxx-xxK00 are selected to amber color bins 2 and 4 only.

**HLMP-xLxx-xx400 are selected to amber color bin 4 only.

Device Selection Guide (Continued)

Typical Viewing Angle $2\theta_{1/2}$ (Deg.) ^[4]	Color and Dominant Wavelength (nm), Typ. ^[3]	Lamps Without Standoffs on Leads (Outline Drawing A)	Lamps With Standoffs on Leads (Outline Drawing B)	Luminous Intensity I_v (mcd) ^[1,2] @ 20 mA	
				Min.	Max.
6° ^[5]	Orange 605	HLMP-EJ08-WZ000	HLMP-EJ10-WZ000	4700	18400
		HLMP-EJ08-X1000	HLMP-EJ10-X1000	6200	24100
		HLMP-EJ08-Y2000	HLMP-EJ10-Y2000	8000	31000
	Red-Orange 615	HLMP-EH08-WZ000	HLMP-EH10-WZ000	4700	18400
		HLMP-EH08-X1000	HLMP-EH10-X1000	6200	24100
		HLMP-EH08-Y2000	HLMP-EH10-Y2000	8000	31000
	Red 626	HLMP-EG08-WZ000	HLMP-EG10-WZ000	4700	18400
		HLMP-EG08-X1000	HLMP-EG10-X1000	6200	24100
		HLMP-EG08-YZ000		8000	18400
		HLMP-EG08-Y1000		8000	24100
		HLMP-EG08-Y2000	HLMP-EG10-Y2000	8000	31000
	15°	Amber 590	HLMP-EL15-PS000	HLMP-EL17-PS000	765
HLMP-EL15-QR000				1000	2200
HLMP-EL15-QRK00*				1000	2200
HLMP-EL15-QS000				1000	2900
HLMP-EL15-QS400**				1000	2900
HLMP-EL15-QSK00*				1000	2900
HLMP-EL15-QT000			HLMP-EL17-QT000	1000	3700
HLMP-EL15-QTK00*				1000	3700
HLMP-EL15-RU000			HLMP-EL17-RU000	1300	4800
HLMP-EL15-SV000			HLMP-EL17-SV000	1650	6300
Orange 605		HLMP-EJ15-RU000	HLMP-EJ17-RU000	1300	4800
		HLMP-EJ15-SV000	HLMP-EJ17-SV000	1650	6300
		HLMP-EJ15-TW000	HLMP-EJ17-TW000	2170	8300

Notes:

1. The luminous intensity is measured on the mechanical axis of the lamp package.
2. The optical axis is closely aligned with the package mechanical axis.
3. The dominant wavelength, λ_d , is derived from the CIE Chromaticity Diagram and represents the color of the lamp.
4. $\theta_{1/2}$ is the off-axis angle where the luminous intensity is one half the on-axis intensity.
5. The intensity of narrow viewing angle lamps is measured at the intensity peak.

Part numbers in **bold** are recommended for new designs.

*HLMP-xLxx-xxK00 are selected to amber color bins 2 and 4 only.

**HLMP-xLxx-xx400 are selected to amber color bin 4 only.

Device Selection Guide (Continued)

Typical Viewing Angle $2\theta_{1/2}$ (Deg.) ^[4]	Color and Dominant Wavelength (nm), Typ. ^[3]	Lamps Without Standoffs on Leads (Outline Drawing A)	Lamps With Standoffs on Leads (Outline Drawing B)	Luminous Intensity I_v (mcd) ^[1,2] @ 20 mA	
				Min.	Max.
15°	Red-Orange 615	HLMP-EH15-QT000	HLMP-EH17-QT000	1000	3700
		HLMP-EH15-RU000	HLMP-EH17-RU000	1300	4800
		HLMP-EH15-SV000	HLMP-EH17-SV000	1650	6300
	Red 626	HLMP-EG15-QT000	HLMP-EG17-QT000	1000	3700
		HLMP-EG15-RU000	HLMP-EG17-RU000	1300	4800
		HLMP-EG15-SV000	HLMP-EG17-SV000	1650	6300
23°	Amber 590	HLMP-EL24-NR000	HLMP-EL26-NR000	590	2200
		HLMP-EL24-PS000	HLMP-EL26-PS000	765	2900
		HLMP-EL24-QR000		1000	2200
		HLMP-EL24-QRK00*		1000	2200
		HLMP-EL24-QS000		1000	2900
		HLMP-EL24-QSK00*		1000	2900
		HLMP-EL24-QS400**		1000	2900
		HLMP-EL24-QT000	HLMP-EL26-QT000	1000	3700
		HLMP-EL24-QTK00*		1000	3700
	Orange 605	HLMP-EJ24-QT000	HLMP-EJ26-QT000	1000	3700
		HLMP-EJ24-RU000	HLMP-EJ26-RU000	1300	4800
		HLMP-EJ24-SV000	HLMP-EJ26-SV000	1650	6300
	Red-Orange 615	HLMP-EH24-PS000	HLMP-EH26-PS000	765	2900
		HLMP-EH24-QT000	HLMP-EH26-QT000	1000	3700
		HLMP-EH24-RU000	HLMP-EH26-RU000	1300	4800
	Red 626	HLMP-EG24-PS000	HLMP-EG26-PS000	765	2900
		HLMP-EG24-QT000	HLMP-EG26-QT000	1000	3700
		HLMP-EG24-RU000	HLMP-EG26-RU000	1300	4800

Notes:

1. The luminous intensity is measured on the mechanical axis of the lamp package.
2. The optical axis is closely aligned with the package mechanical axis.
3. The dominant wavelength, λ_d , is derived from the CIE Chromaticity Diagram and represents the color of the lamp.
4. $\theta_{1/2}$ is the off-axis angle where the luminous intensity is one half the on-axis intensity.
5. The intensity of narrow viewing angle lamps is measured at the intensity peak.

Part numbers in **bold** are recommended for new designs.

*HLMP-xLxx-xxK00 are selected to amber color bins 2 and 4 only.

**HLMP-xLxx-xx400 are selected to amber color bin 4 only.

Device Selection Guide (Continued)

Typical Viewing Angle $2\theta_{1/2}$ (Deg.) ^[4]	Color and Dominant Wavelength (nm), Typ. ^[3]	Lamps Without Standoffs on Leads (Outline Drawing A)	Lamps With Standoffs on Leads (Outline Drawing B)	Luminous Intensity I_v (mcd) ^[1,2] @ 20 mA	
				Min.	Max.
30°	Amber 590	HLMP-EL30-MQ000	HLMP-EL32-MQ000	450	1730
		HLMP-EL30-NR000	HLMP-EL32-NR000	590	2200
		HLMP-EL30-PQ000		765	1730
		HLMP-EL30-PQK00*		765	1730
		HLMP-EL30-PR000		765	2200
		HLMP-EL30-PR400**		765	2200
		HLMP-EL30-PRK00*		765	2200
		HLMP-EL30-PS000	HLMP-EL32-PS000	765	2900
		HLMP-EL30-PSK00*		765	2900
	Orange 605	HLMP-EJ30-NR000	HLMP-EJ32-NR000	590	2200
		HLMP-EJ30-PS000	HLMP-EJ32-PS000	765	2900
		HLMP-EJ30-QT000	HLMP-EJ32-QT000	1000	3700
	Red-Orange 615	HLMP-EH30-MQ000	HLMP-EH32-MQ000	450	1730
		HLMP-EH30-NR000	HLMP-EH32-NR000	590	2200
		HLMP-EH30-PS000	HLMP-EH32-PS000	765	2900
	Red 626	HLMP-EG30-MQ000	HLMP-EG32-MQ000	450	1730
		HLMP-EG30-NQ000		590	1730
		HLMP-EG30-NR000	HLMP-EG32-NR000	590	2200
		HLMP-EG30-PQ000		765	1730
		HLMP-EG30-PR000		765	2200
		HLMP-EG30-PS000	HLMP-EG32-PS000	765	2900

Notes:

1. The luminous intensity is measured on the mechanical axis of the lamp package.
2. The optical axis is closely aligned with the package mechanical axis.
3. The dominant wavelength, λ_d , is derived from the CIE Chromaticity Diagram and represents the color of the lamp.
4. $\theta_{1/2}$ is the off-axis angle where the luminous intensity is one half the on-axis intensity.
5. The intensity of narrow viewing angle lamps is measured at the intensity peak.

Part numbers in **bold** are recommended for new designs.

*HLMP-xLxx-xxK00 are selected to amber color bins 2 and 4 only.

**HLMP-xLxx-xx400 are selected to amber color bin 4 only.

Package Dimensions

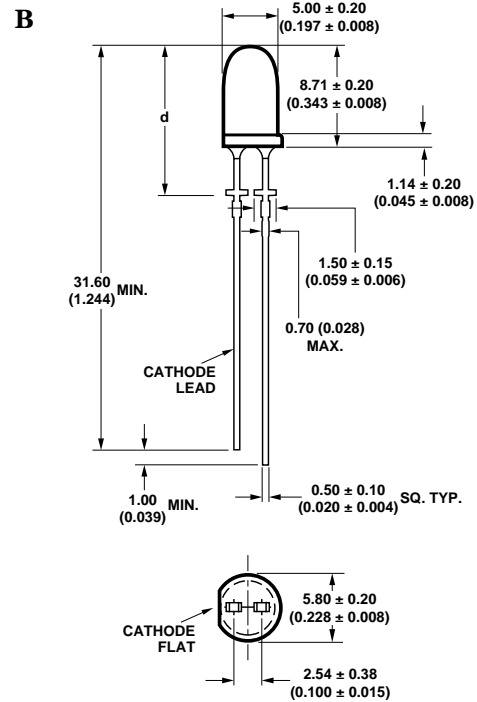
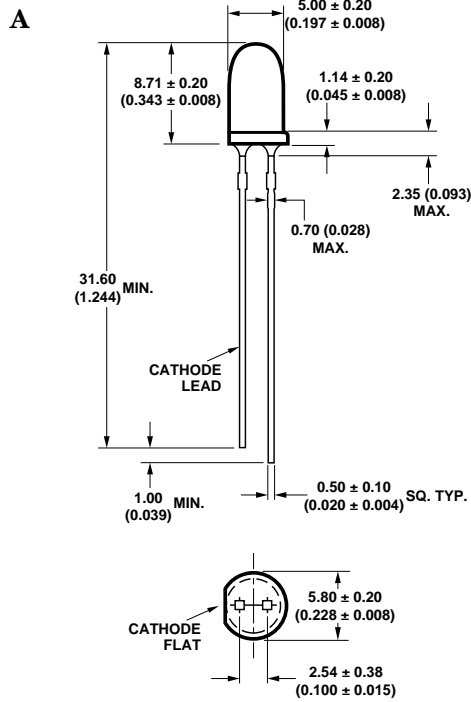

NOTES:

- ALL DIMENSIONS ARE IN MILLIMETERS (INCHES).
- LEADS ARE MILD STEEL, SOLDER DIPPED.
- TAPERS SHOWN AT TOP OF LEADS (BOTTOM OF LAMP PACKAGE) INDICATE AN EPOXY MENISCUS THAT MAY EXTEND ABOUT 1 mm (0.040 in.) DOWN THE LEADS.
- RECOMMENDED PC BOARD HOLE DIAMETERS:
 - LAMP PACKAGE A WITHOUT STAND-OFFS: FLUSH MOUNTING AT BASE OF LAMP PACKAGE = 1.143/1.067 (0.044/0.042).
 - LAMP PACKAGE B WITH STAND-OFFS: MOUNTING AT LEAD STAND-OFFS = 0.965/0.889 (0.038/0.035).
- FOR DOME HEIGHTS ABOVE LEAD STAND-OFF SEATING PLANE, d , LAMP PACKAGE B, SEE TABLE.

PART NO.	d
HLMP-XX10	12.37 ± 0.25 (0.487 ± 0.010)
HLMP-XX17	12.42 ± 0.25 (0.489 ± 0.010)
HLMP-XX26	12.52 ± 0.25 (0.493 ± 0.010)
HLMP-XX32	11.96 ± 0.25 (0.471 ± 0.010)

Absolute Maximum Ratings at $T_A = 25^\circ\text{C}$

DC Forward Current ^[1,2,3]	50 mA
Peak Pulsed Forward Current ^[2,3]	100 mA
Average Forward Current ^[3]	30 mA
Reverse Voltage ($I_R = 100 \mu\text{A}$)	5 V
LED Junction Temperature	130°C
Operating Temperature	-40°C to +100°C
Storage Temperature	-40°C to +120°C
Dip/Drag Soldering Temperature	260°C for 6 seconds
Through-the-Wave Preheat Temperature	145°C
Through-the-Wave Solder Temperature	245°C for 3 seconds
[1.59 mm (0.060 in.) below seating plane]	

Notes:

1. Derate linearly as shown in Figure 4.
2. For long term performance with minimal light output degradation, drive currents between 10 mA and 30 mA are recommended. For more information on recommended drive conditions, please refer to Application Brief I-024 (5966-3087E).
3. Operating at currents below 1 mA is not recommended. Please contact your local representative for further information.

Electrical/Optical Characteristics at $T_A = 25^\circ\text{C}$

Parameter	Symbol	Min.	Typ.	Max.	Units	Test Conditions
Forward Voltage Amber ($\lambda_d = 590 \text{ nm}$) Orange ($\lambda_d = 605 \text{ nm}$) Red-Orange ($\lambda_d = 615 \text{ nm}$) Red ($\lambda_d = 626 \text{ nm}$)	V_F		2.02 1.98 1.94 1.90	2.4	V	$I_F = 20 \text{ mA}$
Reverse Voltage	V_R	5	20		V	$I_F = 100 \mu\text{A}$
Peak Wavelength: Amber ($\lambda_d = 590 \text{ nm}$) Orange ($\lambda_d = 605 \text{ nm}$) Red-Orange ($\lambda_d = 615 \text{ nm}$) Red ($\lambda_d = 626 \text{ nm}$)	λ_{PEAK}		592 609 621 635		nm	Peak of Wavelength of Spectral Distribution at $I_F = 20 \text{ mA}$
Spectral Halfwidth	$\Delta\lambda_{1/2}$		17		nm	Wavelength Width at Spectral Distribution $1/2$ Power Point at $I_F = 20 \text{ mA}$
Speed of Response	τ_s		20		ns	Exponential Time Constant, e^{-t/τ_s}
Capacitance	C		40		pF	$V_F = 0, f = 1 \text{ MHz}$
Thermal Resistance	$R\theta_{\text{J-PIN}}$		240		$^\circ\text{C/W}$	LED Junction-to-Cathode Lead
Luminous Efficacy ^[1] Amber ($\lambda_d = 590 \text{ nm}$) Orange ($\lambda_d = 605 \text{ nm}$) Red-Orange ($\lambda_d = 615 \text{ nm}$) Red ($\lambda_d = 626 \text{ nm}$)	η_v		480 370 260 150		lm/W	Emitted Luminous Power/Emitted Radiant Power

Note:

1. The radiant intensity, I_e , in watts per steradian, may be found from the equation $I_e = I_v/\eta_v$, where I_v is the luminous intensity in candelas and η_v is the luminous efficacy in lumens/watt.

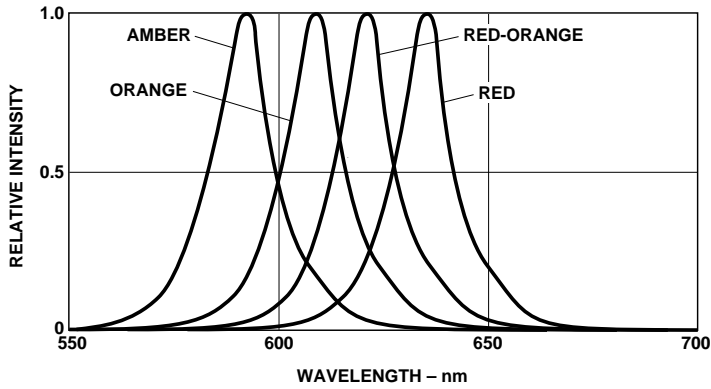

Figure 1. Relative Intensity vs. Peak Wavelength.

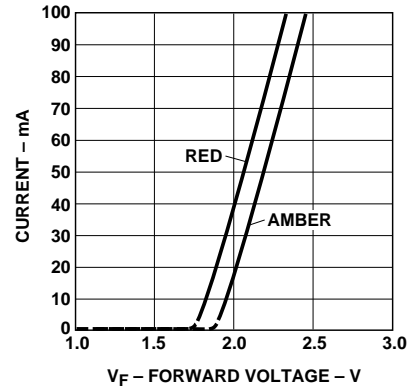

Figure 2. Forward Current vs. Forward Voltage.

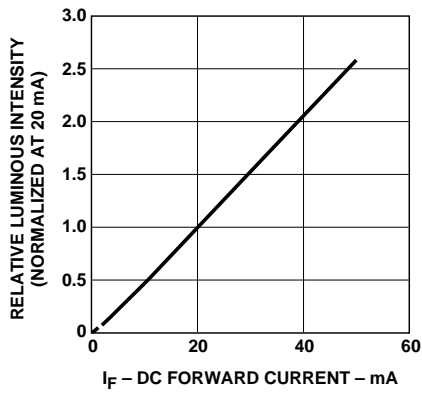

Figure 3. Relative Luminous Intensity vs. Forward Current.

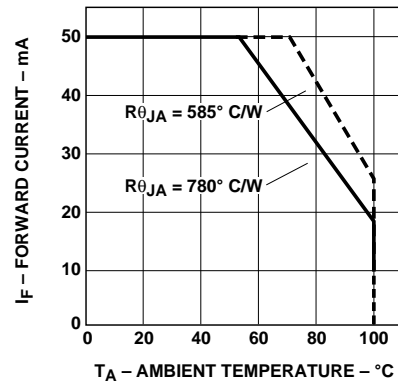

Figure 4. Maximum Forward Current vs. Ambient Temperature. Derating Based on T_{JMAX} = 130 °C.

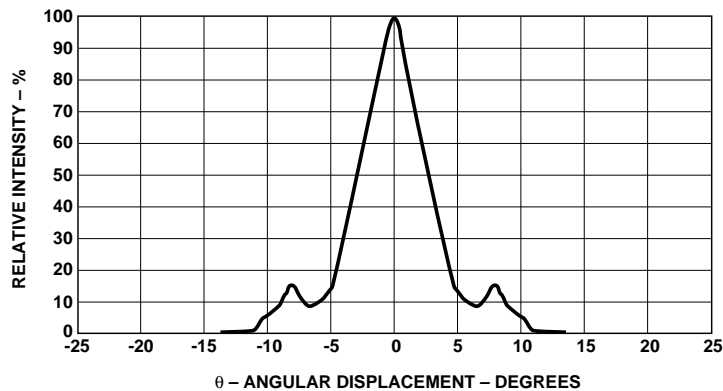

Figure 5. Representative Spatial Radiation Pattern for 6 ° Viewing Angle Lamps.

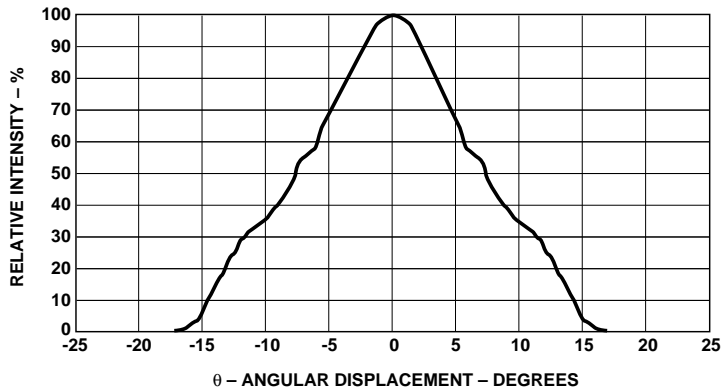

Figure 6. Representative Spatial Radiation Pattern for 15° Viewing Angle Lamps.

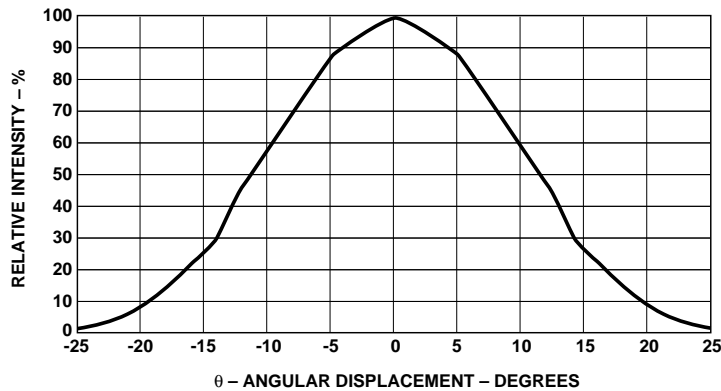

Figure 7. Representative Spatial Radiation Pattern for 23° Viewing Angle Lamps.

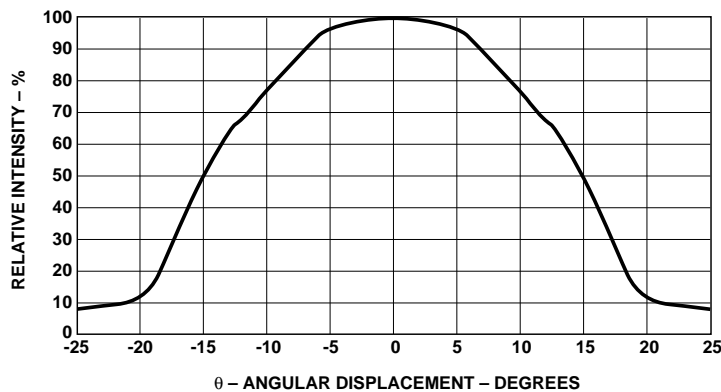

Figure 8. Representative Spatial Radiation Pattern for 30° Viewing Angle Lamps.

Intensity Bin Limits (mcd at 20 mA)

Bin Name	Min.	Max.
K	310	400
L	400	520
M	520	680
N	680	880
P	880	1150
Q	1150	1500
R	1500	1900
S	1900	2500
T	2500	3200
U	3200	4200
V	4200	5500
W	5500	7200
X	7200	9300
Y	9300	12000
Z	12000	16000
1	16000	21000
2	21000	27000

Tolerance for each bin limit is $\pm 15\%$.

HLMP-xLxx Color Bin Limits (nm at 20 mA)

Bin Name	Min.	Max.
1	584.5	587.0
2	587.0	589.5
4	589.5	592.0
6	592.0	594.5

Tolerance for each bin limit is ± 0.5 nm.

Note:

1. Bin categories are established for classification of products. Products may not be available in all bin categories.

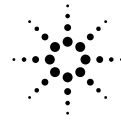

Agilent Technologies
Innovating the HP Way

www.semiconductor.agilent.com

Data subject to change.

Copyright © 1999 Agilent Technologies, Inc.

Obsoletes 5968-7459E

5968-4744E (11/99)