

**Ordering number CA11181_BROOKE-S**

Family	Brooke	FWHM	24 degrees
Type	Reflector	Efficiency	94 %
LED	BXRA ES Rectangle	cd/lm	-
Color	Metal	Gerber File	Available
Diameter	45 mm		
Height	20.1 mm		
Style	Round		
Optic Material	PC		
Holder Material	-		
Fastening	Tape		
Status	Ready		

**Ordering number CA11182_BROOKE-M**

Family	Brooke	FWHM	32 degrees
Type	Reflector	Efficiency	93 %
LED	BXRA ES Rectangle	cd/lm	-
Color	Metal	Gerber File	Available
Diameter	45 mm		
Height	21.1 mm		
Style	Round		
Optic Material	PC		
Holder Material	-		
Fastening	Tape		
Status	Ready		

**Ordering number CA11183_BROOKE-W**

Family	Brooke	FWHM	50 degrees
Type	Reflector	Efficiency	92 %
LED	BXRA ES Rectangle	cd/lm	-
Color	Metal	Gerber File	Available
Diameter	45 mm		
Height	21.1 mm		
Style	Round		
Optic Material	PC		
Holder Material	-		
Fastening	Tape		
Status	Ready		

NOTE: The typical divergence will be changed by different color, chip size and chip position tolerance. The typical total divergence is the full angle measured where the luminous intensity is half of the peak value.



PRODUCT DATASHEET

Brooke series

last update 26/7/2012



GENERAL INFORMATION

- Product series especially designed & optimized for BXRA ES Rectangle series of LEDs.
- Special care taken to make light distribution as uniform as possible.
- Reflector is made of aluminium coated PC (120 degrees of Celcius / 248 degrees of Fahrenheit) with protective lacquer (110 degrees of Celcius / 230 degrees of Fahrenheit).
- Fastening to heat sink with a PU foam adhesive tape of automotive grade. Please find fastening details by clicking link: http://www.ledil.com/datasheets/DataSheet_TAPE.pdf

NOTE 1: We advise customer to ensure the suitability and sufficiency of the bond in the end product. For example, mechanical stress, vibration and holes on the surface of the circuit board weaken the strength of the tape.

NOTE 2: Assembly to the surface must be made straight, so the tape bonds constant and balanced with fastening surface. Slanted assembly might cause unbalanced bond to the surface. All surfaces where tape is applied must be clean, dry and free from grease and dirt.

If cleaning of PCB surfaces is needed, please follow strictly the cleaning instructions of your LED manufacturer - this is important as cleaning shall under no circumstances damage LEDs or other electronics components on the PCB.

Further note that optical components shall not be cleaned with any chemicals - only micro fiber cloth may be used to remove fingerprints or other traces from handling.

Relative Intensity of CA11183_Brooke-W

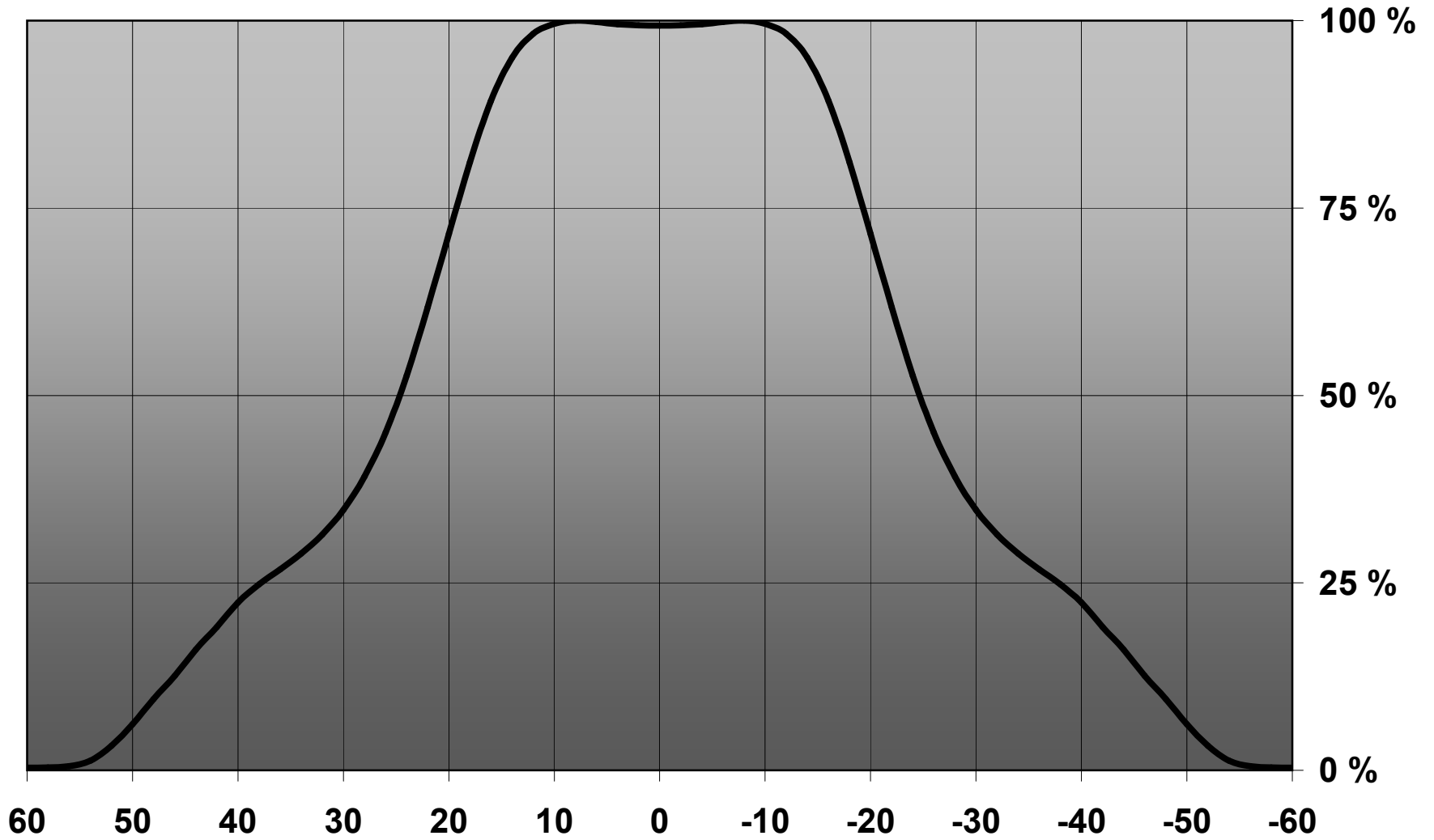

D

C

B

A

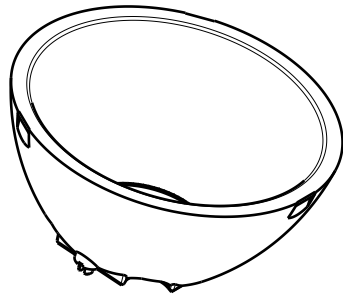

Isometric view

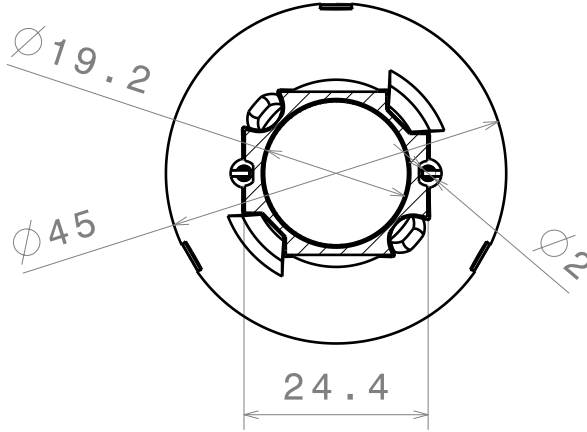

Bottom view

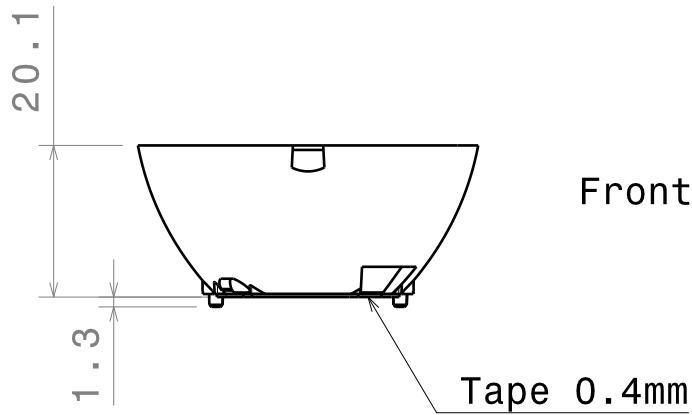

Front view

Material: PC with metal coating

Part no.s:
 CA11181 Spot
 CA11182 Medium
 CA11183 Wide

This drawing is our property.
 It can't be reproduced
 or communicated without
 our written agreement.



Ledil Oy
 Tehdaskatu 13
 FIN-24100 SALO
 Finland

DRAWING TITLE

Datasheet Brooke Reflector Series

DRAWN BY pv	DATE 15.10.2009
----------------	--------------------

CHECKED BY hh	DATE 08.10.2009
------------------	--------------------

DESIGNED BY ol	DATE 08.10.2009
-------------------	--------------------

SIZE A4	DRAWING NUMBER CA11181-183	REV 1
------------	-------------------------------	----------

SCALE 1:1	WEIGHT (g)	SHEET 1/1
--------------	------------	--------------

D

A

4

4

3

3

2

2

1

1