



# DIN Signal har-bus 64S female connector



## General information

Design	according to IEC 61076-4-113	type: har-bus64S female with switching elements
No. of contacts	max. 160	
Contact spacing	2,54mm	
Test voltage	1000V	
Contact resistance	max. 20mOhm for rows a, b, c / max. 30mOhm for rows d, z / max. 60mOhm for switching elements	
Insulation resistance	min. 10 <sup>10</sup> Ohm	
Working current	1A at 70°C (see derating diagram)	
Temperature range	-55°C ... +125°C	
Termination technology	press-in	

Clearance & creepage		minimum distance		switches
		rows a, b, c	rows d, z	
between 2 contacts in a row	clearance	between 2 rows	1,2mm	0,5mm
		creepage	1,2mm	0,7mm
	creepage	between 2 rows	1,2mm	1,0mm
		between 2 contacts in a row	1,2mm	1,0mm

Insertion and withdrawal force	max. 180N
PCB thickness	min. 1,6mm
Mating cycles	PL 2 acc. to IEC 61076-4-113 250 mating cycles
UL file	E102079
RoHS - compliant	Yes
Leadfree	Yes

## Insulator material

Material	LCP (Liquid Cristal Polymer)
Colour	nature (black for cover on switching elements)
UL classification	UL 94-V0
Material group acc. to IEC 60664-1	IIIa (175 ≤ CTI < 400)

## Contact material

Contact material	Copper alloy
Plating termination zone	Ni
Plating contact zone	Au over Ni

## Derating diagram acc. to IEC 60512-5 (Current carrying capacity)

The current carrying capacity is limited by maximum temperature of materials for inserts and contacts including terminals.

The current capacity curve is valid for continuous, non interrupted current loaded contacts of connectors when simultaneous power on all contacts is given, without exceeding the maximum temperature.  
Control and test procedures according to DIN IEC 60512-5

With selective loading higher currents can be transmitted. The requirements according to VITA 1.7 are fulfilled.

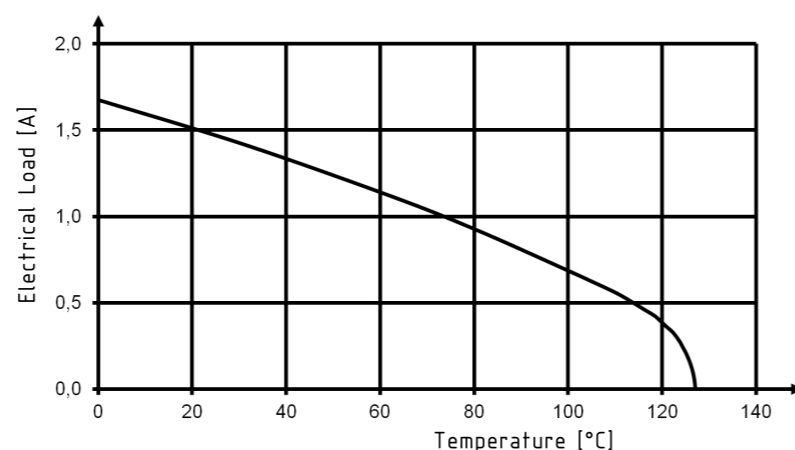

## Recommended configuration of plated through holes for press-in termination

In addition to the hot-air-level (HAL), other PCB surfaces are getting more important. Due to their different properties - such as mechanical strength and coefficient of friction - we recommend the following configuration of PCB through holes.

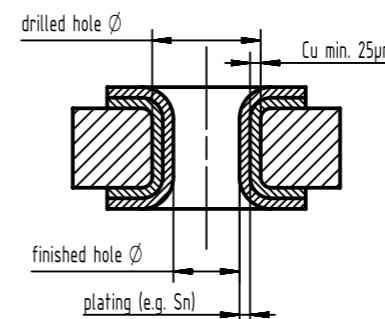

PCB Type	Plating	Drilled hole Ø	Plated hole Ø
Tin plated PCB (HAL) acc. to EN 60352-5	Sn	1,15±0,025 mm	max. 15 µm
			0,94 - 1,09 mm
Chemical tin plated PCB	Sn	1,15±0,025 mm	min. 0,8µm
			1,00 - 1,10 mm
Gold /Nickel plated PCB	Ni	1,15±0,025 mm	3 - 7 µm
	Au		0,05 - 0,12 µm
			1,00 - 1,10 mm
Silver plated PCB	Ag	1,15±0,025 mm	0,1 - 0,3 µm
			1,00 - 1,10 mm
Copper plated PCB (OSP)		1,15±0,025 mm	
			1,00 - 1,10 mm

## Assembly instructions

It is highly recommended to use HARTING press-in tools to ensure a reliable press-in process. Please refer to the catalogue for tools, machines and further information about the press-in process.

## Additional information

The 5-row har-bus@64 connector with switches allows an automatic switching. In the case of an unmated daughter card the connector bridges the signals at positions a21-22, b4-5, b6-7, b8-9 and b10-11. Switching elements open automatically when the daughter card is mated, so that the daughter card accepts the ongoing signal daisy-chain.

	All Dimensions in mm Original Size DIN A3	Scale 1:1	Free size tol.	Ref. Sub. DS 02032100101 / EC01482 / 21.04.2011
	All rights reserved Department EC PD - DE	Created by TADJE	Inspected by ZWHR	Standardisation HOFFMANN
HARTING Electronics GmbH D-32339 Espelkamp	Title DIN Signal har-bus 64S female connector with switch			Doc-Key / ECM-Nr. 100557034/UGD/001/A 50000068472
	Type DS	Number 02032100101	Rev. A	Page 1/1