



Extract from the online catalog

SACB-8/ 8-L-10,0PUR SCO

Order No.: 1517178



<http://eshop.phoenixcontact.de/phoenix/treeViewClick.do?UID=1517178>

Sensor/actuator box, with SPEEDCON rapid interlock with LED, master cable, markers and single-assigned slots, slots: 8, cable length: 10 m

Commercial data	
EAN	4017918967840
Pack	1 pcs.
Customs tariff	85366990
Weight/Piece	1.4842 KG
Catalog page information	Page 116 (PC-2009)

Product notes

WEEE/RoHS-compliant since:
11/13/2006



<http://www.download.phoenixcontact.com>
Please note that the data given here has been taken from the online catalog. For comprehensive information and data, please refer to the user documentation. The General Terms and Conditions of Use apply to Internet downloads.

Technical data

General data	
Nominal voltage U_N	24 V DC
Max. operating voltage U_{max}	30 V DC
Max. current carrying capacity per path	2 A
Current carrying capacity per slot	4 A

SACB-8/ 8-L-10,0PUR SCO Order No.: 1517178
<http://eshop.phoenixcontact.de/phoenix/treeViewClick.do?UID=1517178>

SACB total current	12 A
Operating current of the indicator elements	≤ 5 mA
Number of positions	4
Number of slots	8
Degree of protection	IP65/IP67/IP69K
Inflammability class acc. to UL 94	V0
Ambient temperature (operation)	-30 °C ... 90 °C
Sensor/actuator connection system	M12-SPEEDCON-socket
Local diagnostics function	
Local diagnostics	Supply voltage LED green
	Status display I/O Yellow LED
Master cable data	
Type of connection	Fixed connection
Length of cable	10 m
Cable type	Master cable suitable for flexible cable conduit
Signal line cross section	8x 0.34 mm ²
AWG signal line	22
Conductor structure, signal line	42x 0.10 mm
Power supply cross section	3x 0.75 mm ²
AWG power supply	19
Conductor structure, voltage supply	96x 0.10 mm
External diameter	9.2 mm
Max. bending cycles	1500000
Bending radius	95 mm
Traversing path	2 m
Traversing rate	2 m/s
Ambient temperature (operation)	-40 °C ... 90 °C (for fixed installation)
	-5 °C ... 80 °C (for flexible installation)
Tightening torque slot sensor/actuator cable	0.4 Nm
Tightening torque screw plug	0.4 Nm
Insulation material	
Housing material	PBT
Material of the moulding mass	PUR
Contact material	Cu alloy

SACB-8/ 8-L-10,0PUR SCO Order No.: 1517178
http://eshop.phoenixcontact.de/phoenix/treeViewClick.do?UID=1517178

Contact surface material	Gold-plated
Contact carrier material	PA
Material of threaded sleeve	Zinc die-cast
Material of threaded sleeve surface	Nickel-plated
Material, O-ring	NBR

Pin assignment

Slot/position = Wire color or connection	1 / 4 (A) = WH
	2 / 4 (A) = GN
	3 / 4 (A) = YE
	4 / 4 (A) = GY
	5 / 4 (A) = PK
	6 / 4 (A) = RD
	7 / 4 (A) = BK
	8 / 4 (A) = VT
	1-8 / 1 (+ 24 V) = BN
	1-8 / 3 (0 V) = BU
	1-8 / 5 (PE) = GN/YE

Certificates / Approvals



Certification CUL, UL

CUL

Nominal voltage U_N	24 V
Nominal current I_N	3 A

UL

Nominal voltage U_N	24 V
Nominal current I_N	3 A

SACB-8/ 8-L-10,0PUR SCO Order No.: 1517178
<http://eshop.phoenixcontact.de/phoenix/treeViewClick.do?UID=1517178>

Drawings

Dimensioned drawing

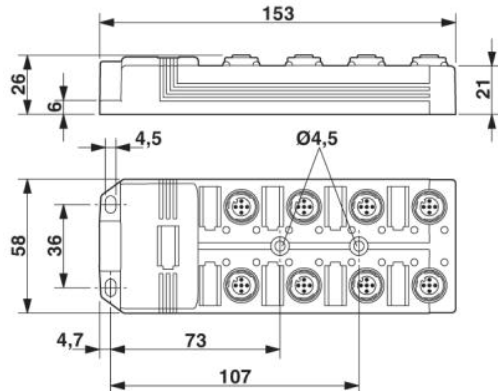

Circuit diagram

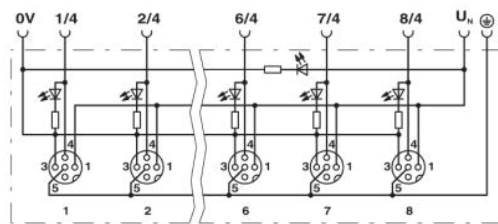

Schematic diagram

M12 slot, socket, 4-pos.

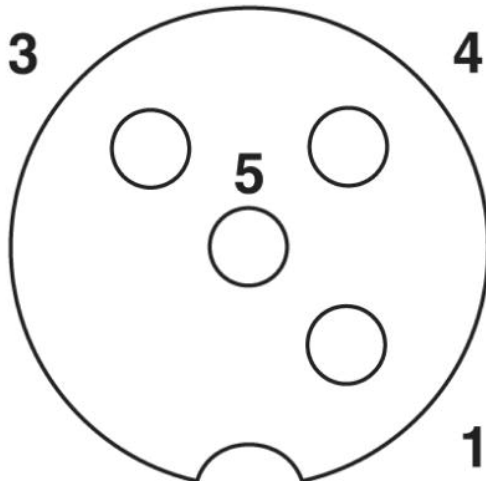

SACB-8/ 8-L-10,0PUR SCO Order No.: 1517178
<http://eshop.phoenixcontact.de/phoenix/treeViewClick.do?UID=1517178>

Address

PHOENIX CONTACT Deutschland GmbH
Flachmarktstr. 8
32825 Blomberg, Germany
Phone +49 5235 3 12000
Fax +49 5235 3 41200
<http://www.phoenixcontact.de>



© 2010 Phoenix Contact
Technical modifications reserved;

onlinecomponents.com