

CLASS NO.	TITLE 回転形エンコーダ 規格書 ROTATIONALENCODER SPECIFICATION	EC11G1534414 (SW01)
-----------	----------------------------------------------------------	------------------------

1. 一般事項 General
- 1-1 適用範囲 Scope
この仕様書は主として電子機器に用いる微小電流回路用11形薄形ロータリーエンコーダに適用する。
This specification applies to 11mm size low-profile rotary encoder (incremental type) for microscopic current circuits, used in electronic equipment.
- 1-2 標準状態 Standard atmospheric conditions
測定は特に指定のない限り、次の状態で行なう。
Unless otherwise specified, the standard range of atmospheric conditions for making measurements and tests is as follows:
 温度 Ambient temperature : 15°C to 35°C
 相対湿度 Relative humidity : 25% to 85%
 気圧 Air pressure : 86kPa to 106kPa
 但し、疑義を生じた場合は、次の基準状態で行なう。
 If there is any doubt about the results, measurements shall be made within the following limits:
 温度 Ambient temperature : 20 ± 1°C
 相対湿度 Relative humidity : 63% to 67%
 気圧 Air pressure : 86kPa to 106kPa
- 1-3 使用温度範囲
Operating temperature range : -40°C to +85°C
- 1-4 保存温度範囲
Storage temperature range : -40°C to +85°C
2. 構造 Construction
- 2-1 寸法 Dimensions
添付組立図による。
Refer to attached drawing.
3. 定格 Rating
- 3-1 定格容量 Rating : D.C. 5V 10mA (1mA MIN)
4. 電気的性能 Electrical characteristics

項目 Item	条件 Conditions	規格 Specifications		
4-1 出力信号 Output signal format		A, B 2 信号の位相差出力とし、詳細は <fig. 1> の通りとする。 2 Phase-different signals (Signal A, signal B) Details shown in <fig. 1>.		
		軸回転方向 Shaft rotational direction	信号 Signal	出力波形 Output
		時計方向 C.W.	A (A-C 端子間) A (Terminal A-C)	OFF ON
			B (B-C 端子間) B (Terminal B-C)	OFF ON
		反時計方向 C.C.W.	A (A-C 端子間) A (Terminal A-C)	OFF ON
			B (B-C 端子間) B (Terminal B-C)	OFF ON

EC11G153
15P/0C

ALPS ELECTRIC CO., LTD.

SYMB	DATE	APPD	CHKD	DSGD	APPD 論・設計課 07.8.1 池之上	CHKD	DSGD 論・設計課 07.8.1 清水	TITLE 回転形エンコーダ ROTATIONALENCODER	DOCUMENT NO. 5LA211-G37 (1/4)
------	------	------	------	------	--------------------------------	------	-------------------------------	----------------------------------------	----------------------------------

APPROVED 01/20/2010

品番 815100-11510700 図種 26 版数 01 (4/19)

CLASS No.	TITLE 回転形エンコーダ 規格書 ROTATIONALENCODER SPECIFICATION	(SW01)
-----------	----------------------------------------------------------	--------

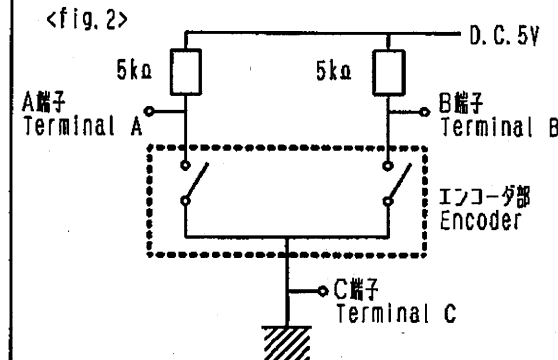
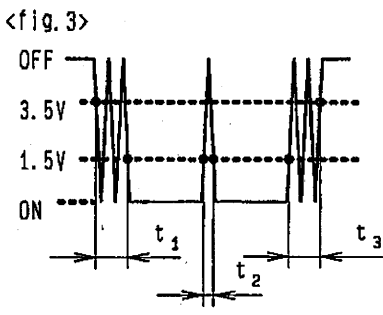
項目 Item	条件 Conditions	規格 Specifications
4-2 分解能 Resolution	1回転区で出力されるパルス数 Number of pulses in 360° rotation.	各相15パルス/360° 15 pulses/360° for each phase
4-3 スイッチング特性 Switching characteristics	<p>下記測定回路<fig. 2>を用い、回転軸を$360^\circ \cdot s^{-1}$の速さで回転し測定する。 Measurement shall be made under the condition as follows.</p> <p>1) Shaft rotational speed : $360^\circ \cdot s^{-1}$ 2) Test circuit : <fig. 2></p> <p><fig. 2></p>  <p><fig. 3></p>  <p>(注記) コーD OFF状態 : 出力電圧が3.5V以上の状態を言う。 コーD ON状態 : 出力電圧が1.5V以下の状態を言う。 (note) Code-OFF area : The area which the voltage is 3.5V or more. code-ON area : The area which the voltage is 1.5V or less.</p>	
1) チャタリング Chattering	<p>コーDのOFF→ON及びON→OFFの際の、出力1.5V~3.5Vの通過時間にて規定する。 Specified by the signal's passage time from 3.5V to 1.5V or from 1.5V to 3.5V of each switching position (code OFF→ON or ON→OFF).</p>	$t_1, t_3 \leq 3ms$
2) 振動ノイズ (バウンス) Sliding noise (Bounce)	<p>コーD ONの部分の1.5V以上の電圧変動時間とし、チャタリングt_1, t_3両者との間に1ms以上の1.5V以下のON部分を有するものとする。また、振動ノイズ間に1.5V以下の範囲が1msある場合は、別の振動ノイズと判断する。 Specified by the time of voltage change exceed 1.5V in code-ON area. When the bounce has code-ON time less than 1ms between chattering (t_1 or t_3), the voltage change shall be regarded as a part of chattering. When the code-ON time between 2 bounces is less than 1ms, they are regarded as 1 linked bounce.</p>	$t_2 \leq 2ms$
3) 振動ノイズ Sliding noise	<p>コーD OFFの部分の電圧変動 The voltage change in code-OFF area.</p>	3.5V以上 3.5V MIN

					ALPS ELECTRIC CO., LTD.			
SYMB	DATE	APPD	CHKD	DSGD	APPD 池・設計試作 07.8.1 池之上	CHKD	DSGD 池・設計試作 07.8.1 清水	TITLE 回転形エンコーダ ROTATIONALENCODER
					DOCUMENT NO. 5LA211-G37 (2/4)			

CLASS NO.	TITLE 回転形エンコーダ 規格書 ROTATIONALENCODER SPECIFICATION	(SW01)
-----------	----------------------------------------------------------	--------

項目 Item	条件 Conditions	規格 Specifications
4-4 位相差 Phase-difference	<p>360°・s⁻¹の定速にて操作軸を回転する。 Measurement shall be made under the condition which the shaft is rotated in 360°・s⁻¹ (constant speed).</p> <p><fig. 4></p> <p>注意事項：搭拠接点ですので手動操作時の出力波形はご使用されるツマミ径、軸の回転速度によって変化致します。回路設計時は実装にて確認願います。 Note: Above specification (4-4) is changeable. When operate by manual. Please check performance using actual circuit and knob.</p>	<fig. 4>において ΔT≥6ms In<fig. 4>
4-5 絶縁抵抗 Insulation resistance	端子-軸受間D. C. 250V印加する。 Measurement shall be made under the condition which a voltage of 250V D. C. is applied between individual terminals and bushing.	端子-軸受間にて100MΩ以上 Between individual terminals and bushing: 100MΩ MIN.
4-6 耐電圧 Dielectric strength	端子-軸受間E. C. 300V1分間又は、A. C. 360V2秒間印加する。 (リーク電流1mA) A voltage of 300V A. C. shall be applied for 1min or a voltage of 360V A. C. shall be applied for 2s between individual terminals and bushing. (Leak current:1mA)	損傷・アーク・絶縁破壊がないこと。 Without damage to parts, arcing or breakdown.

5. 機械的性能 Mechanical characteristics

項目 Item	条件 Conditions	規格 Specifications
5-1 全回転角度 Total rotational angle		360° (エンドレス) 360° (Endless)
5-2 回転トルク Rotational torque	(1回転後の始動トルクを含む)	8.5±2.5mN・m (をだし、初期出荷時のみと) 最大値での管理とする。
5-3 端子強度 Terminal strength	端子先端の任意の方向に5Nの力を1分間加える。 A static load of 5N be applied to the tip of terminals for 1min in any direction.	端子の破損、著しいカクタがないこと。 但し、端子の曲がりは可とする。 Without damage or excessive looseness of terminals. Terminal bend is permitted.

ALPS ELECTRIC CO., LTD.

APPD. 補設計 07.12.10 池之上	CHKD.	DSGD. 補設計 07.12.10 清水	TITLE 回転形エンコーダ ROTATIONALENCODER
ORIGINAL 2007-08-01 池之上	—	清水	DOCUMENT NO. 5LA211-G37 (3/4)
SYMB	DATE	APPD	CHKD

CLASS NO.	TITLE 回転形エンコーダ 規格書 ROTATIONAL ENCODER SPECIFICATION	(SW01)
-----------	-----------------------------------------------------------	--------

項目 Item	条件 Conditions	規格 Specifications
5-3 軸の押し引き強度 Push-pull strength of shaft	軸の押し及び引き方向に100Nの力を10秒間加える。 (セット実装状態) Push and pull static load of 100N shall be applied to the shaft in the axial direction for 10s. (After installing)	軸の破損、著しいガタのないこと。 感触に異常がないこと。 Without damage or excessive play in shaft. No excessive abnormality in rotational feeling.
5-4 軸ガタ Shaft wobble	軸先端から5.2mmの位置に1Nの力を加える。 Force of 1N to be applied at the point 2mm from the tip of the shaft.	0.2 mmp-p 以下 less
5-5 軸のスラスト方向ガタ Shaft play in axial direction		0.4 mm 以下 less.
5-6 軸の回転方向ガタ Rotation play at the click position	角度板にて測定する。 Measure with jig for rotational angle.	3°以内 3 MAX.
5-7 取付け上の注意 Notice for mounting	右図の様にスイッチ本体を挿えてご使用下さい。セット側でスイッチ本体の引き及び回転方向の「イト」が無い場合は、はんだ付けだけの固定となり、はんだ付け信頼性及びスイッチ本体強度が不安定となる可能性があります。 Hold the bushing use front panel or light pipe. Because this switch not has thread, if don't hold the bushing, the switch maybe become intermittent rough mounting after soldering by knob stopper face.	

6. 耐久性能 Endurance characteristics.

項目 Item	条件 Conditions	規格 Specifications
6-1 回転寿命性能 Rotational life	無負荷で軸を毎時500サイクルの速さで、15,000サイクル連続動作を行う。但し、試験途中5,000で中間測定を行う。(1サイクルは、360°1往復) The shaft of encoder shall be rotated to 15,000 cycles at a speed of 500 cycles per hour without electrical load, after which measurements shall be made. However, an interim measurement shall be made immediately after 5,000 cycles. (1 cycle: rotate 360° CCW rotate 360° CW)	回転トルクは 初期規格値に対し $\pm 10\%$ $\pm 30\%$ その他、初期規格を満足すること。 Rotational torque: Relative to the previously specified value. $\pm 10\%$ $\pm 30\%$ Except above items, specifications in clause 4.1-4.6 and 5.1, 5.3 shall be satisfied.

ALPS ELECTRIC CO., LTD.

SYMB	DATE	APPD	CHKD	DSGD	APPD 池之上 07.8.1	CHKD	DSGD 清水 07.8.1	TITLE 回転形エンコーダ ROTATIONAL ENCODER	DOCUMENT NO. 5LA211-G37 (4/4)
------	------	------	------	------	-----------------------	------	----------------------	-----------------------------------------	----------------------------------

CLASS No.	TITLE プッシュモーメントリスイッチ規格書 PUSH MOMENTARY SWITCH SPECIFICATION	(SW02)
-----------	-------------------------------------------------------------------	--------

1. 定格容量 (抵抗負荷)
Switch rating (Resistor load) D.C. 16V 0.5A (1mA MIN)
2. 電気的性能 Electrical characteristics

項目 Item	条件 Conditions	規格 Specifications
2-1 接触抵抗 Contact resistance	D.C. 5V 1mA電圧降下法にて測定する。 Measured by the 1mA 5V D.C. voltage drop method.	100mΩ以下 100mA MAX.
2-2 チャタリング Chattering	1サイクル (OFF-ON-OFF) 1秒で動作させる。 Switch is operated at the rate of 1 cycle 1 s. The 1 cycle shall be OFF-ON-OFF.	10ms 以下 10ms MAX.
2-3 絶縁抵抗 Insulation resistance	端子-軸受間D.C. 250V印加する。 Measurement shall be made under the condition which a voltage of 250V D.C. is applied between individual terminals and bushing.	端子-軸受間にて100MΩ以上 Between individual terminals and bushing: 100MΩ MIN.
2-4 耐電圧 Dielectric strength	端子-軸受間A.C. 300V1分間又は、A.C. 360V2秒間印加する。(リーク電流1mA) A voltage of 300V A.C. shall be applied for 1min or a voltage of 360V A.C. shall be applied for 2s between individual terminals and bushing. (Leak current: 1mA)	損傷・アーク・絶縁破壊がないこと。 Without damage to parts arcing or breakdown.

注記: 軸・スイッチ端子間は絶縁されております。
Note: Shaft is insulated from switch terminal.

3. 機械的性能 Mechanical characteristics

項目 Item	条件 Conditions	規格 Specifications
3-1 スイッチ回路・接点数 Contact arrangement		単極単投 (Push on) S. P. S. T. (Push on)
3-2 スイッチ移動量 Switching stroke	スラストガタを除く Without shaft free play in thrust direction.	1.5 ± 0.3mm
3-3 スイッチ作動力 Switch operation force		5 ± 1.5 N

4. 耐久性能 Endurance characteristics.

項目 Item	条件 Conditions	規格 Specifications
4-1 動作寿命特性 Operating life	無負荷にて軸を毎時500回の速さで20,000回断続動作を行う。 起し、試験途中5,000回で中間測定を行う。 The shaft of switch shall be 20,000 times at a speed of 500 times per hour without electrical load, after which measurements shall be made. However, an interim measurement shall be made immediately after 5,000 times.	接触抵抗: 200mΩ以下 その他、初期規格を満足すること。 Switch contact resistance: 200mA MAX. Except above items, specifications in clause 2.2~2.4, and 3.1~3.3 shall be satisfied.

5. その他 Note

- 5-1 軸にツマミを取り付け、センターから10mmの位置で押し込んだ時にひっかかり感がないこと。
No sticky feel shall be observed when the knob on the shaft is pushed at 10mm of the center.

6. 注意事項 Note

- 6-1 プッシュスイッチ付のエンコーダは、軸が押し込まれたままの状態では梱包や保管をされず、スイッチ部に支障をきたす恐れがありますので、ご注意ください。
Encoder equipped with a push-on switches are packaged or stored with their shaft being pushed-in. The switch part may be out of order and pay attention when you package or store them.

ALPS ELECTRIC CO., LTD.				
SYMB	DATE	APPD	CHKD	DSGD
		池之上		清水
		APPD 池之上 07.12.10	CHKD	DSGD 清水 07.12.10
				TITLE PUSH MOMENTARY SWITCH プッシュモーメントリスイッチ
				DOCUMENT NO. 5LA2114-G7 (1/1)

CLASS No.	TITLE
-----------	-------

1. はんだ耐熱 Resistance to soldering heat

下記の「はんだ付け条件」にて絶縁体の変形、破損のないこと、感熱に異常のないこと。
 At the specified by the soldering conditions below.
 There shall be no deformation or cracks in molded part.
 No excessive abnormality in rotational feeling.

はんだ付け条件 Soldering conditions

手はんだの場合 Manual soldering

⚠ 温度350°C以下、時間3秒以内 ⚠
 Bit temperature of soldering iron : 350°C or less.
 Application time of soldering iron : within 3s.

ディップはんだの場合 Dip soldering

使用基板 : 寸1.6両面銅張り基板
 Printed wiring board: Both-sided copper clad laminate board with thickness of 1.6mm.

フラックス : 比重0.82以上のフラックスを用い発泡式フラクサーにて発泡面高さは、基板厚の3分の2。
 Flux:

- Specific gravity: 0.82 or more.
- Flux shall be applied to the board using a bubble foaming type fluxer.
- The board shall be soaked in the flux bubble only to the 2/3 of its thickness.

プリヒート : 基板表面温度100°C以下、時間2分以内
 Preheating:
 Surface temperature of board: 100°C or less.
 Preheating time: within 2 min.

はんだ : 温度260±5°C、時間5±1秒
 Soldering:
 Solder temperature: 260±5°C.
 Immersion time: within 5±1s.

以上の工程を1回または2回繰り返す。
 Apply the above soldering process for 1 or 2 times.

					 ALPS ELECTRIC CO., LTD.			
					APPD. 1-2	CHKD. 1-2	DSGD. 1-2	TITLE
					K. KAWASAKI	S. MIZOBUCHI	H. MIURA	DOCUMENT NO.
2	2004-02-23	S. M.	H. H.	H. I.	1997/06/12	1997/08/12	1997/06/11	L-E1 (1/1)
SYMB	DATE	APPD	CHKD	DSGD				

注記 軸受材質：亜鉛タ'イキャスト
軸材質：黄銅

NOTES BUSHING MATERIAL: ZINC ALLOY DIE CASTING
SHAFT MATERIAL: BRASS

(SW01) ENCODER
(SW02) PUSH ON SW

SW 移動量
(ただし、スラストカ'タを除く)

SW STROKE
(WITHOUT SHAFT FREE PLAY
IN THRUST DIRECTION)

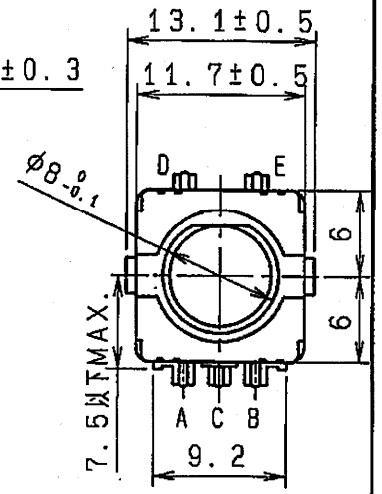
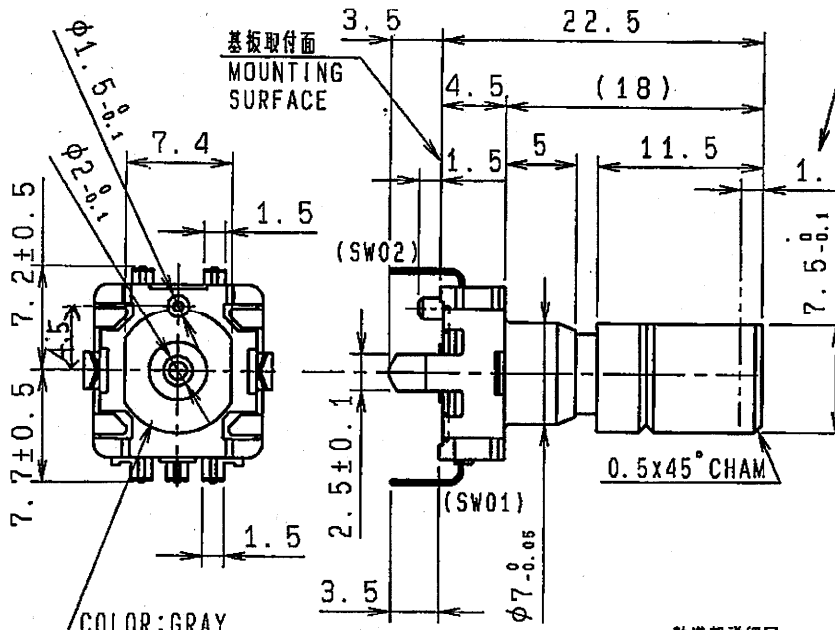

軸角度は任意とする
SHAFT ANGLE IS
OPTIONAL.

軸溝部詳細図
SHAFT DETAIL

取付寸法図 許容差±0.1
(部品挿入側)
P.W.B. MOUNTING DETAIL
TOLERANCE±0.1
VIEWED FROM MOUNTING SIDE

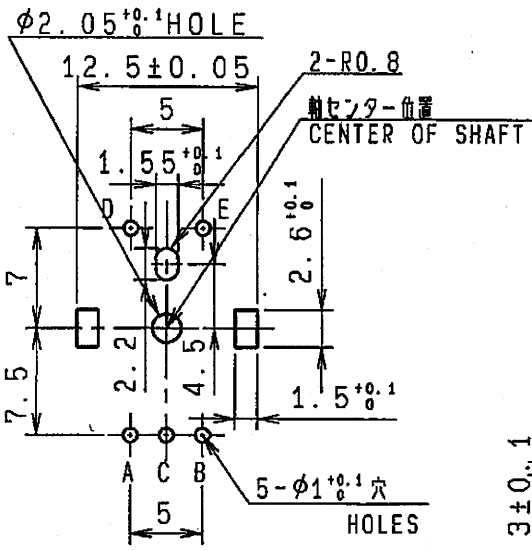

基板板厚 t=1.6mm
P.C.B. THICKNESS t=1.6mm

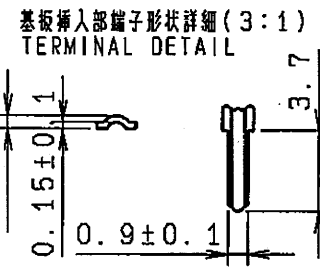
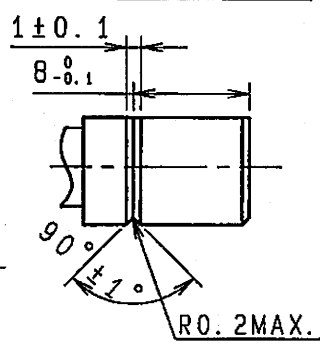

(SW02)回路図
SWITCH CIRCUIT
DIAGRAM

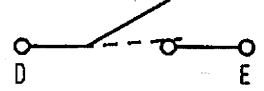

(SW01)出力信号
ENCODER OUTPUT SIGNAL

時計方向回転
CW ROTATION

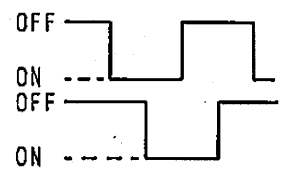

指定なき部分の許容差 TOLERANCES UNLESS OTHERWISE SPEC	
L ≤ 10	±0.3
10 < L < 100	±0.5
100 ≤ L	±0.8
角度 ANGULAR DIMENSION	±5°

				15P/クリック無	
PART NO.	NAME	MATERIAL NAME / CODE	FINISH		
ALPS ELECTRIC CO., LTD.					
DSGD.	M. CHIBA	2010-01-06	SCALE	NO.	
			2:1		
CHKD.	Y. SHIMIZU	2009-01-06		TITLE 11形1軸 PUSH ON SW付エンコーダ'組立図	
APPD.	Y. KATO	2010-01-06	UNIT	DOCUMENT NO.	
SYMB	DATE	APPD	CHKD	DSGD	LA2114G43

APPROVED 01/20/2010

品番 815100-11510700 図種 26 版数 01 (10/19)