

Plastic-Encapsulate MOSFETS

N-Channel 20-V(D-S) MOSFET

FEATURE

TrenchFET Power MOSFET

APPLICATIONS

- Load Switch for Portable Devices
- DC/DC Converter

MARKING: 2302

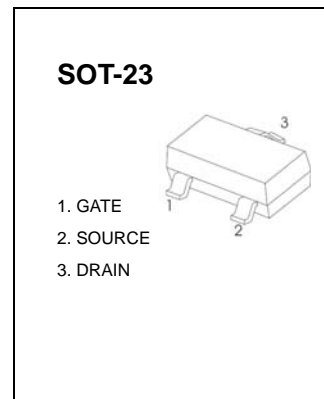
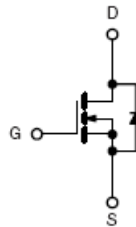

Maximum ratings ($T_a=25^{\circ}\text{C}$ unless otherwise noted)

Parameter	Symbol	Value	Unit
Drain-Source Voltage	V_{DS}	20	V
Gate-Source Voltage	V_{GS}	± 8	
Continuous Drain Current	I_D	2.8	A
Continuous Source-Drain Current(Diode Conduction)	I_S	0.6	
Power Dissipation	P_D	0.35	W
Thermal Resistance from Junction to Ambient ($t \leq 5s$)	$R_{\theta JA}$	357	$^{\circ}\text{C}/\text{W}$
Operating Junction	T_J	150	$^{\circ}\text{C}$
Storage Temperature	T_{STG}	-55 ~ +150	



Electrical characteristics (T_a=25°C unless otherwise noted)

Parameter	Symbol	Test Condition	Min	Typ	Max	Units
Static						
Drain-source breakdown voltage	V _{(BR)DSS}	V _{GS} = 0V, I _D = 10μA	20			V
Gate-threshold voltage	V _{GS(th)}	V _{DS} = V _{GS} , I _D = 50μA	0.65	0.95	1.2	
Gate-body leakage	I _{GSS}	V _{DS} = 0V, V _{GS} = ±8V			±100	nA
Zero gate voltage drain current	I _{DSS}	V _{DS} = 20V, V _{GS} = 0V			1	μA
Drain-source on-resistance ^a	r _{DS(on)}	V _{GS} = 4.5V, I _D = 3.6A		0.045	0.060	Ω
		V _{GS} = 2.5V, I _D = 3.1A		0.070	0.115	
Forward transconductance ^a	g _{fs}	V _{DS} = 5V, I _D = 3.6A		8		S
Diode forward voltage	V _{SD}	I _S = 0.94A, V _{GS} = 0V		0.76	1.2	V
Dynamic						
Total gate charge	Q _g	V _{DS} = 10V, V _{GS} = 4.5V, I _D = 3.6A		4.0	10	nC
Gate-source charge	Q _{gs}			0.65		
Gate-drain charge	Q _{gd}			1.5		
Input capacitance ^b	C _{iss}	V _{DS} = 10V, V _{GS} = 0V, f = 1MHz		300		pF
Output capacitance ^b	C _{oss}			120		
Reverse transfer capacitance ^b	C _{rss}			80		
Switching^b						
Turn-on delay time	t _{d(on)}	V _{DD} = 10V, R _L = 5.5Ω, I _D ≈ 3.6A, V _{GEN} = 4.5V, R _g = 6Ω		7	15	ns
Rise time	t _r			55	80	
Turn-off delay time	t _{d(off)}			16	60	
Fall time	t _f			10	25	

Notes :

- a. Pulse Test : Pulse width ≤ 300μs, duty cycle ≤ 2%.
- b. These parameters have no way to verify.

Typical Characteristics

Output Characteristics

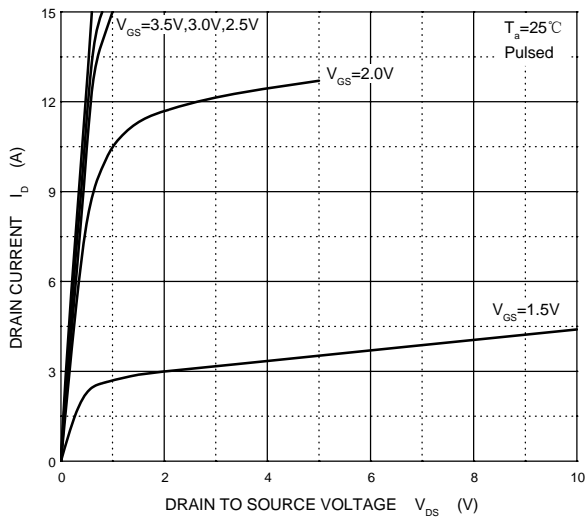

Transfer Characteristics

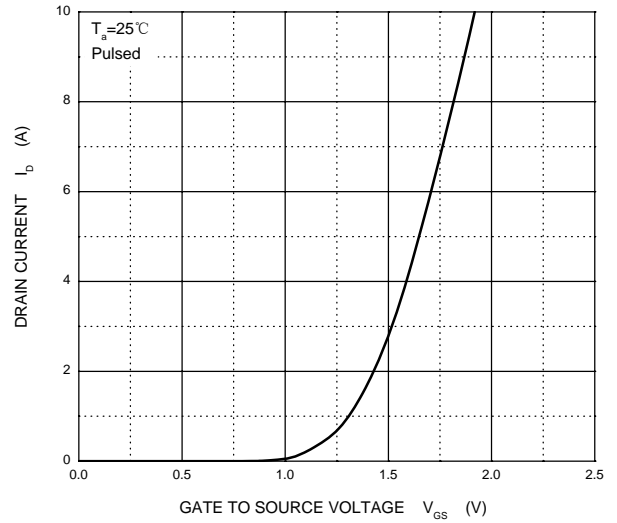

$R_{DS(ON)}$ — I_D

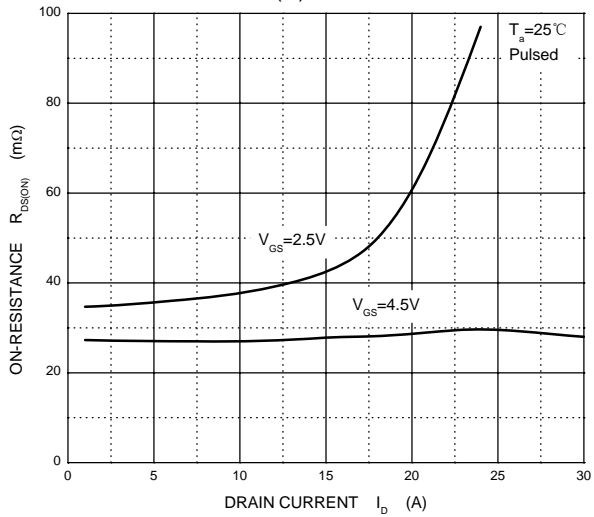

$R_{DS(ON)}$ — V_{GS}

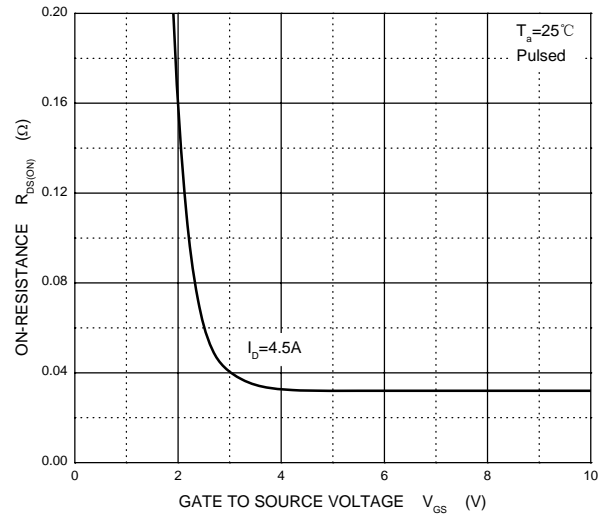



PACKAGE OUTLINE

Plastic surface mounted package; 3 leads

SOT-23

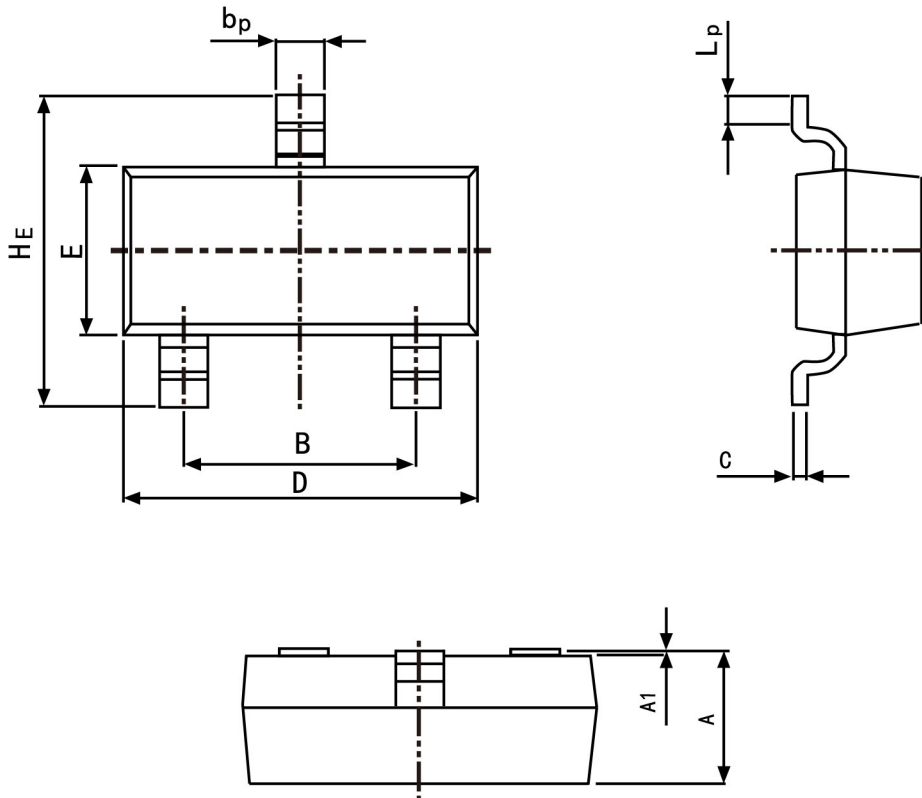

Symbol	Dimension in Millimeters	
	Min	Max
A	0.95	1.40
B	1.78	2.04
b_p	0.35	0.50
C	0.08	0.19
D	2.70	3.10
E	1.20	1.65
HE	2.20	3.00
A_1	0.100	0.013
L_p	0.20	0.50