

YH CARBON FILM RESISTORS DATE: 2009-4-29

广州市缘和电子有限公司

承認書

(APPROVAL SHEET)

客戶名稱 Client	
品名 Description	CARBON FILM RESISTORS
CF1/6W	CF1/6W-CF5W ±5%
料號 Part No	
備注 Remark	

製造廠商:

使用廠商: _____

核準 Approval	校對 Check By	主辦 Prepared By
李培元	李培元	

核準 Approval	校對 Check By	主辦 Prepared By

公 司 章	
-------------	--

公 司 章	
-------------	--

YH CARBON FILM RESISTORS DATE: 2009-4-29

1. GENERAL INSTRUCTION:

1-1. SCOPE

This specification applies to the Carbon Film Resistor MADE BY LGE ELECTRONICS IND. CORP.

1-2 .CLASSIFICATION

Type number is described as follows.

CF	1/4W	T	1M OHM	J (±5%)
CLASS	POWER RATING	SHAPE	NOMINAL RESISTANCE VALUE	TOLERANCE

2. NOMINAL RESISTANCE:

The nominal resistance shall be the resistance marked on the resistor body and identified, as a rule, in units, Ω , $K\Omega$, $M\Omega$.

3. NOMINAL RESISTANCE TOLERANCE.

The nominal resistance tolerance is represented in one capital letter selected from G($\pm 2\%$), J($\pm 5\%$), K($\pm 10\%$), M($\pm 20\%$).

4. RATING:

CF(CARBON FILM FIXED RESISTORS)

STYLE	MAX WORKING	MAX OVERLOAD	RESISTANCE VALUE RANGE
CF1/6W / CF1/8W	200V	400V	0.1 Ω ~ 22M Ω
CF1/4W / CF1/4WS	300V	600V	0.1 Ω ~ 22M Ω
CF1/2W / CF1/2WS	350V	700V	0.1 Ω ~ 22M Ω
CF1W / CF1WS	500V	1000V	0.1 Ω ~ 22M Ω
CF2W / CF2WS	500V	1000V	0.1 Ω ~ 22M Ω
CF3W / CF3WS	600V	1000V	0.1 Ω ~ 22M Ω
CF5W / CF5WS	600V	1000V	0.1 Ω ~ 22M Ω

4-1. POWER RATING

YH CARBON FILM RESISTORS

DATE: 2009-4-29

power rating is defined as maximum power rating continuously applied under ambient temperature at 70°C. when the ambient temperature exceeds 70°C, use chart 1.

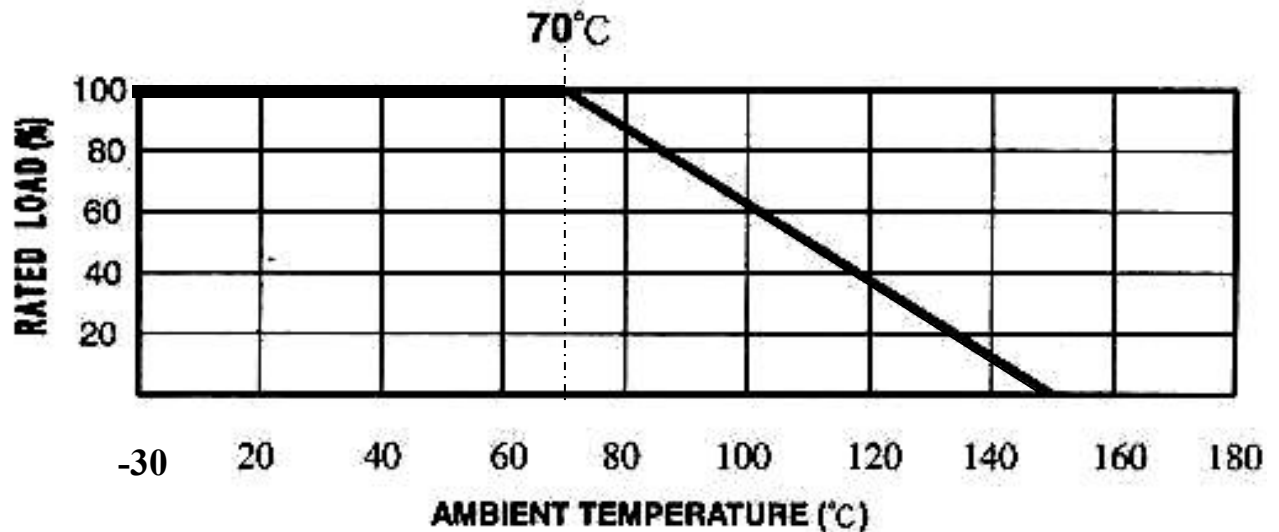

4-2. RATED VOLTAGE

Rated voltage is defined as the DC or (AC effective Value at commercial frequency example 50 C/S, 60 C/S) Voltage when rated power is applied and can be calculated

By the following EQUATION $E = \sqrt{P \cdot R}$

E=RATED VOLTAGE

P=RATED POWER (WATTS)

R=NOMINAL RESISTANCE VALUE (OHM)

When the calculated rated voltage exceeds the Maximum usable voltage flue shown in CHART 1, the Maximum usable voltage is defined as the voltage According to the power-decreasing curve shown in CHART1.

ITEM (STANDARD)	PERFORMANCE AND/OR QUALITY ACCEPTANCE	TEST METHOD
Resistance value Vs Temperature Characteristics	For $R_x < 100K\Omega$ $+350 \sim -500PPM/^\circ C$ $100K\Omega \leq R_x \leq 1M\Omega$ $0 \sim -700PPM/^\circ C$ $1 M\Omega < R_x$ $0 \sim -1500PPM/^\circ C$	JIS-C-5202 5.2 Measure resistance (R_o ohm) at room Temperature(T_o °C) Measure again the same at 100°C Higher than room temperature $PPM = \frac{R - R_o}{R_o} * \frac{10^6}{(T_o + 100) - T_o}$

YH CARBON FILM RESISTORS

DATE: 2009-4-29

Short time overload	The resistance variation shall be within $\pm(0.75\% + 0.05 \text{ ohm})$ and there shall be no mechanical breakage	JIS-C-5202 5.5 Apply DC voltage 2.5times the rated Voltage for 5 seconds The leave at room temperature for 30 Minutes then measure MAX overload Voltage 0.50W – 700V (DC)
ITEM (STANDARD)	PERFORMANCE AND/OR QUALITY ACCEPTANCE	TEST METHOD
Insulation resistance	1000M ohm or more	JIS-C-5202 5.6 In V-BLOCK Lay the resistor on 90° angle metal V Block apply 100VDC between resistor Lead and V block for one Minute And Measure
Voltage endurance	The resistance variation shall be within $\pm(2\% + 0.05\text{ohm})$ and there shall be no mechanical breakage	JIS-C-5202 5.7 Icy the resistor on the 90° angle metal V Block and apply reamed AC voltage for One Minute. Test voltage 0.25W – 500V (AC) 0.50W –700V(AC)
Intermittent overload	Resistance variation shall be Within $\pm(2.00\% + 0.05\text{ohm})$	JIS-C-5202 5.8 Apply AC voltage 4 times the rated voltage for 1 second and rest for 25 seconds and Repeat this cycle for 10000 \pm 200times leave resistor 30 minutes at room temperature after test and measure Maximum voltage for intermittent Overload.0.50W-700V(AC)
Terminal strength	Resistance variation shall be within $\pm(0.5\% + 0.05\text{ohm})$ also there shall be on mechanical breakage	Pull test: apply 2.5kg force to the lead in the direction of lead axislor30 \pm 5 seconds.
Heat resistively Against soldering	Resistance variation shall be within $\pm(1.0\%+0.05\text{ohm})$ also there shall be on mechanical breakage	JIS-C-5202 7.10 Dip the lead in to a solder bath having a Temperature of 350°C \pm 10°C up to 4 \pm 0.8mm from the body of the resistor at room temperature 3 hours after ,then Measure
Solder ability	More than 95% of the surface of the lead shall be covered by new solder after the leads are dipped in the Solder	JIS-C-5202 6.5 Dip the lead in to a solder bath having a Temperature of 260°C \pm 5°C up to 4 \pm 0.8mm from the body of the resistor and hold it for 5 \pm 0.5seconds then inspect
Humidity load test	Resistance variation be Within $\pm(3.0\% + 0.05\text{ohm})$ Also there shall be mo mechanical breakage	JIS-C-5202 7.9 In temperature chamber having temperature 40°C \pm 2°C,relative humidity 90 – 95%, Apply rated voltage 1.5hour and shut voltage 0.5 hour repeat this cycle for 1000 hours, leave in room temperature for lhour

YH CARBON FILM RESISTORS

DATE: 2009-4-29

		after test, then measure
Load life test	The variation of the resistance Shall be within $\pm (3\%+0.05\text{ohm})$ Also there shall be no mechanical Breakage	JIS-C-5202 7.10 In the constant temperature chamber having Temperature $70^{\circ}\text{C} \pm 2^{\circ}\text{C}$, apply rated Dc voltage for 1.5hour and shut voltage for 0.5 hour and repeat thin cycle for 1000 hours, leave in room temperature 1hour after test, then measure

5. Marking

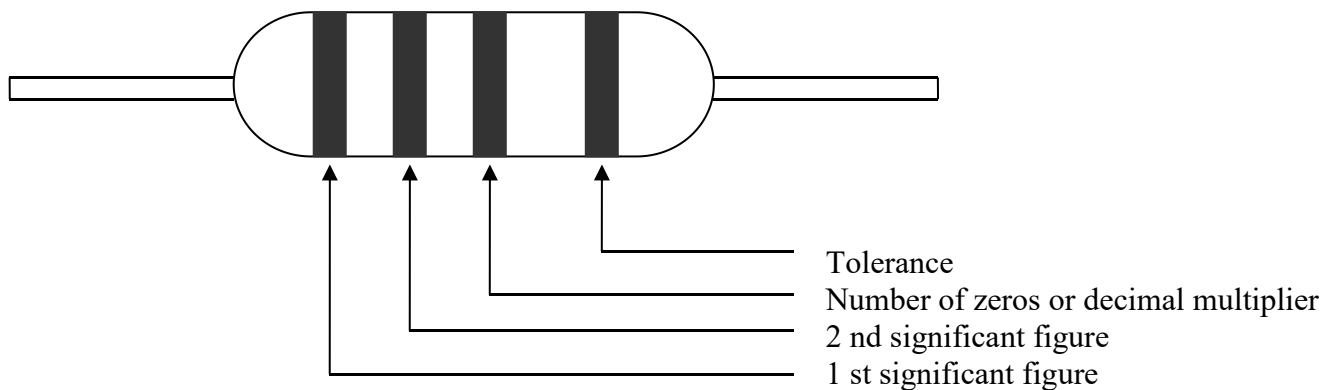

Color refer

Color	1 st Band	2 nd Band	3 rd Band	4 th Band
Black	0	0	10^0	
Brown	1	1	10^1	
Red	2	2	10^2	$\pm 2.0\%$
Orange	3	3	10^3	
Yellow	4	4	10^4	
Green	5	5	10^5	
Blue	6	6	10^6	
Violet	7	7	10^7	
Grey	8	8	10^8	
White	9	9	10^9	
Gold			10^{-1}	$\pm 5.0\%$
Silver			10^{-2}	$\pm 10.0\%$

6. Construction and Dimension

6-1. Construction

- a. Tinned Copper Wire .
- b. Tinned Iron Caps.
- c. Carbon Film
- d. Ceramic Rod
- e. Epoxy Resin.

YH CARBON FILM RESISTORS

DATE: 2009-4-29

f. Color Code

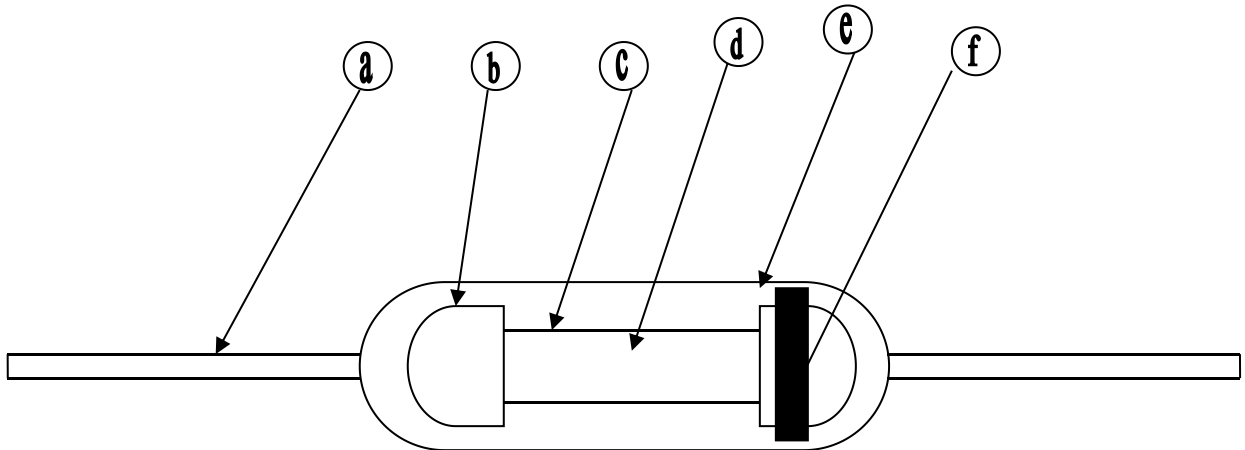

6-2 Dimensions

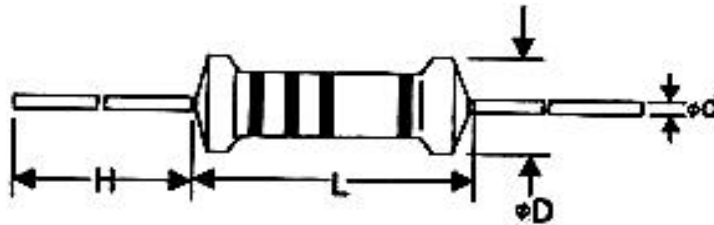
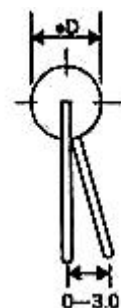
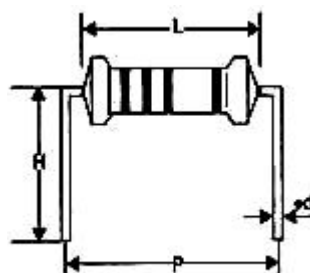

TABLE:

WATTS	L	D	H	d ± 0.05mm	PULLING (Kg)
1/6W 1/8W 1/16W	3.3±0.3	1.8±0.3	28±2.0	0.33	2.5Kg - 30S
1/4WS					
1/4W	6.0±0.5	2.3±0.3	27.0±2.0	0.33	2.5Kg - 30S
1/2WS					
1/2W	8.0±0.5	2.5±0.3	26.0±2.0	0.40	2.5Kg - 30S
1WS					
1W	11.0±1.0	3.5±0.5	25.0±2.0	0.45	3Kg - 30S
2WS					
2W	15.0±1.0	4.0±0.5	33.0±2.0	0.50	5Kg - 30S
3WS					
3W	17.0±1.0	6.0±0.5	32.0±2.0	0.60	5Kg - 30S
5WS					
5W	24.0±1.0	8.0±1.0	28.0±2.0	0.70	5Kg - 30S

7. FORMED DIMENSIONS

7-1. M - TYPE



YH CARBON FILM RESISTORS

DATE: 2009-4-29

WATTS	DIMENSIONS (mm)				
	L	P±1.0	D	d±0.05	H±1.0
1/6W/1/8W/1/16W /1/4WS	3.3±0.3	6	1.8±0.3	0.33	6.0
1/4W/1/2WS	6.0±0.5	10	2.3±0.3	0.33	10
1/2W/1WS	8.0±0.5	12.5	2.5±0.3	0.40	10
1W/2WS	11.0±1.0	15	3.5±0.5	0.45	12.5
2W/3WS	15.0±1.0	20	4.0±0.5	0.50	15.0
3W/5WS	17.0±1.0	23	6.0±0.5	0.60	15.0
5W	24.0±1.0	33	8.0±1.0	0.70	15.0

7-2 . MB – TYPE

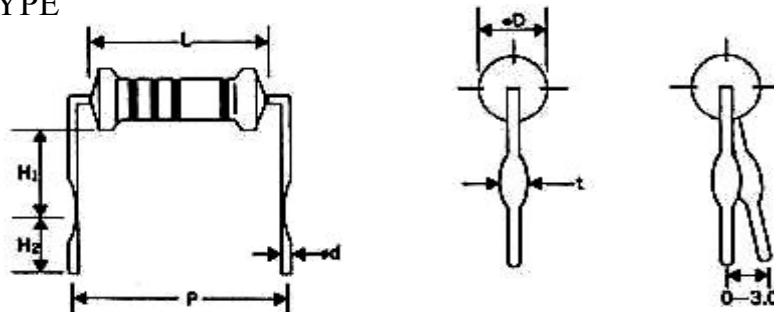

WATTS	DIMENSIONS (mm)						
	L	P±1.0	D	d±0.05	H1±1.0	H2±1.0	t±0.2
1/2W/1WS	8.0±0.5	12.5	2.5±0.3	0.60	6.0	5.0	1.0
1W/2WS	11.0±1.0	15	3.5±0.5	0.60	6.0	5.0	1.3
2W/3WS	15.0±1.0	20	4.0±0.5	0.60	10.0	5.0	1.3
3W/5WS	17.0±1.0	23	6.0±0.5	0.70	10.0	5.0	1.3
5W	24.0±1.0	33	8.0±1.0	0.70	10.0	5.0	1.3

7 – 3. F – TYPE

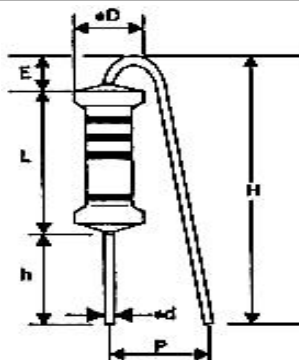

WATTS	DIMENSIONS (mm)						
	L	P±1.0	D	d±0.05	h±1.0	H±1.0	E _{max}
1/4W/1/2WS	6.0±0.5	6	2.3±0.3	0.33	5.0	14	3
1/2W/1WS	8.0±0.5	6	2.5±0.3	0.40	5.0	18	3.5
1W/2WS	11.0±1.0	6	3.5±0.5	0.45	5.0	20	3.5
2W/3WS	15.0±1.0	6	4.0±0.5	0.50	5.0	25	3.5
3W/5WS	17.0±1.0	6	6.0±0.5	0.60	5.0	30	3.5

YH CARBON FILM RESISTORS DATE: 2009-4-29

7-4. FK2-TYPE, FK1-TYPE AND FKK-TYPE

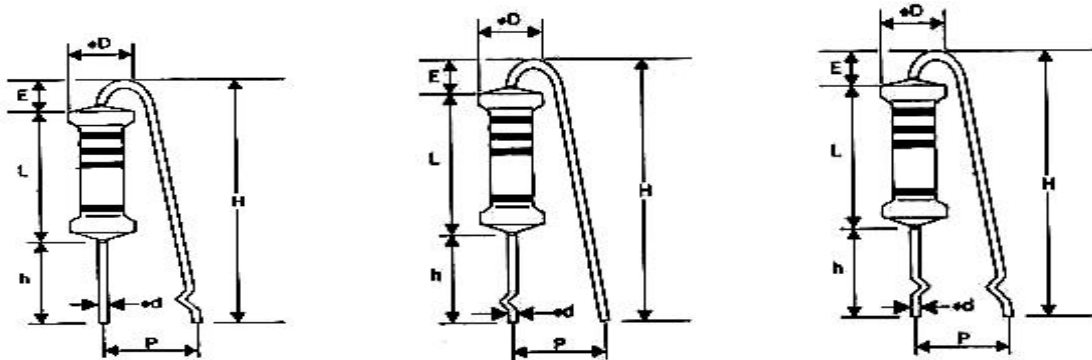

WATTS	DIMENSIONS(mm)						
	L	P±1.0	D	d±0.02	h+1/-0	H±1.0	E _{max}
1/2W/1WS	8.0±0.5	6	2.5±0.3	0.40	5	18	3.5
1W/2WS	11.0±1.0	6	3.5±0.5	0.45	5	20	3.5
2W/3WS	15.0±1.0	6	4.0±0.5	0.50	5	25	3.5
3W	17.0±1.0	6	6.0±0.5	0.60	5	30	3.5

8. Taping Dimensions

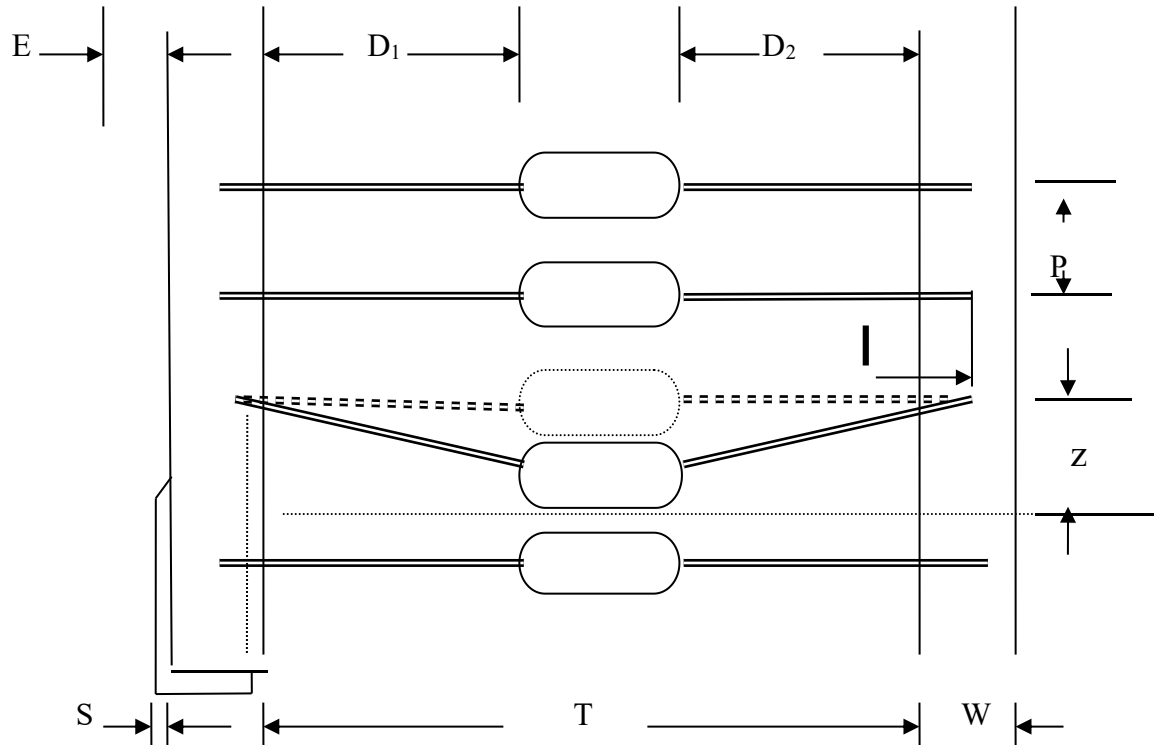

WATTS	Type	T	p±0.5	W±0.5	D1-D2 MAX	E MAX	Z MAX	S MAX	I MAX
1/6W/1/8W	T- 26	26±1.5	5	6	0.8	0	1.2	0.8	3.2

YH CARBON FILM RESISTORS

DATE: 2009-4-29

1/16W/1/4WS	T- 52	52±1.5	5	6	0.8	0	1.2	0.8	3.2
1/4W 1/2WS	T- 26	26±1.5	5	6	0.8	0	1.2	0.8	3.2
	T- 52	52±1.5	5	6	0.8	0	1.2	0.8	3.2
1/2W/1WS	T- 52	52±1.5	5	6	0.8	0	1.2	0.8	3.2
1W/2WS	T- 73	73±1.5	5	6	0.8	0	1.4	0.8	3.2
2W/3WS	T- 73	73±1.5	10	6	0.8	0	1.4	0.8	3.2
3W/5WS	T- 73	73±1.5	10	6	0.8	0	1.4	0.8	3.2
5W	T- 73	73±1.5	10	6	0.8	0	1.4	0.8	3.2

9 . PACKING

9 - 1. TAPING TYPE

LABEL SPECIFICATION

1. TYPE
2. WATTS TOLERANCE
3. RESISTANT QUANTITY LIEAN-GIMN ENTERPRISE CO, LTD
4. P/N
5. LOT NO.

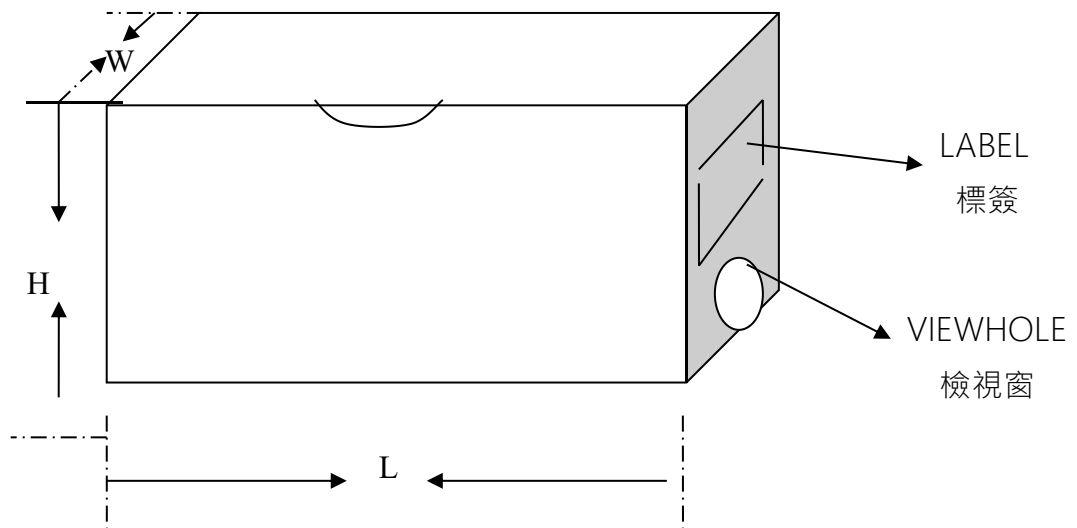

TYPE	WATTS	W(mm)	H(mm)	L(mm)	Q:TY(pcs)
T-26	1/6W 1/8W 1/16W 1/4WS	50	72	260	5000
	1/4W/ 1/2WS	53	103	260	5000
T-52	1/6W / 1/8W 1/16W 1/4WS	73	72	267	5000
	1/4W/ 1/2WS	73	102	267	5000

YH CARBON FILM RESISTORS

DATE: 2009-4-29

	1/2W/ 1WS	73	57	255	1000
T-73	1W/ 2WS	92	83	267	1000
	2WS/ 3WS	92	89	267	1000
	3W/5WS	92	83	267	500
	5W	92	83	267	500

9 - 2. BULK

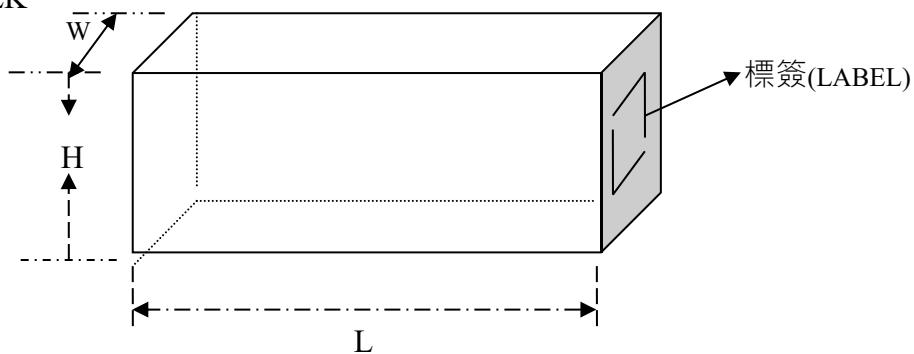

YH CARBON FILM RESISTORS DATE: 2009-4-29

WATTS		TYPE	L(mm)	W(mm)	H(mm)	POLY BOG	BOX(pcs)
1/6W 1/8W	1/16W 1/4WS	P	250	140	67	1000	20000
		MOLDING					
1/4W	1/2WS	P	250	140	67	500	10000
		MOLDING					
1/2W	1WS	P	250	140	67	500	5000
		MOLDING					
1W	2WS	P	250	140	67	200	2000
		MOLDING					
2W	3WS	P	250	140	67	200	1000
		MOLDING					
3W/5WS		P	250	140	67	100	1000
		MOLDING					
5W		P	250	140	67	100	1000
		MOLDING					