

REV.	DESCRIPTION OF REVISIONS	APPR.	CHKD.	DRAW.	DATE
△	Original reversion	lucky	lucky	Roy	2021/12/06
△	Change product model No.	lucky	lucky	Roy	2023/10/25

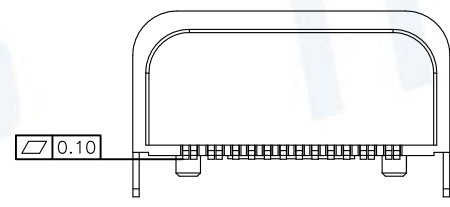

PIN	SIGNAL NAME	PIN	SIGNAL NAME
A1	GND	B12	GND
A4	VBUS	B9	VBUS
A5	CC1	B8	SBU2
A6	DP1	B7	DN2
A7	DN1	B6	DP2
A8	SBU1	B5	CC2
A9	VBUS	B4	VBUS
A12	GND	B1	GND

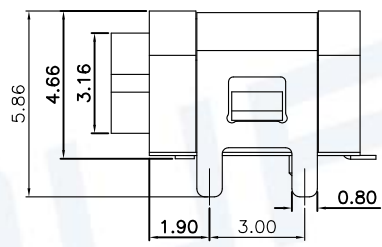
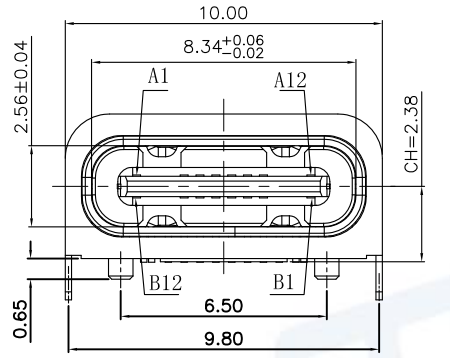
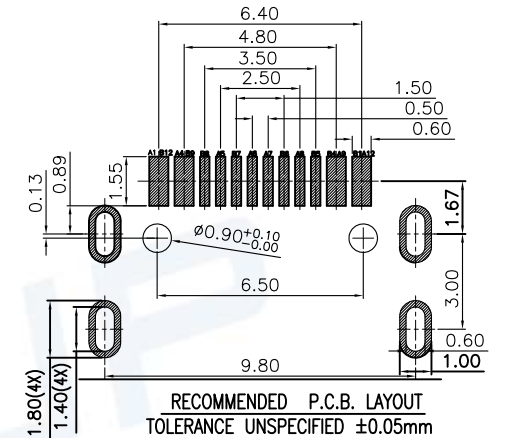
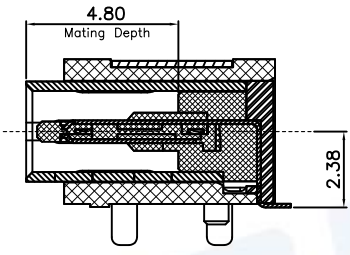
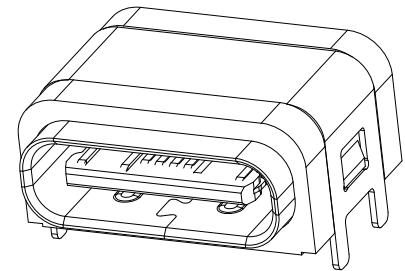
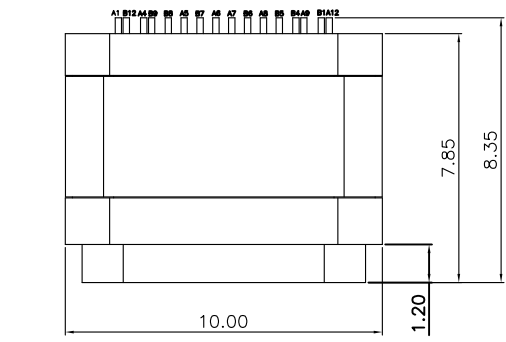
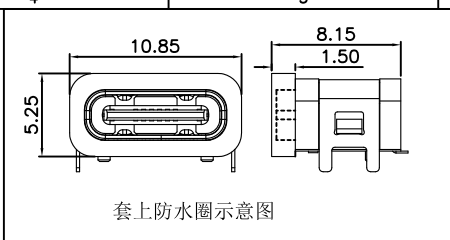
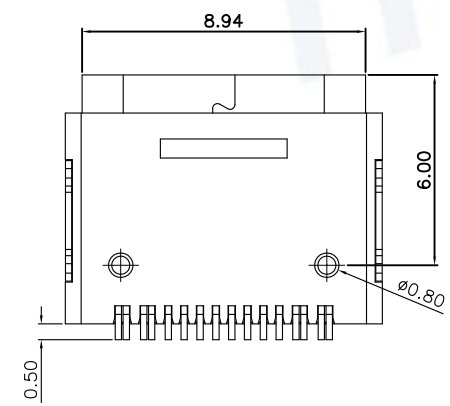

NOTE:

- MECHANICAL:**
 - 1-1 Insertion force: 5~20N
 - 1-2 Extraction force: 8~20N
Extraction force: 10000 CYCLES 6~20N
 - 1-3.FREQUENCE:500±50 CYCLES/HOUR,10000 CYCLES;
- ELECTRICAL CHARACTERISTICS:**
 - 2-1. CURRENT RATING:
VBUS Pins (A4,A9,B4,B9): 5.0A.
Vconn(B5) : 1.25A
Other All Pins 0.25A
 - 2-2. INITIAL CONTACT RESISTANCE:40mΩ Max.
 - 2-3. INSULATION RESISTANCE:100MΩ MIN
 - 2-4. WITHSTANDING VOLTAGE:100V AC,1 MINUTE;
- ENVIRONMENTAL**
TEMPERATURE RANGE: -40°C TO +85°C.
- WATER PROOFNESS:**THIS PRODUCT IS BASED ON IPX7.

ITEM	PART NAME	Q'TY	MATERIAL	FINISH
1	Molding	1	THERMOPLASTIC	Black, UL94V-0
2	SHELL HOUSING	1	THERMOPLASTIC	Black, UL94V-0
3	CONTACT	16	COPPER ALLOY	Contact area: Au 3u"
4	SHELL	1	STAINLESS STEEL	Ni plated over all
5	MID-PLATE	1	STAINLESS STEEL	Cleaning
6	O-ring	1	Silicone Rubber	Black,

Unless otherwise specified, other tolerance are:

X	±0.40	X'	±5'
X.X	±0.30	X.X'	±4'
X.XX	±0.20	X.XX'	±3'
X.XXX	±0.10	X.XXX'	±2'

MUP MUP INDUSTRIAL CO.,LTD.

NAME: USB Type C Single-Row SMT on Board Receptacle

MODEL NO: MUP-U20409-02

TYPE: 16P & Single-Row SMT on board & Waterproof

PROJ.	UNIT	SCALE	DRAW	Roy	2021/12/06	DWG NO.:
①	mm	1:1	CHECKED	lucky	2021/12/06	DWG-U20409-02-01
CUSTOMER DRAWING			APPROVAL	lucky	2021/12/06	SHEET
					1/3	REVISION
						2



REV.	DESCRIPTION OF REVISIONS	APPR.	CHKD.	DRAW.	DATE
△	Original reversion	lucky	lucky	Roy	2021/12/06
△	Change product model No.	lucky	lucky	Roy	2023/10/25

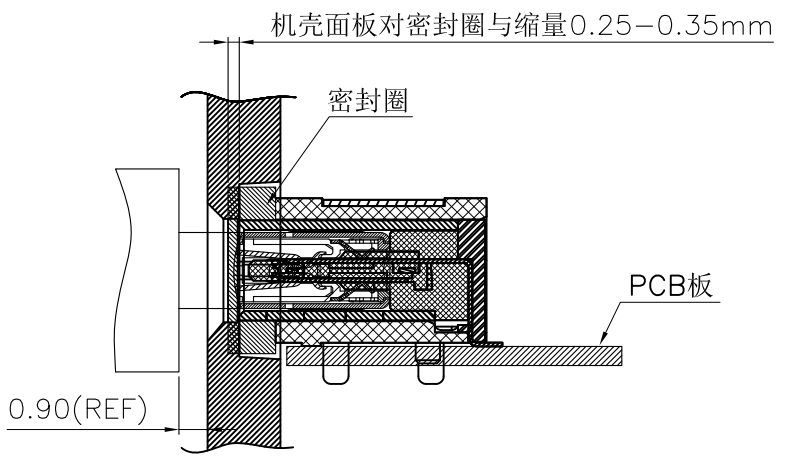

组装面板后公母头对插示意图

机壳面板设计尺寸

建议密封方式

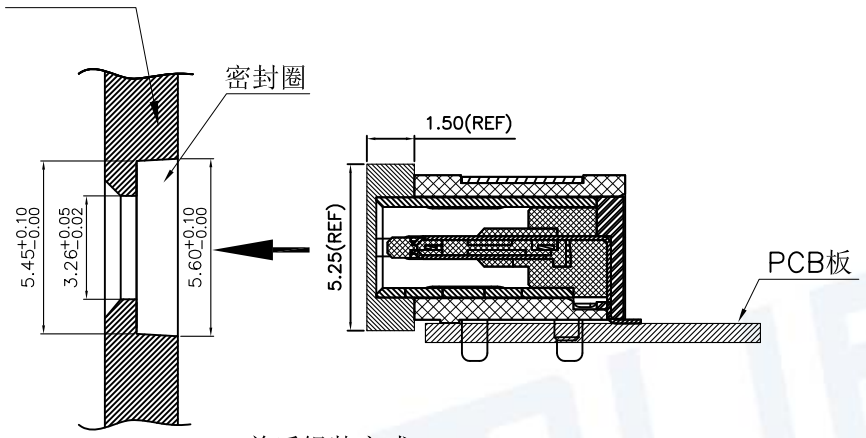

前后组装方式

O_ring PRAT NO.: HP-1014-001

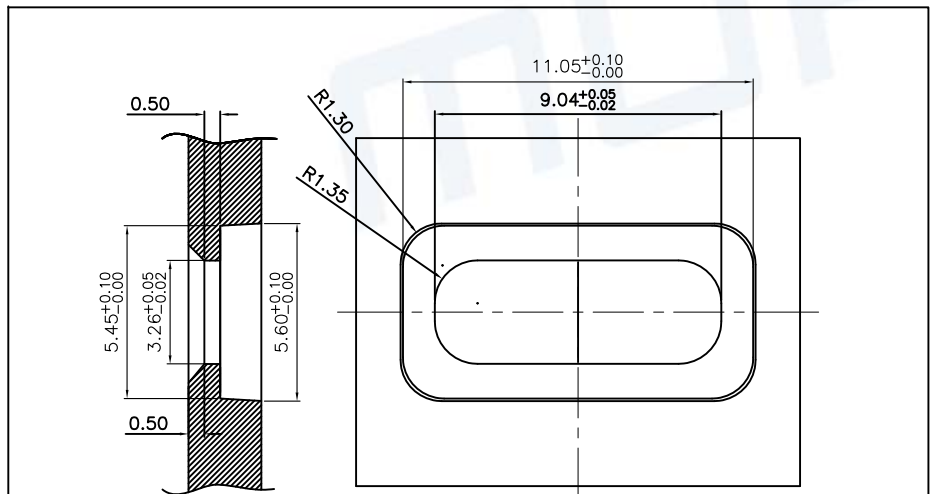
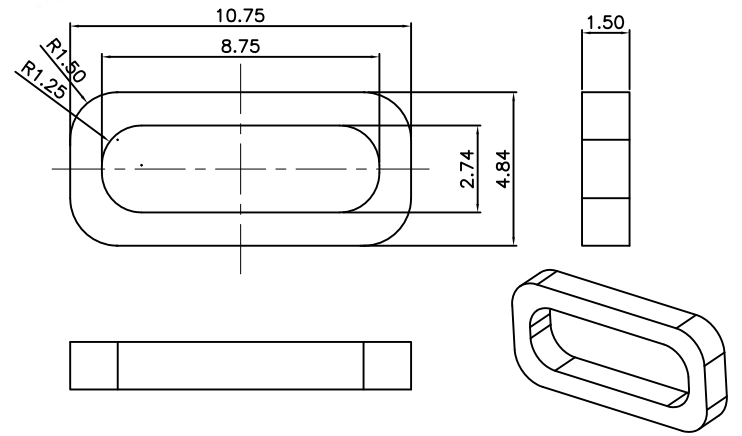

建议机壳面板设计尺寸
(以上尺寸仅供参考)

Unless otherwise specified, other tolerance are:		MUP MUP INDUSTRIAL CO.,LTD.			
X	±0.40	X'	±5'	NAME: USB Type C Single-Row SMT on Board Receptacle	
X.X	±0.30	X.X'	±4'	MODEL NO: MUP-U20409-02	
X.XX	±0.20	X.XX'	±3'	TYPE: 16P & Single-Row SMT on board & Waterproof	
X.XXX	±0.10	X.XXX'	±2'	DRAW Roy 2021/12/06	
PROJ.	UNIT mm	SCALE 1:1	CHECKED lucky 2021/12/06	DWG NO.: DWG-U20409-02-01	
CUSTOMER DRAWING			APPROVAL lucky 2021/12/06	SHEET 2/3	REVISION 2



REV.	DESCRIPTION OF REVISIONS	APPR.	CHKD.	DRAW.	DATE
△	Original reversion	lucky	lucky	Roy	2021/12/06
△	Change product model No.	lucky	lucky	Roy	2023/10/25

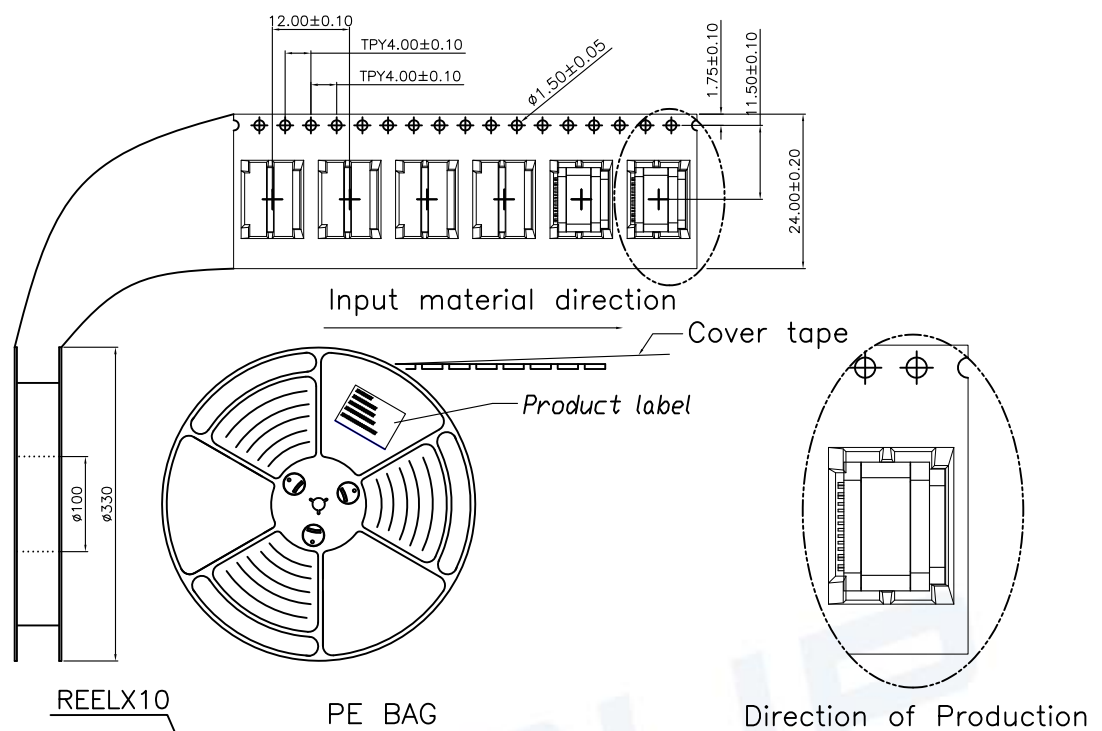

NOTES

1. NUMBER OF CONNECTORS:900PCS/REEL
2. LEAD TAPE LENGTH

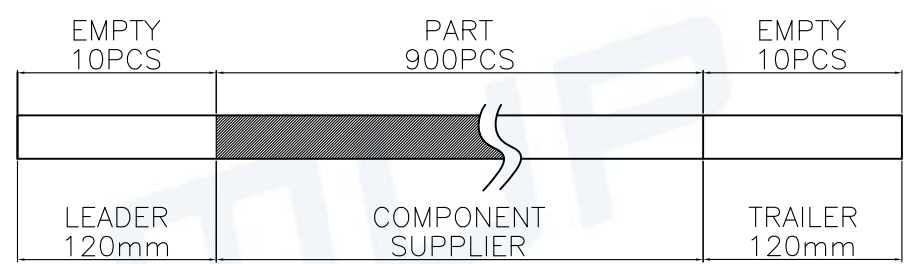

3. QUANTITY:9000/CARTON
4. WEIGHT :
 - 4.1 NET WEIGHT : 6.95 Kg
 - 4.2 GROSS WEIGHT : 12.0 Kg
- 5.Meas:350Lx350Wx315H mm

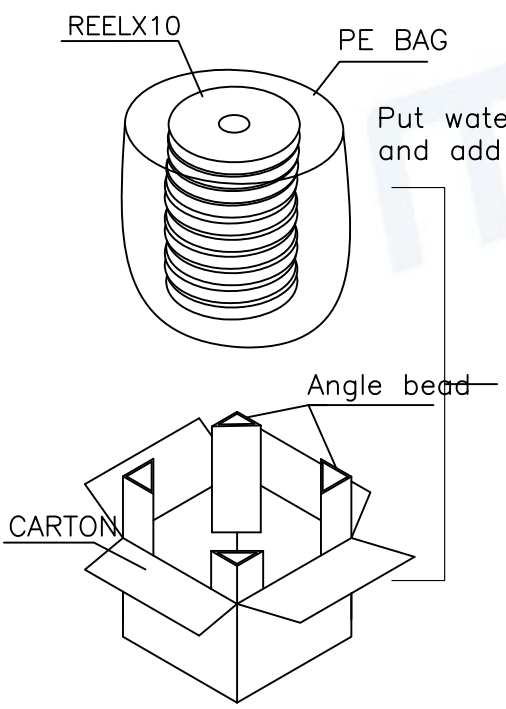

Put waterproof PE bag inside the box and add two desiccants.

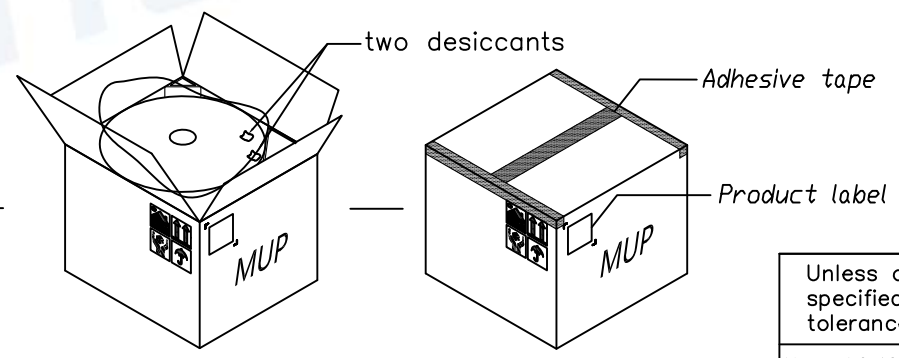

Unless otherwise specified, other tolerance are:			MUP INDUSTRIAL CO.,LTD.									
X	±0.40	X'				±5'	NAME :	USB Type C Single-Row SMT on Board Receptacle				
X.X	±0.30	X.X'	±4'	MODEL NO:	MUP-U20409-02							
X.XX	±0.20	X.XX'	±3'	TYPE :	16P & Single-Row SMT on board & Waterproof							
X.XXX	±0.10	X.XXX'	±2'	PROJ.	UNIT	SCALE	DRAW	Roy	2021/12/06	DWG NO.:	DWG-U20409-02-01	
					mm	1:1	CHECKED	lucky	2021/12/06	SHEET		REVISION
CUSTOMER DRAWING			APPROVAL	lucky	2021/12/06	3/3	2					

