



UIC809

CMOS IC

MICROPROCESSOR RESET CIRCUITS

DESCRIPTION

The UTC **UIC809** series are resetting circuits which can monitor power supplies especially in microprocessor based systems.

In normal operation, the UTC **UIC809** series can assert a reset under any of the following situation: the power supply drops below a designated reset threshold level (which is available for 3V or 3.3V or 5V system) is forced low.

There is an internal active low $\overline{\text{RESET}}$ output which has already been guaranteed to remain asserted for at 140ms least while V_{CC} rises above the designed threshold level.

FEATURES

- * Voltage monitor for 3V or 3.3V or 5V power supplies
- * Valid $\overline{\text{RESET}}$ remains with V_{CC} as low as 1V
- * Typical supply current: 5 μ A
- * Fixed 140ms minimum reset pulse width
- * With Manual reset input
- * Push-Pull $\overline{\text{RESET}}$ Active Low Output

ORDERING INFORMATION

Ordering Number		Package	Pin Assignment			Packing
Lead Free	Halogen Free		1	2	3	
UIC809Lx-AE2-3-R	UIC809G-x-AE2-3-R	SOT-23-3	GND	$\overline{\text{RESET}}$	V_{CC}	Tape Reel

Note: Pin Assignment : x: Output Voltage, refer to Marking Information.

<p>UIC809G-x-AE2-3-R</p> <p>(1) Packing Type (2) Pin Assignment (3) Package Type (4) Output Voltage Code (5) Green Package</p>	<p>(1) R: Tape Reel (2) refer to Pin Assignment (3) AE2: SOT-23-3 (4) x: Refer to Marking Information (5) G: Halogen Free and Lead Free, L: Lead Free</p>
--	---

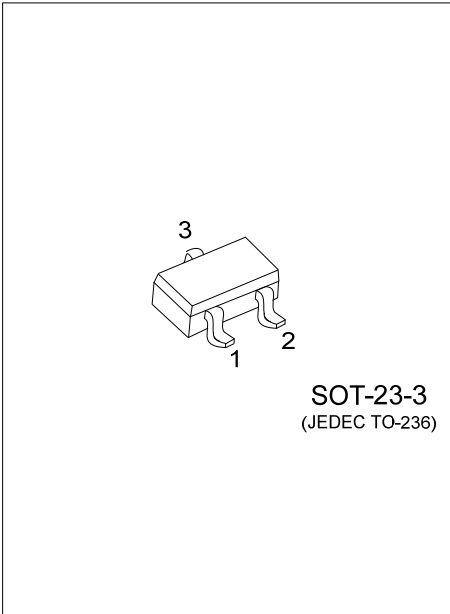

■ MARKING INFORMATION

PACKAGE	VOLTAGE CODE	MARKING
SOT-23-3	B : 2.93V	

■ PIN CONFIGURATION

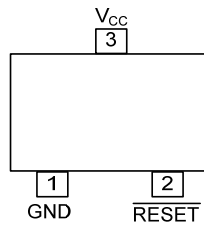

■ PIN DESCRIPTION

No.	PIN NAME	DESCRIPTION
1	GND	Ground
2	$\overline{\text{RESET}}$	This pin will fall low after the V_{CC} 's falling below the reset threshold voltage and it also can remain asserted for at least 140ms min after V_{CC} 's rising upon the reset threshold.
3	V_{CC}	Input of power supply.

■ BLOCK DIAGRAM

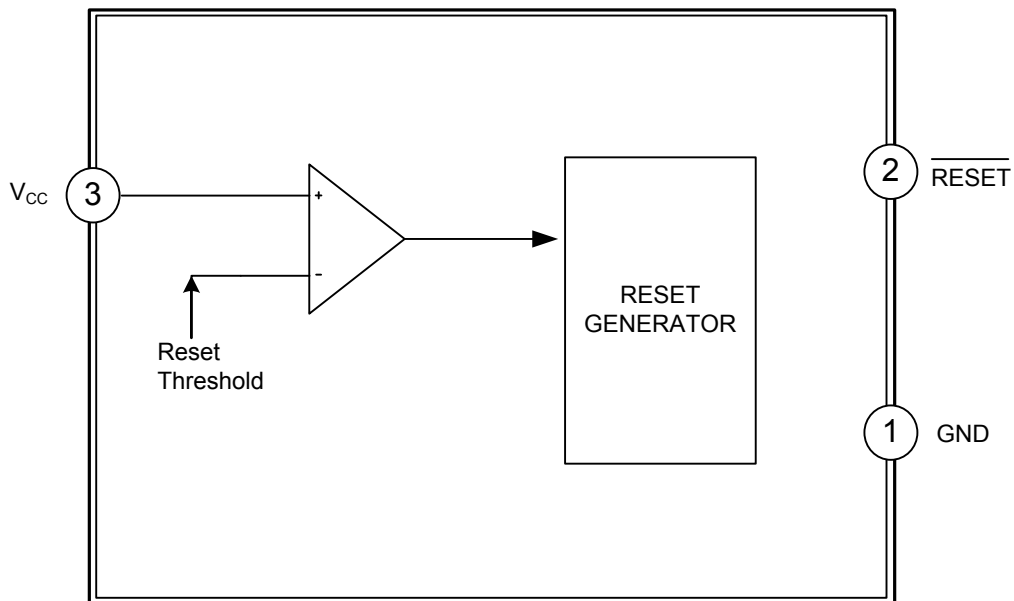

■ FUNCTIONAL DIAGRAM

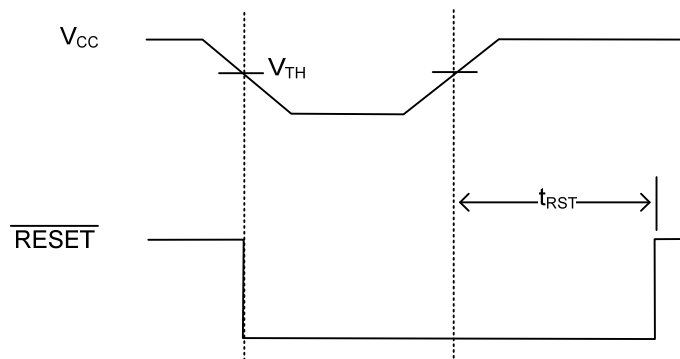

Reset Timing Diagram

■ ABSOLUTE MAXIMUM RATING

PARAMETER	SYMBOL	RATINGS	UNIT
Input Voltage	V_{CC}	-0.3 ~ +6.0	V
Input Current (V_{CC})	I_{IN}	20	mA
Output Current (\overline{RESET})	I_{OUT}	20	mA
Rate of Rise	$V_{CC(RR)}$	100	V/ μ s
Power Dissipation ($T_A = +70^\circ\text{C}$)	P_D	300	mW
Operating Temperature	T_{OPR}	-40 ~ +125	$^\circ\text{C}$
Storage Temperature	T_{STG}	-65 ~ +150	$^\circ\text{C}$

Notes: 1. Absolute maximum ratings are those values beyond which the device could be permanently damaged.

Absolute maximum ratings are stress ratings only and functional device operation is not implied.

2. The device is not guaranteed to function outside its operating rating.

■ ELECTRICAL CHARACTERISTICS

UIC809-B (2.93V) ($V_{CC} = 3.3\text{V}$, $T_A = 25^\circ\text{C}$, unless otherwise specified)

PARAMETER	SYMBOL	TEST CONDITIONS	MIN	TYP	MAX	UNIT
Operating Voltage Range	V_{CC}	$T_A = -40 \sim +85^\circ\text{C}$	1		6	V
Supply Current	I_{CC}	$V_{CC} = 3.3\text{V}$, no load		5	10	μA
Reset Voltage Threshold	V_{TH}		2.85	2.93	3.00	V
Reset Timeout Period	t_{RST}		140	240	560	ms
\overline{RESET} Output Voltage	V_{OH}	$I_{SOURCE} = 500\mu\text{A}$	2.64			V
	V_{OL}	$V_{CC} = V_{TH}$ min, $I_{SINK} = 1.2\text{mA}$			0.3	V
		$V_{CC} > 1\text{V}$, $I_{SINK} = 50\mu\text{A}$, $T_A = -40 \sim +85^\circ\text{C}$			0.3	V



■ TYPICAL APPLICATION CIRCUIT

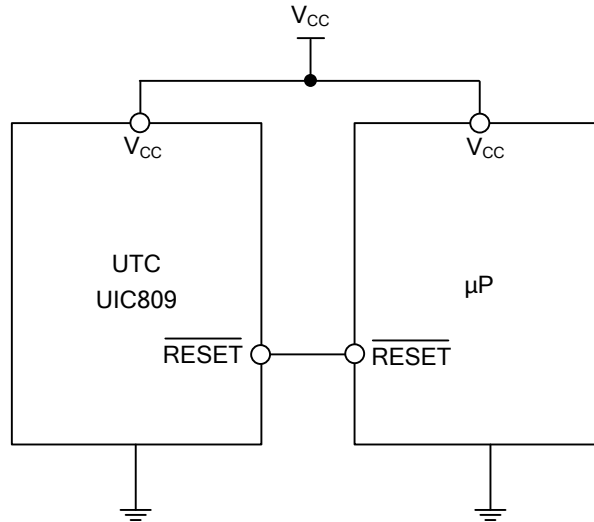

■ APPLICATION INFORMATION

Microprocessor Reset

As soon as V_{CC} falls below the reset threshold voltage, the $\overline{\text{RESET}}$ pin is asserted. But the $\overline{\text{RESET}}$ pin can keep asserted for a period of 140ms after V_{CC} rose above the reset threshold voltage. After a power failure the reset operation can keep the processor being reset and powers up properly.

V_{CC} Transients

The UTC **UIC809** series won't cause a reset typically as this situation: a negative-going transient 125mV below the reset threshold with a duration of 20 μ s or less.

Interfacing to Bidirectional Reset Pins

Connecting a 4.7k Ω resistor in series with the UTC **UIC809** series output and the μ P reset pin can make the UTC **UIC809** series interface with μ Ps with bidirectional reset pins.

$\overline{\text{RESET}}$ Valid at Low Voltage

As the figure below, adding a resistor which is recommended 100k Ω can ensure the $\overline{\text{RESET}}$ output remains low with V_{CC} down to 0V. The size of the resistor should be not too large which will load the output excessively and not too small which can pull-down any stray leakage currents.

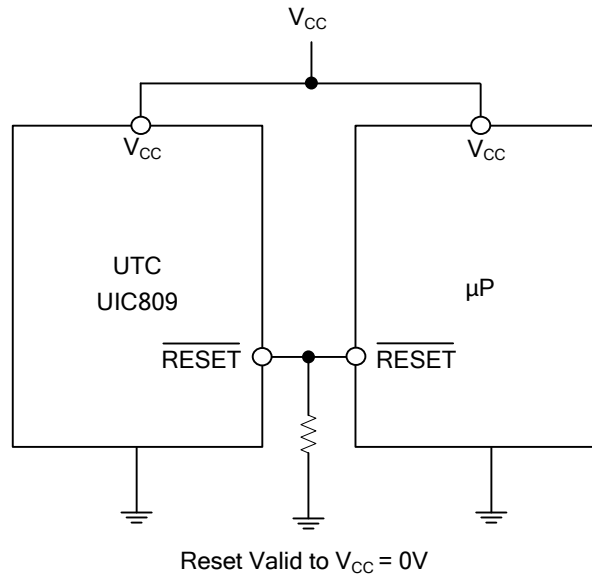

■ TYPICAL CHARACTERISTICS

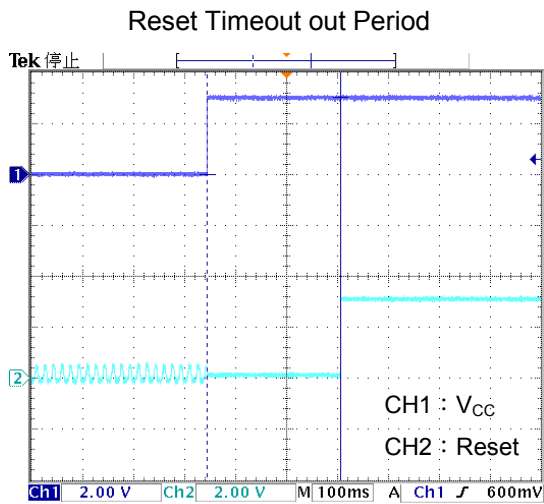

UTC assumes no responsibility for equipment failures that result from using products at values that exceed, even momentarily, rated values (such as maximum ratings, operating condition ranges, or other parameters) listed in products specifications of any and all UTC products described or contained herein. UTC products are not designed for use in life support appliances, devices or systems where malfunction of these products can be reasonably expected to result in personal injury. Reproduction in whole or in part is prohibited without the prior written consent of the copyright owner. UTC reserves the right to make changes to information published in this document, including without limitation specifications and product descriptions, at any time and without notice. This document supersedes and replaces all information supplied prior to the publication hereof.