

# CX-20 SERIES

## Amplifier Built-in Compact Photoelectric Sensor

FX-D1/A1/M1

FX-13

FX-11A

Fiber Sensors

FZ-10

CX-20

CX-30

CX-RVM5/D100/ND300R

EX-10

EX-20

Amplifier Built-in Type

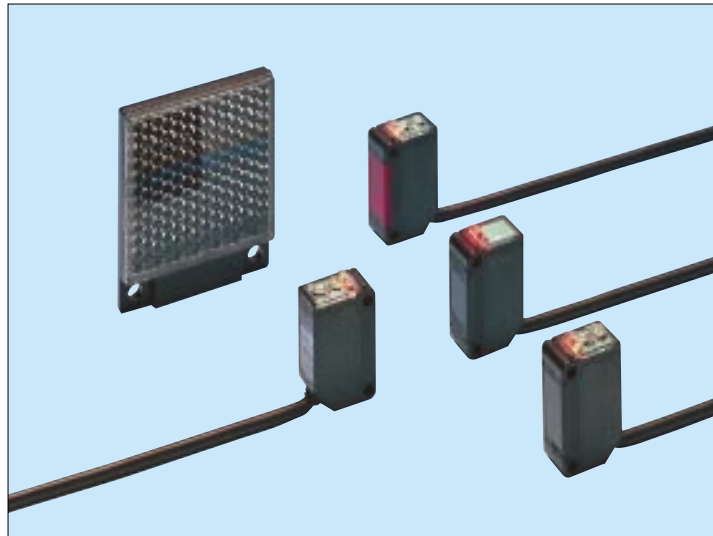

### General Purpose Photoelectric Sensor with Full Basic Performance

Conforming to EMC Directive

#### Compact Size

Just 20mm in depth, 5mm shorter than a conventional model.

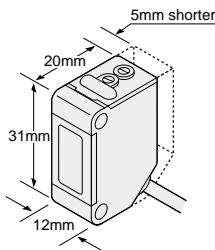

#### Two Sensors Mountable Together

**CX-29** (retroreflective type), **CX-22** and **CX-24** (diffuse reflective type) incorporate an automatic interference prevention function. Hence, two sensors can be mounted close together. (**CX-21**, **CX-23**, **CX-28** or **CX-28IR** do not have this function.)

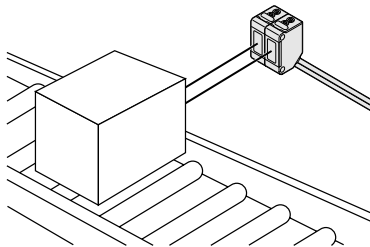

#### Waterproof

The sensor can be hosed down because of its IP67 construction and the non-corrosive stainless steel mounting bracket.

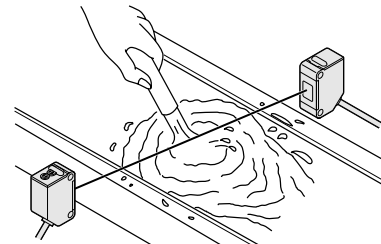

Note: However, take care that if it is exposed to water splashes during operation, it may detect a water drop itself.

#### Strong Light Beam

**CX-21** (thru-beam type) emits a strong light beam which can pass through 20 sheets of copier paper. The sensor incorporates an infrared LED that is strong against dust or dirt.

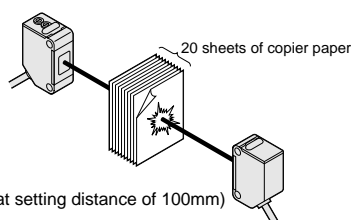

#### Insusceptible to Extraneous Light: CX-23

As the spread of the beam from the **CX-23** emitter is narrow, close mounting of sensors is possible.

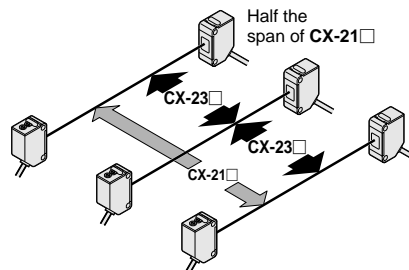

#### Plug-in Connector Type Is Available

Plug-in connector type sensor, which can be easily disconnected for replacement, is available. In case a problem occurs anyone can replace the sensor in a minute.

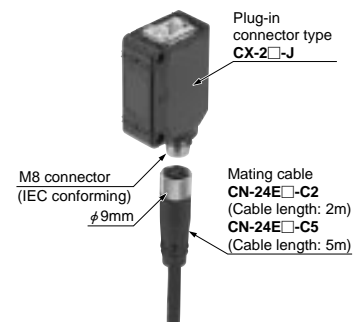

## APPLICATIONS

### Detecting contents in paper pouch

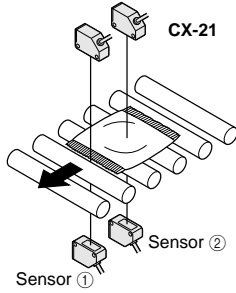

### Detecting shiny refrigerators

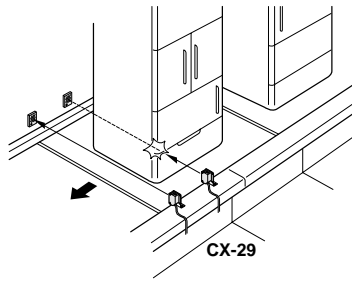

### Detecting rubber sheet

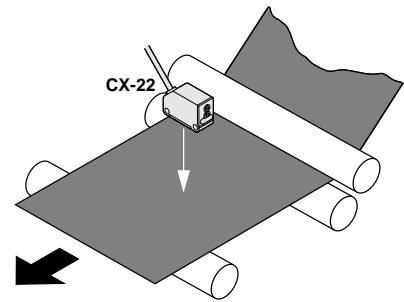

### Detecting pet bottles

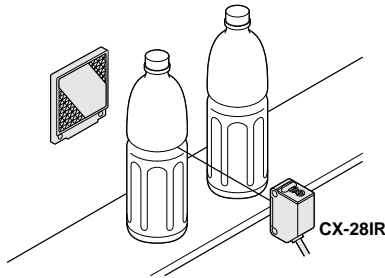

### Transparent objects detectable with CX-28IR□ (Typical examples)

Sensing object	Sensing object size
Glass sheet	□50mm t = 1.0mm
Cylindrical glass	φ50mm ℓ = 50mm t = 2.0mm
	φ100mm ℓ = 50mm t = 2.3mm
Acrylic board	□50mm t = 1.5mm
Styrol (Floppy case)	□50mm t = 1.2mm
Food wrapping film	□50mm t = 10 μm
Cigarette case film	□50mm t = 20 μm
Vinyl sack	□50mm t = 30 μm
Pet bottle	φ55mm
	φ70mm
Glass bin	φ65mm

Reflector setting range: 300 to 500mm  
(with the RF-230 reflector at the optimum)  
(condition (Note))

Each object should pass across the beam at the center between the sensor and the reflector.  
ℓ : Length of cylindrical glasses  
t : Thickness of sensing object

Note: The optimum condition is defined as the condition in which the sensitivity level is set such that the stability indicator just lights up when the object is absent.

## ORDER GUIDE

Type	Appearance	Sensing range	Model No.	Sensing output	Emitting element
NPN output type	Thru-beam	10m	CX-21	NPN open-collector transistor	Infrared LED
		5m	CX-23		
	Retroreflective	0.1 to 3m (Note 1)	CX-29		Red LED
		50 to 1,000mm (Note 1)	CX-28IR		
PNP output type	Thru-beam	10m	CX-21-PN	PNP open-collector transistor	Infrared LED
		5m	CX-23-PN		
	Retroreflective	0.1 to 3m (Note 1)	CX-29-PN		Red LED
		50 to 1,000mm (Note 1)	CX-28IR-PN		
Diffuse reflective	Long sensing range	800mm	CX-22	Infrared LED	
	Short sensing range	300mm	CX-24		
Diffuse reflective	Long sensing range	800mm	CX-22-PN	Infrared LED	
	Short sensing range	300mm	CX-24-PN		

**NOTE: Mounting bracket is not supplied with the sensor. Please select from the range of optional sensor mounting brackets (five types).**

Note 1: The sensing range of the retroreflective type sensor is specified for the RF-230 reflector.  
Further, the sensing range is the possible setting range for the reflector. The sensor can detect an object less than 0.1m away (CX-28IR□: 50mm).

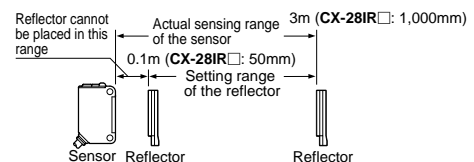

FX-D1/A1/M1

FX-13

FX-11A

FZ-10

CX-20

CX-30

Amplifier Built-in Type  
CX-RV/M5/D100/ND300R

EX-10

EX-20

## ORDER GUIDE

## Red LED type for transparent object sensing

The red LED type for transparent object sensing, which features easy beam alignment, is available.  
Model No.: **CX-28**, **CX-28-PN** (Sensing range: 50 to 500mm)

## Plug-in connector type (Not available for the self-diagnosis output type)

Plug-in connector type is available. When ordering this type, add '-J' to the model No.  
(e.g.) Plug-in connector type of **CX-21-PN** is '**CX-21-PN-J**'.  
Plug-in connector type of **CX-29-Y** is '**CX-29-J-Y**'.

## • Mating cable (2 Nos. are required for the thru-beam type.)

Type	Model No.	Length	Description
Straight	<b>CN-24E-C2</b>	Length: 2m	0.2mm <sup>2</sup> 4-core cabtyre cable with connector on one end Cable outer diameter: φ3.7mm
	<b>CN-24E-C5</b>	Length: 5m	
Elbow	<b>CN-24EL-C2</b>	Length: 2m	
	<b>CN-24EL-C5</b>	Length: 5m	

## • CN-24E-C2, CN-24E-C5

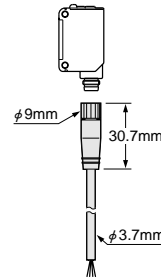

## • CN-24EL-C2, CN-24EL-C5

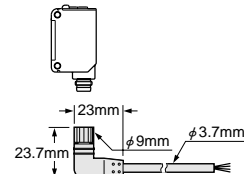
Self-diagnosis output type (Available with NPN output type only. However, not available for **CX-23□**, **CX-28□**, **CX-28IR□**, and plug-in connector type.)

The self-diagnosis output type is available. When ordering this type, add 'S' to the model No.  
(e.g.) Self-diagnosis output type of **CX-21** is '**CX-21S**'.

## Package without reflector

**CX-29□**, **CX-28□** and **CX-28IR□** are available without the reflector **RF-230**. When ordering this type, add suffix '-Y' to the model No.  
(e.g.) Package without reflector of **CX-29** is '**CX-29-Y**'.

## OPTIONS

Designation	Model No.	Description
Round slit mask (For thru-beam type sensor only)	<b>OS-CX-05</b> (Slit size φ0.5mm)	Slit on one side • Sensing range: 400mm [ <b>CX-21□</b> ] 300mm [ <b>CX-23□</b> ] • Min. sensing object: φ12mm
		Slit on both sides • Sensing range: 20mm [ <b>CX-21□</b> , <b>CX-23□</b> ] • Min. sensing object: φ0.5mm
	<b>OS-CX-1</b> (Slit size φ1mm)	Slit on one side • Sensing range: 900mm [ <b>CX-21□</b> ] 600mm [ <b>CX-23□</b> ] • Min. sensing object: φ12mm
		Slit on both sides • Sensing range: 100mm [ <b>CX-21□</b> , <b>CX-23□</b> ] • Min. sensing object: φ1mm
	<b>OS-CX-2</b> (Slit size φ2mm)	Slit on one side • Sensing range: 2m [ <b>CX-21□</b> ] 1.5m [ <b>CX-23□</b> ] • Min. sensing object: φ12mm
		Slit on both sides • Sensing range: 400mm [ <b>CX-21□</b> , <b>CX-23□</b> ] • Min. sensing object: φ2mm
Rectangular slit mask (For thru-beam type sensor only)	<b>OS-CX-05 × 6</b> (Slit size 0.5 × 6mm)	Slit on one side • Sensing range: 2m [ <b>CX-21□</b> ] 1.2m [ <b>CX-23□</b> ] • Min. sensing object: φ12mm
		Slit on both sides • Sensing range: 400mm [ <b>CX-21□</b> , <b>CX-23□</b> ] • Min. sensing object: 0.5 × 6mm
	<b>OS-CX-1 × 6</b> (Slit size 1 × 6mm)	Slit on one side • Sensing range: 3m [ <b>CX-21□</b> ] 2m [ <b>CX-23□</b> ] • Min. sensing object: φ12mm
		Slit on both sides • Sensing range: 1m [ <b>CX-21□</b> , <b>CX-23□</b> ] • Min. sensing object: 1 × 6mm
	<b>OS-CX-2 × 6</b> (Slit size 2 × 6mm)	Slit on one side • Sensing range: 5m [ <b>CX-21□</b> ] 3m [ <b>CX-23□</b> ] • Min. sensing object: φ12mm
		Slit on both sides • Sensing range: 2m [ <b>CX-21□</b> , <b>CX-23□</b> ] • Min. sensing object: 2 × 6mm

## Round slit mask

Fitted on the front face of the sensor with one-touch.

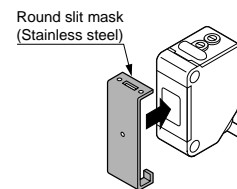

## Rectangular slit mask

Fitted on the front face of the sensor with one-touch.

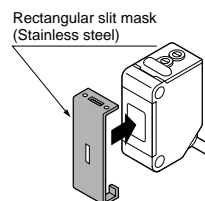

## OPTIONS

Designation	Model No.	Description
Reflector (For retro-reflective type sensor only)	<b>RF-210</b>	<ul style="list-style-type: none"> <li>Sensing range: 0.1 to 1m [CX-29□]</li> <li>50 to 250mm [CX-28IR□]</li> <li>Min. sensing object: <math>\phi</math>30mm</li> </ul>
	<b>RF-220</b>	<ul style="list-style-type: none"> <li>Sensing range: 0.1 to 1.5m [CX-29□]</li> <li>50 to 500mm [CX-28IR□]</li> <li>Min. sensing object: <math>\phi</math>35mm</li> </ul>
Reflector mounting bracket	<b>MS-RF21-1</b>	Protective mounting bracket for RF-210 It protects the reflector from damage and maintains alignment.
	<b>MS-RF22</b>	For RF-220
	<b>MS-RF23</b>	For RF-230
Reflective tape (For CX-29□ only)	<b>RF-11 (Note 1)</b>	<ul style="list-style-type: none"> <li>Ambient temperature: <math>-25</math> to <math>+50^{\circ}\text{C}</math></li> <li>Ambient humidity: 35 to 85% RH</li> <li>Notes: i) Keep the tape free from stress. If it is pressed too much, its capability may deteriorate.</li> <li>ii) Do not cut the tape. It will deteriorate the sensing performance.</li> </ul>
	<b>RF-12</b>	<ul style="list-style-type: none"> <li>Sensing range: 0.1 to 0.5m [CX-29□]</li> <li>Sensing range: 0.1 to 0.7m [CX-29□]</li> <li>0.15 to 0.4m [CX-28IR□]</li> </ul>
Sensor mounting bracket (Note 2)	<b>MS-CX2-1</b>	Foot angled mounting bracket It can also be used for mounting RF-210. (The thru-beam type sensor needs two brackets.)
	<b>MS-CX2-2</b>	Foot biangled mounting bracket Flat mounting saves height. It can also be used for mounting RF-210. (The thru-beam type sensor needs two brackets.)
	<b>MS-CX2-4</b>	Protective mounting bracket It protects the sensor from damage and maintains alignment. (The thru-beam type sensor needs two brackets.)
	<b>MS-CX2-5</b>	Back biangled mounting bracket Suitable for sensing from bottom of conveyors, etc. (The thru-beam type sensor needs two brackets.)
	<b>MS-CX-3</b>	Back angled mounting bracket (The thru-beam type sensor needs two brackets.)
Universal sensor mounting stand (Note 3)	<b>MS-AJ</b>	Basic assembly
	<b>MS-AJ-A</b>	Lateral arm assembly
	<b>MS-AJ-M</b>	Assembly for reflector
Sensor checker (Note 4)	<b>CHX-SC2</b>	It is useful for beam alignment of thru-beam type sensors. The optimum receiver position is given by indicators, as well as, an audio signal.

- Notes: 1) RF-11 cannot be used with CX-28IR□.  
 2) The plug-in connector type sensor does not allow use of some sensor mounting brackets because of the protrusion of the connector.  
 3) Refer to P.310~ for details of the universal sensor mounting stand.  
 4) Refer to P.378~ for details of the sensor checker CHX-SC2.

### Sensor mounting bracket

#### • MS-CX2-1

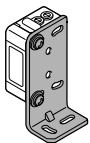

Two M3 (length 12mm) screws with washers are attached.

#### • MS-CX2-2

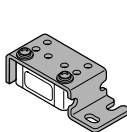

Two M3 (length 12mm) screws with washers are attached.

#### • MS-CX2-4

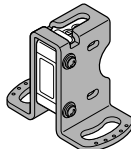

Two M3 (length 14mm) screws with washers are attached.

#### • MS-CX2-5

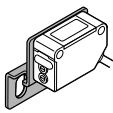

Two M3 (length 12mm) screws with washers are attached.

#### • MS-CX-3

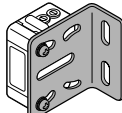

Two M3 (length 12mm) screws with washers are attached.

### Reflector

#### • RF-210

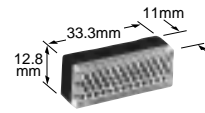

#### • RF-220

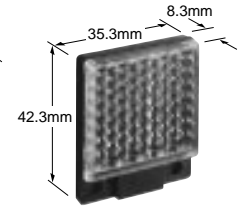

### Reflective tape

#### • RF-11



#### • RF-12

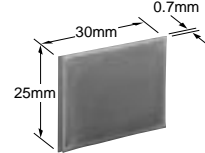

### Reflector mounting bracket

#### • MS-RF23

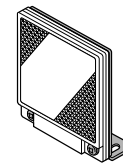

Two M4 (length 10mm) screws with washers are attached.

#### • MS-RF22

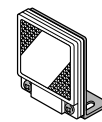

Two M3 (length 8mm) screws with washers are attached.

#### • MS-RF21-1

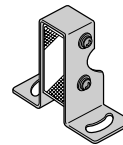

Two M3 (length 12mm) screws with washers are attached.

### Universal sensor mounting stand

#### • MS-AJ

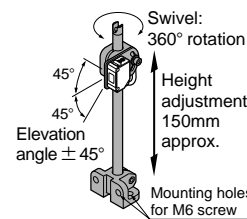

#### • MS-AJ-A

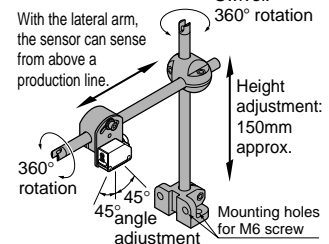

#### • MS-AJ-M

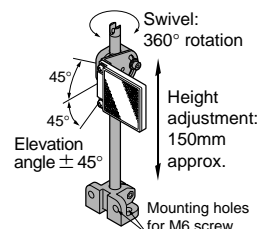

### Sensor checker

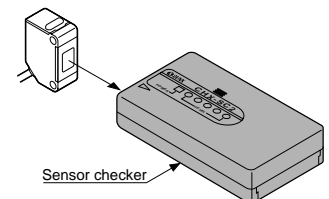

## SPECIFICATIONS

Item	Model No.	Type	Thru-beam		Retroreflective		Diffuse reflective	
			Narrow beam		With polarizing filters	For transparent object sensing	Long sensing range	Short sensing range
			NPN output type	CX-21	CX-23	CX-29	CX-28IR	CX-22
		PNP output type	CX-21-PN	CX-23-PN	CX-29-PN	CX-28IR-PN	CX-22-PN	CX-24-PN
Sensing range			10m	5m	0.1 to 3m (Note 1)	50 to 1,000mm (Note 1)	800mm (Note 2)	300mm (Note 2)
Sensing object			φ 12mm or more opaque object (Note 3)		φ 50mm or more opaque, translucent or specular object (Note 1)	φ 50mm or more opaque, translucent or transparent object (Note 1)	Opaque, translucent or transparent object	
Hysteresis							15% or less of operation distance	
Repeatability (perpendicular to sensing axis)			0.5mm or less	0.05mm or less	0.5mm or less		1mm or less	
Supply voltage			12 to 24V DC ± 10% Ripple P-P 10% or less					
Current consumption	NPN output type		Emitter: 35mA or less Receiver: 25mA or less		30mA or less		35mA or less	
	PNP output type		Emitter: 35mA or less Receiver: 30mA or less		35mA or less		40mA or less	
Sensing output			<NPN output type> NPN open-collector transistor • Maximum sink current: 100mA • Applied voltage: 30V DC or less (between sensing output and 0V) • Residual voltage: 1.5V or less (at 100mA sink current) 0.4V or less (at 16mA sink current)			<PNP output type> PNP open-collector transistor • Maximum source current: 100mA • Applied voltage: 30V DC or less (between sensing output and + V) • Residual voltage: 1.5V or less (at 100mA source current) 0.4V or less (at 16mA source current)		
Utilization category			DC-12 or DC-13					
Output operation			Switchable either Light-ON or Dark-ON					
Short-circuit protection			Incorporated					
Response time			1ms or less					
Operation indicator			Red LED (lights up when the sensing output is ON)					
Stability indicator			Green LED (lights up under stable light received condition or stable dark condition)					
Power indicator			Red LED (lights up when the power is ON)					
Sensitivity adjuster			Continuously variable adjuster					
Automatic interference prevention function					Incorporated (Two units of sensors can be mounted closely.)		Incorporated (Two units of sensors can be mounted closely.)	
Environmental resistance	Pollution degree		3 (Industrial environment)					
	Protection		IP67 (IEC)					
	Ambient temperature		- 25 to + 55°C (No dew condensation or icing allowed) (Note 4), Storage: - 30 to + 70°C					
	Ambient humidity		35 to 85% RH, Storage: 35 to 85% RH					
	Ambient illuminance		Sunlight: 10,000 lx at the light-receiving face, Incandescent light: 3,000 lx at the light-receiving face					
	EMC		Emission: EN50081-2, Immunity: EN50082-2					
	Voltage withstandability		1,000V AC for one min. between all supply terminals connected together and enclosure					
	Insulation resistance		20MΩ, or more, with 250V DC megger between all supply terminals connected together and enclosure					
	Vibration resistance		10 to 500Hz frequency, 1.5mm amplitude in X, Y and Z directions for two hours each					
Shock resistance		500m/s <sup>2</sup> acceleration (50G approx.) in X, Y and Z directions for three times each						
Emitting element			Infrared LED (modulated)	Red LED (modulated)	Infrared LED (modulated)			
Material			Enclosure: Polycarbonate, Lens: Polycarbonate, Indicator cover: Polycarbonate, Front cover: Polycarbonate (CX-29□: Acrylic)					
Cable			0.2mm <sup>2</sup> 3-core (thru-beam type emitter: 2-core) oil resistant cabtyre cable, 2m long					
Cable extension			Extension up to total 100m is possible with 0.3mm <sup>2</sup> , or more, cable (thru-beam type: both emitter and receiver).					
Weight			Emitter: 45g approx., Receiver: 50g approx.		50g approx.			
Accessories			Adjusting screwdriver: 1 No.		RF-230 (Reflector): 1 No. Adjusting screwdriver: 1 No.		Adjusting screwdriver: 1 No.	

Notes: 1) The sensing range and the sensing object of the retroreflective type sensor are specified for the RF-230 reflector.

Further, the sensing range is the possible setting range for the reflector.

The sensor can detect an object less than 0.1m away (CX-28IR□: 50mm).

2) The sensing range of the diffuse reflective type sensor is specified for white non-glossy paper (200 × 200mm) as the object.

3) If slit masks (optional) are fitted, an object of φ 0.5mm (using round slit mask) can be detected.

4) In case the sensor is to be used at an ambient temperature of - 15°C, or less, please contact our office.

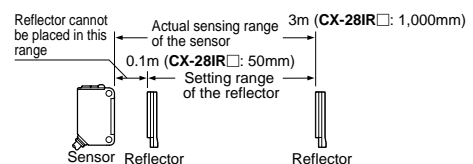

## I/O CIRCUIT AND WIRING DIAGRAMS

### NPN output type

#### I/O circuit diagram

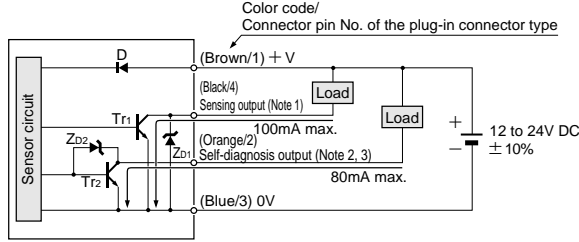

Internal circuit ← Users' circuit

- Notes: 1) The emitter of the thru-beam type sensor does not incorporate the sensing output.  
 2) Only CX-□S incorporates the self-diagnosis output.  
 3) The plug-in connector type sensor does not incorporate the self-diagnosis output. When connecting the mating cable, the white wire is not connected.

Symbols ... D: Reverse supply polarity protection diode  
 Zd1, Zd2: Surge absorption zener diode  
 Tr1, Tr2: NPN output transistor

#### Wiring diagram

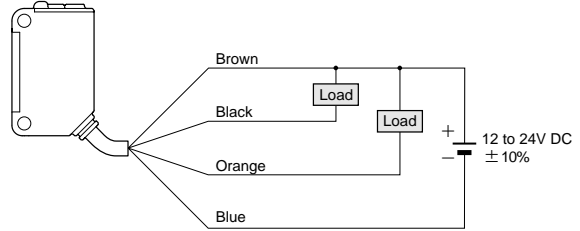

#### Connector pin position (Plug-in connector type)

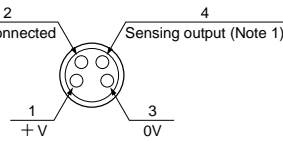

### PNP output type

#### I/O circuit diagram

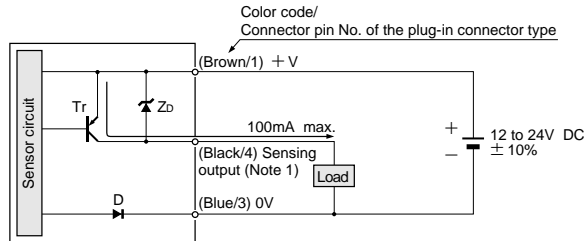

Internal circuit ← Users' circuit

- Notes: 1) The emitter of the thru-beam type sensor does not incorporate the sensing output.  
 2) When connecting the mating cable to the plug-in connector type sensor, the white wire is not connected.

Symbols ... D: Reverse supply polarity protection diode  
 Zd: Surge absorption zener diode  
 Tr: PNP output transistor

#### Wiring diagram

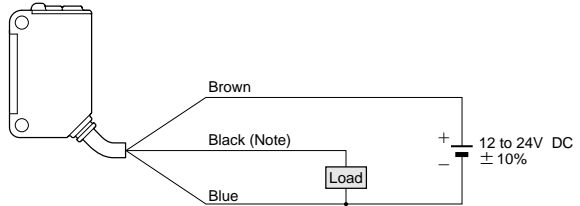

#### Connector pin position (Plug-in connector type)

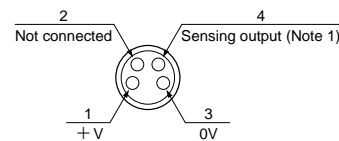

## SENSING CHARACTERISTICS (TYPICAL)

### All models

#### Correlation between setting distance and excess gain

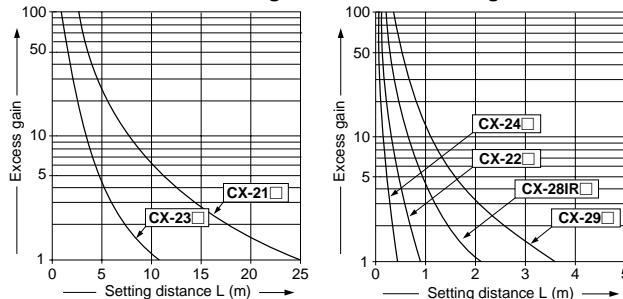



# CX-20

## SENSING CHARACTERISTICS (TYPICAL)

### CX-21 Thru-beam type

**Parallel deviation**

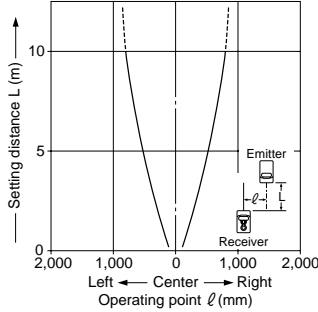

**Angular deviation**

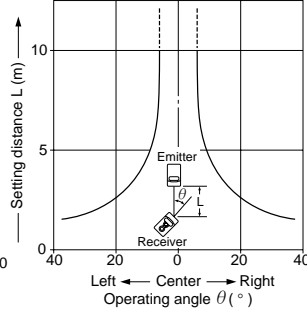

**Parallel deviation with round slit masks (phi 0.5mm)**

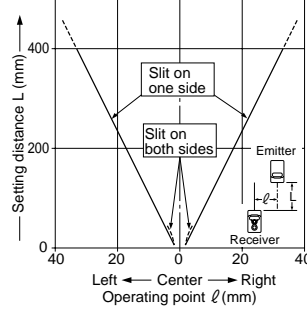

**Parallel deviation with round slit masks (phi 1mm)**

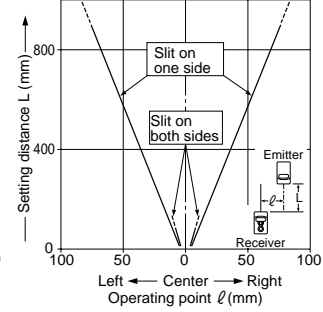

**Parallel deviation with round slit masks (phi 2mm)**

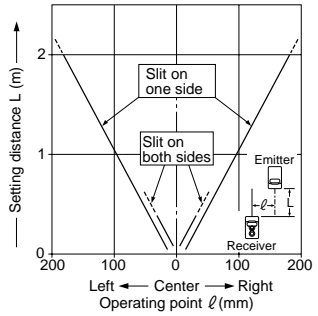

**Parallel deviation with rectangular slit masks (0.5 x 6mm)**

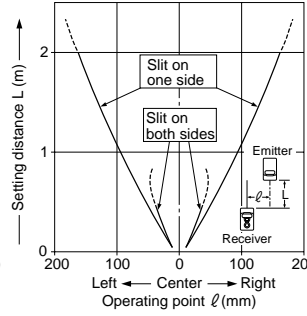

**Parallel deviation with rectangular slit masks (1 x 6mm)**

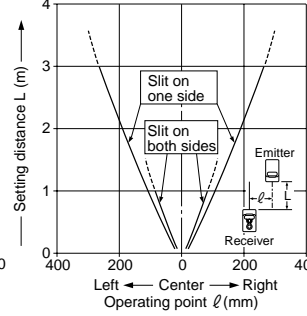

**Parallel deviation with rectangular slit masks (2 x 6mm)**

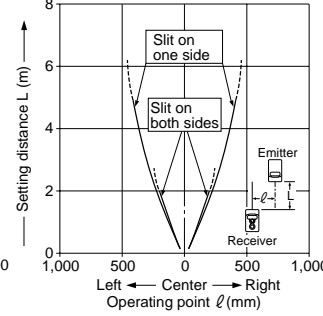

### CX-23 Thru-beam type

**Parallel deviation**

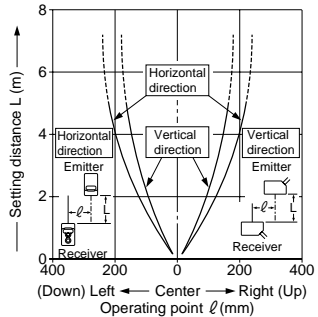

**Angular deviation**

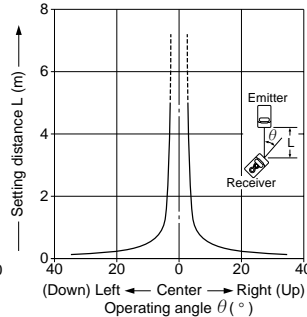

**Parallel deviation with round slit masks (phi 0.5mm)**

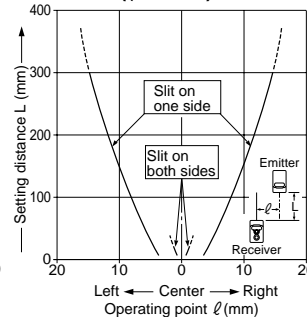

**Parallel deviation with round slit masks (phi 1mm)**

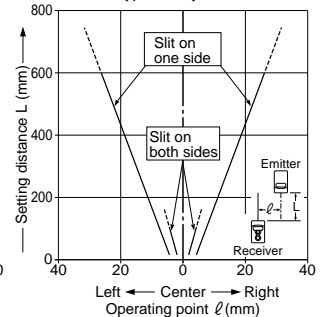

**Parallel deviation with round slit masks (phi 2mm)**

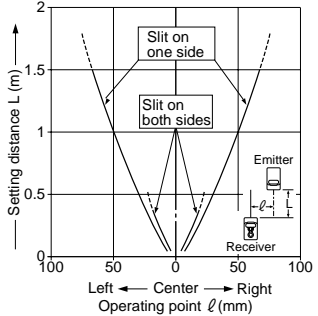

**Parallel deviation with rectangular slit masks (0.5 x 6mm)**

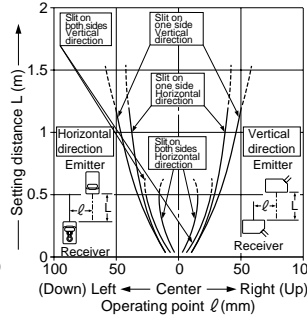

**Parallel deviation with rectangular slit masks (1 x 6mm)**

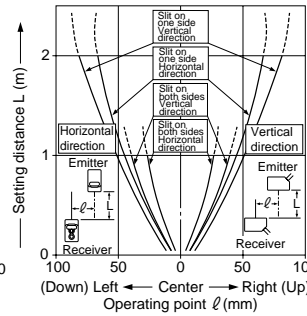

**Parallel deviation with rectangular slit masks (2 x 6mm)**

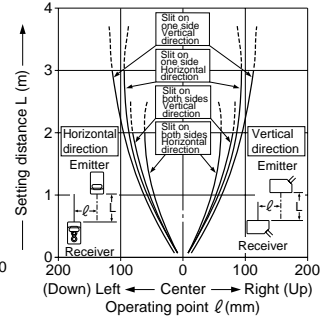

FX-D1/A1/M1

FX-13

FX-11A

FZ-10

CX-20

CX-30

CX-RVM5/D100/ND300R

EX-10

EX-20

Fiber Sensors

Amplifier Built-in Type

## SENSING CHARACTERISTICS (TYPICAL)

### CX-29 □ Retroreflective type

#### Parallel deviation

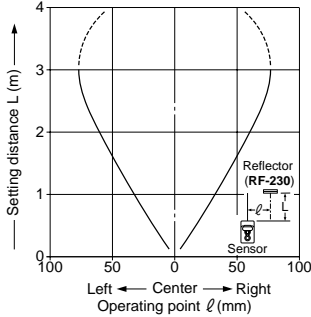

#### Angular deviation

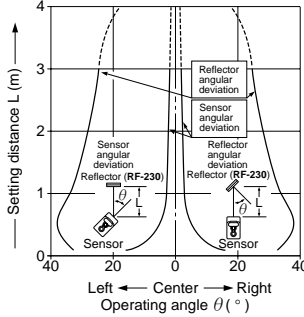

### CX-28IR □ Retroreflective type

#### Parallel deviation

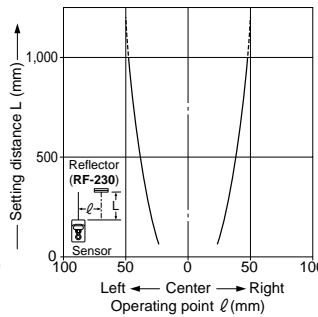

#### Angular deviation

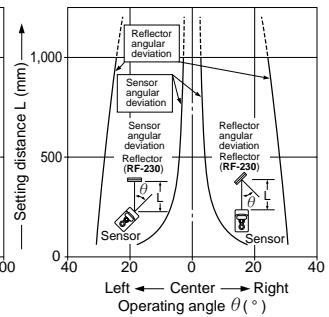

### CX-22 □ Diffuse reflective type

#### Sensing field

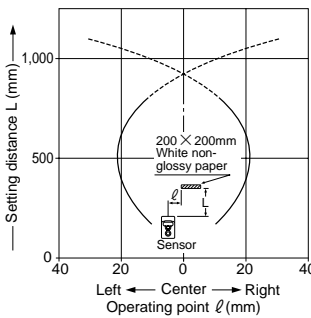

#### Correlation between sensing object size and sensing range

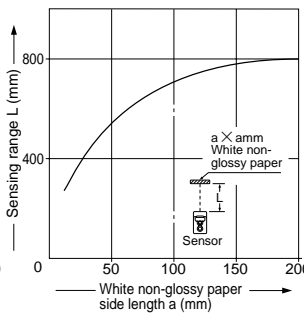

As the sensing object size becomes smaller than the standard size (white non-glossy paper 200 × 200mm), the sensing range shortens, as shown in the left graph.

( For plotting the left graph, the sensitivity has been set such that a 200 × 200mm white non-glossy paper is just detectable at a distance of 800mm. )

### CX-24 □ Diffuse reflective type

#### Sensing field

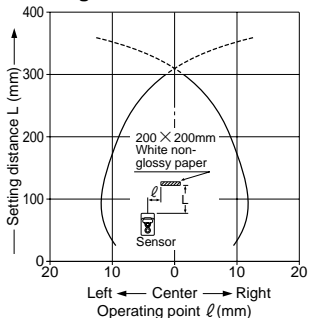

#### Correlation between sensing object size and sensing range

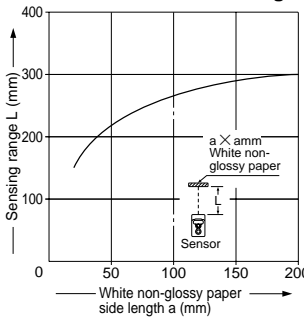

As the sensing object size becomes smaller than the standard size (white non-glossy paper 200 × 200mm), the sensing range shortens, as shown in the left graph.

( For plotting the left graph, the sensitivity has been set such that a 200 × 200mm white non-glossy paper is just detectable at a distance of 300mm. )

## PRECAUTIONS FOR PROPER USE

Refer to P.820~ for general precautions.

This product is not a safety sensor. Its use is not intended or designed to protect life and prevent body injury or property damage from dangerous parts of machinery. It is a normal object detection sensor.

### Mounting

- The tightening torque should be 0.5N·m or less.

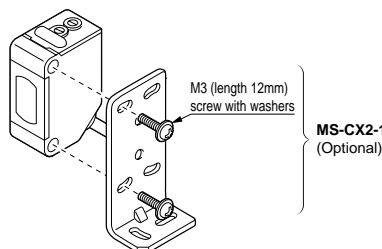

### Operation mode switch

	Light-ON mode is obtained when the switch is turned fully counterclockwise.
	Dark-ON mode is obtained when the switch is turned fully clockwise.

### Others

- Do not use during the initial transient time (50ms) after the power supply is switched on.
- When connecting the mating cable to the plug-in connector type sensor, the tightening torque should be 0.4N·m or less.

FX-D1/A1/M1

FX-13

Fiber Sensors  
FX-11A

FZ-10

CX-20

Amplifier Built-in Type  
CX-30

CX-RV/M5/D100/ND300R

EX-10

EX-20



# CX-20

## PRECAUTIONS FOR PROPER USE

Refer to P.820~ for general precautions.

### Retroreflective type sensor with polarizing filters

- If a shiny object is covered or wrapped with a transparent film, such as those described below, the retroreflective type sensor with polarizing filters may not be able to detect it.

In that case, follow the steps given below.

#### Example of sensing objects

- Can wrapped by clear film
- Aluminum sheet covered by plastic film
- Gold or silver color (glossy) label or wrapping paper

#### Steps

- Tilt the sensor with respect to the sensing object while fitting.
- Reduce the sensitivity.
- Increase the distance between the sensor and the sensing object.

### Self-diagnosis function (Self-diagnosis output type only)

- The sensor diagnoses the incident light intensity, and if it is reduced due to dirt or dust, or beam misalignment, an output is generated.

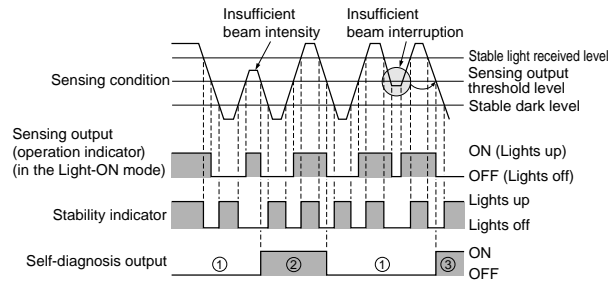

- ① The self-diagnosis output transistor stays in the 'OFF' state during stable sensing.
- ② When the sensing output changes, if the incident light intensity does not reach the stable light received level or the stable dark level, the self-diagnosis output becomes ON. Further, the self-diagnosis output changes state when the sensing output changes from Light to Dark state. (It is not affected by the operation mode switch.)
- ③ In case of insufficient beam interruption, there will be a time lag before the self-diagnosis output turns ON.

### Retroreflective type sensor for sensing transparent objects

- Optimum sensing is possible when the position of the transparent sensing object is set at the center of the sensor and the reflector.

If the sensing position is set near the sensor or the reflector, the sensing may be unstable. In this case, set the sensing position at the center of the sensor and the reflector.

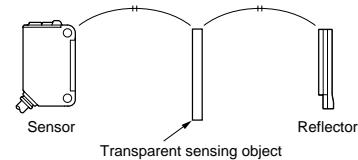

- When the sensor detects an uneven plastic receptacle or glass bin, the received light intensity may differ with the sensing position or direction. Adjust the sensitivity after confirming the stable sensing condition by turning the sensing object, etc.

- If the object is a transparent cylinder, feed it in a position as shown in Figure A. The sensor may fail to detect an object fed in a position as shown in Figure B.

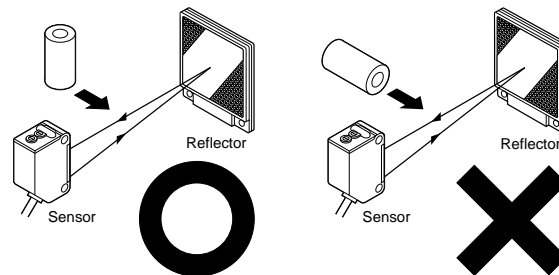
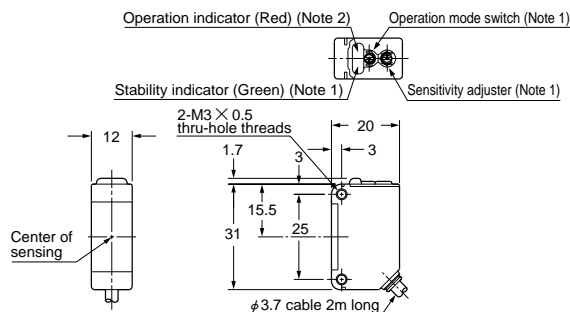

Fig. A

Fig. B

## DIMENSIONS (Unit: mm)

### CX-2□ Sensor



### CX-2□-J Sensor

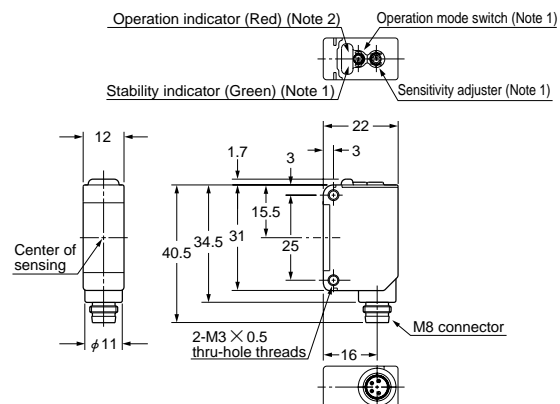

Notes: 1) Not incorporated on the emitter of the thru-beam type sensor.  
2) It is the power indicator (red) on the emitter of the thru-beam type sensor.

Notes: 1) Not incorporated on the emitter of the thru-beam type sensor.  
2) It is the power indicator (red) on the emitter of the thru-beam type sensor.

## DIMENSIONS (Unit: mm)

**RF-230** Reflector (Accessory for the retroreflective type sensor)

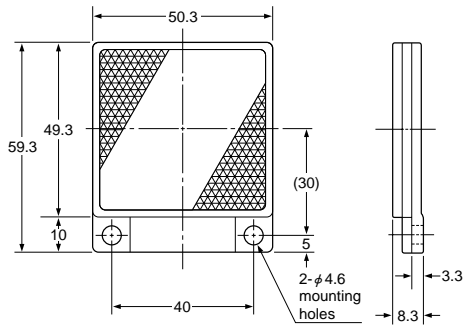

Material: Acrylic (Reflector)  
ABS (Base)

**RF-220** Reflector (Optional)

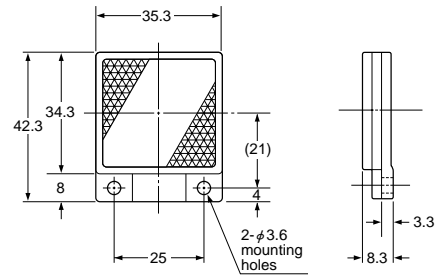

Material: Acrylic (Reflector)  
ABS (Base)

**RF-210** Reflector (Optional)

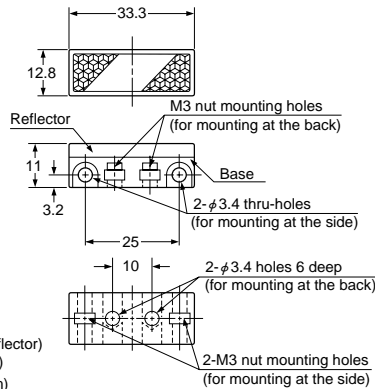

Material: Acrylic (Reflector)  
ABS (Base)  
Two M3 (length 8mm)  
screws with washers and  
two nuts are attached.

**RF-11** Reflective tape (Optional)

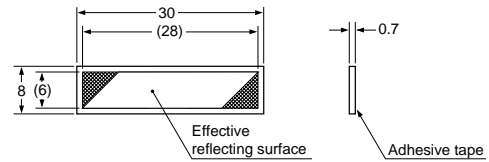

Material: Acrylic

**RF-12** Reflective tape (Optional)

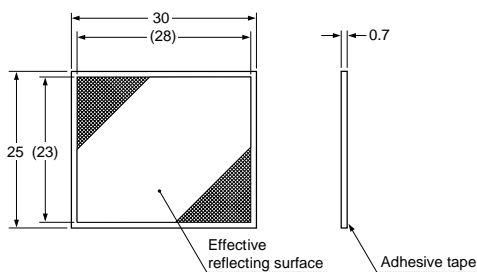

Material: Acrylic

FX-D1/A1/M1

FX-13

FX-11A

FZ-10

CX-20

CX-30

Amplifier Built-in Type  
CX-RV/M5/D100/ND300R

EX-10

EX-20

## DIMENSIONS (Unit: mm)

### MS-CX2-1 Sensor mounting bracket (Optional)

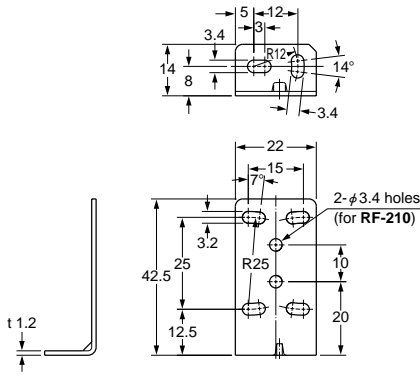

Material: Stainless steel (SUS304)  
Two M3 (length 12mm) screws with washers are attached.

### Assembly dimensions Mounting drawing with CX-2

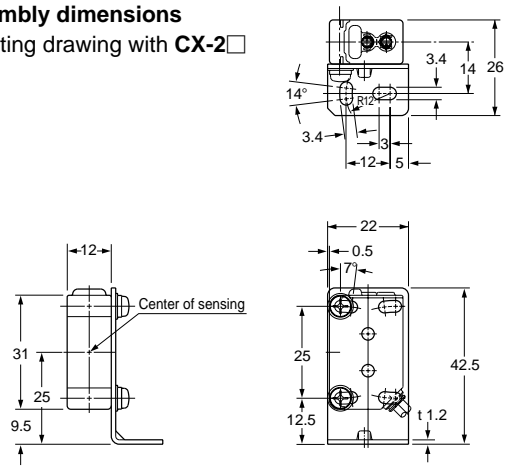

### MS-CX2-2 Sensor mounting bracket (Optional)

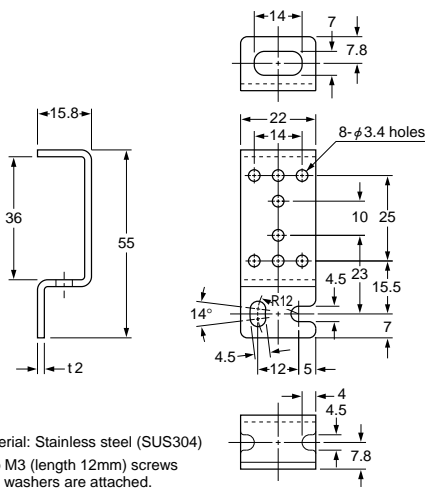

Material: Stainless steel (SUS304)  
Two M3 (length 12mm) screws with washers are attached.

### Assembly dimensions Mounting drawing with CX-2

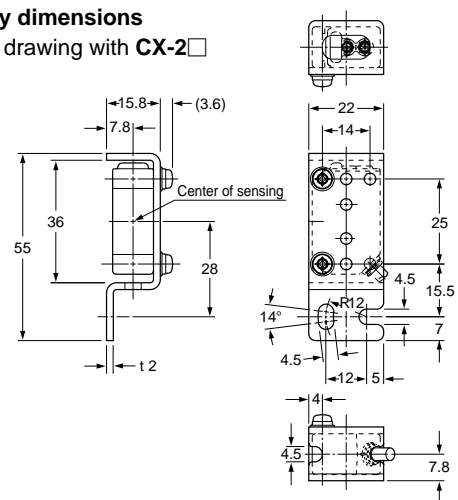

### MS-CX2-4 Sensor mounting bracket (Optional)

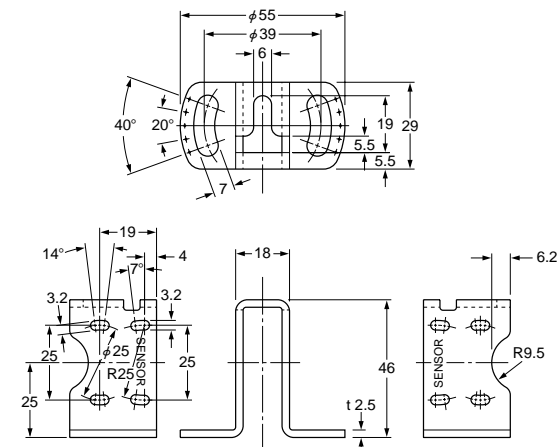

Material: Stainless steel (SUS304)  
Two M3 (length 14mm) screws with washers are attached.

### Assembly dimensions Mounting drawing with CX-2

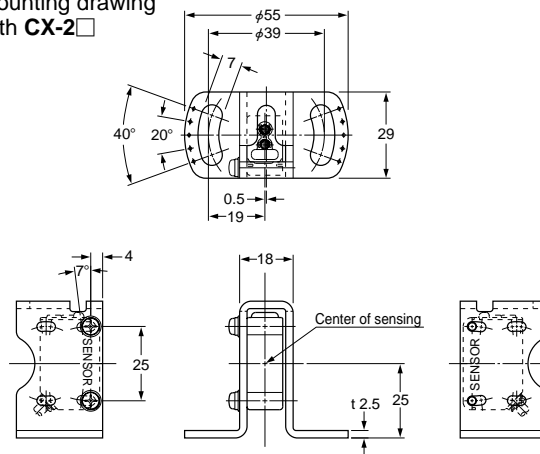

## DIMENSIONS (Unit: mm)

### MS-CX2-5 Sensor mounting bracket (Optional)

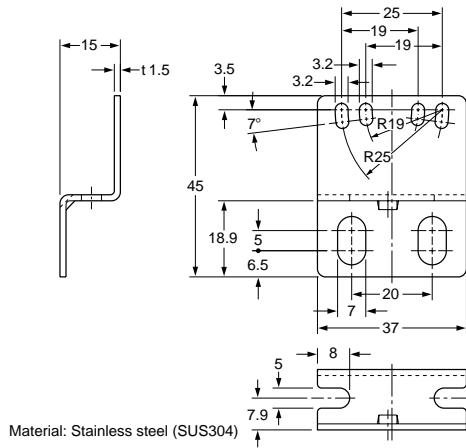

#### Assembly dimensions

Mounting drawing with CX-2□

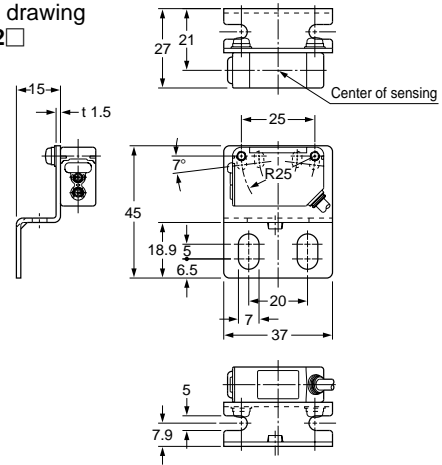

### MS-CX-3 Sensor mounting bracket (Optional)

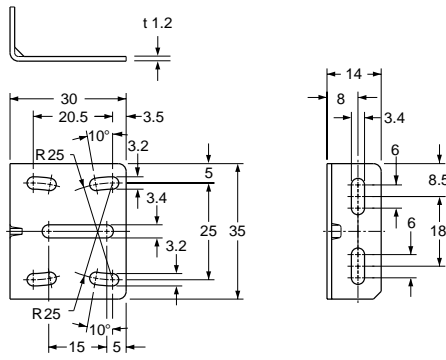

#### Assembly dimensions

Mounting drawing with CX-2□

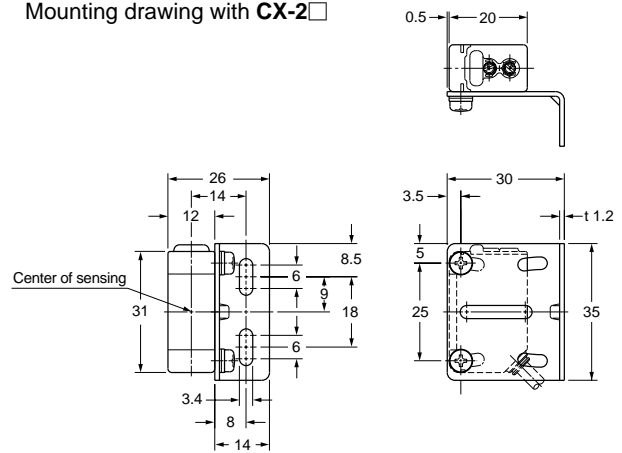

### MS-RF21-1 Reflector mounting bracket for RF-210 (Optional)

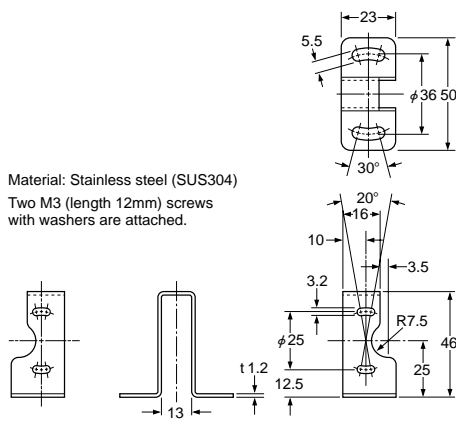

#### Assembly dimensions

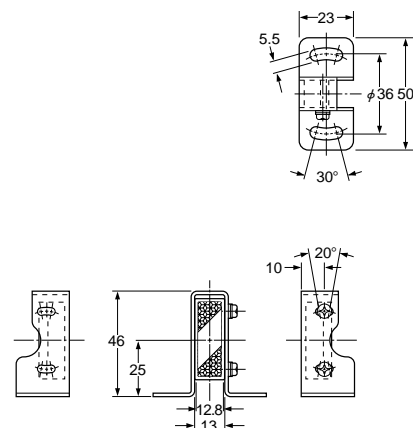

FX-D1/A1/M1

FX-13

FX-11A

FZ-10

CX-20

CX-30

Amplifier Built-in Type  
CX-RV/M5/D100/ND300R

EX-10

EX-20

## DIMENSIONS (Unit: mm)

FX-D1/A1/M1

FX-13

FX-11A

Fiber Sensors

FZ-10

CX-20

CX-30

CX-RVM5/D100/ND300R

Amplifier Built-in Type

EX-10

EX-20

### MS-RF22 Reflector mounting bracket for RF-220 (Optional)

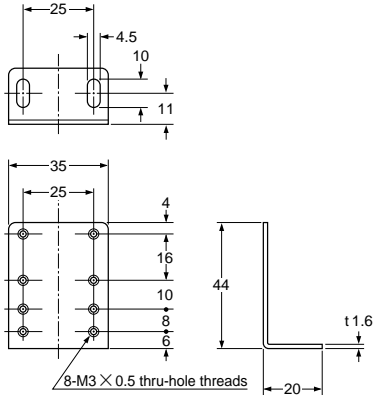

### Assembly dimensions

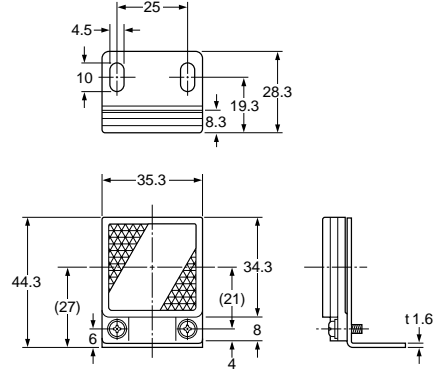

Material: Cold rolled carbon steel (SPCC)  
(Uni-chrome plated)

Two M3 (length 8mm) screws with washers are attached.

### MS-RF23 Reflector mounting bracket for RF-230 (Optional)

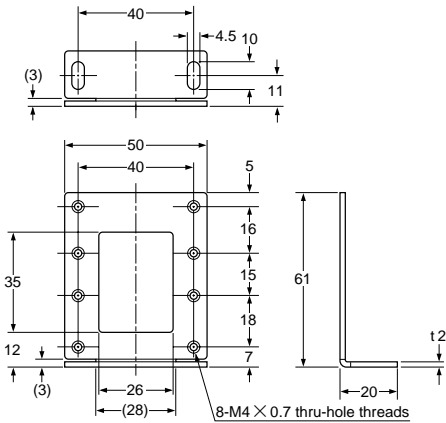

### Assembly dimensions

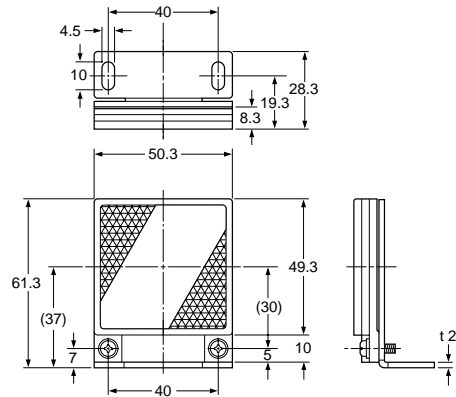

Material: Cold rolled carbon steel (SPCC)  
(Uni-chrome plated)

Two M4 (length 10mm) screws with washers are attached.

## DIMENSIONS (Unit: mm)

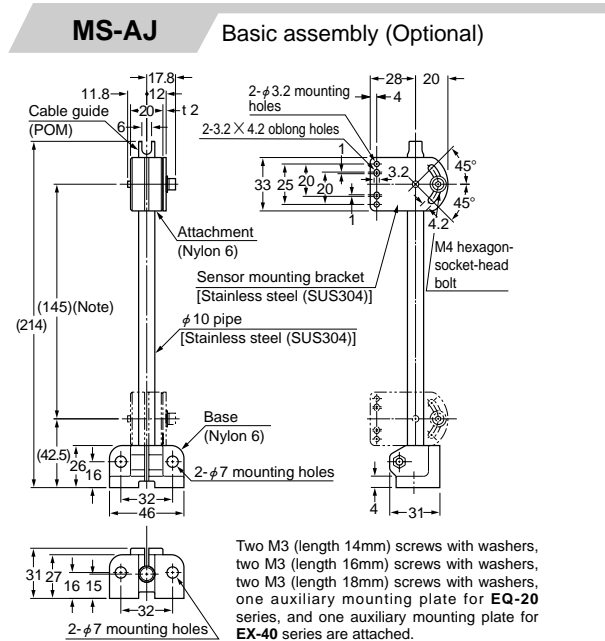

Note: The dimensions in the brackets indicate the adjustable range of the movable part.

### Assembly dimensions with CX-20 series (Mounting part only)

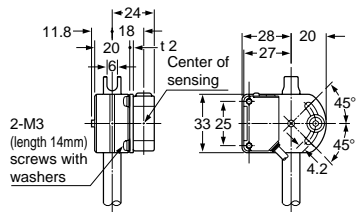

### Assembly dimensions with RF-210 (Reflector) (Mounting part only)

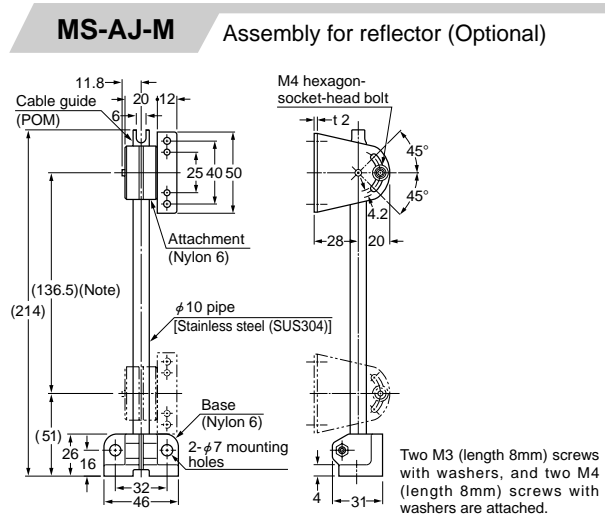
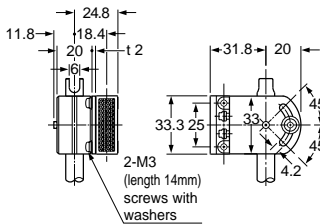

Note: The dimensions in the brackets indicate the adjustable range of the movable part.

### Assembly dimensions with RF-220 (Reflector) (Mounting part only)

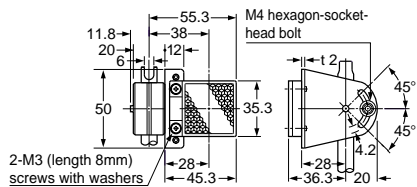

### Assembly dimensions with RF-230 (Reflector) (Mounting part only)

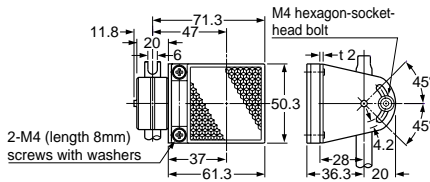

### MS-AJ-A Lateral arm assembly (Optional)

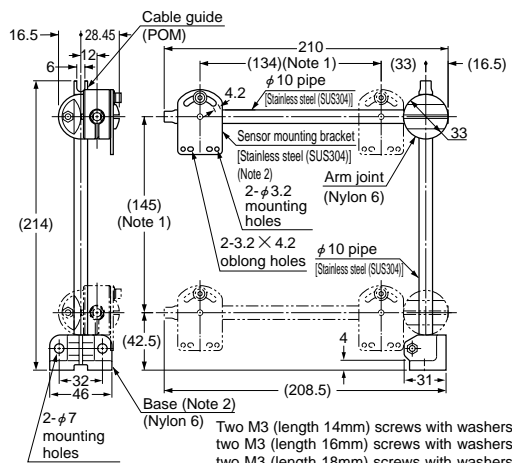

Notes: 1) The dimensions in the brackets indicate the adjustable range of the movable part.

2) Refer to MS-AJ (basic assembly) for the assembly diagram with the base, sensor mounting bracket, sensor or reflector.

FX-D1/A1/M1

Fiber Sensors

FX-13

FX-11A

FZ-10

CX-20

CX-30

Amplifier Built-in Type

CX-RV/M5/D100/ND300R

EX-10

EX-20