

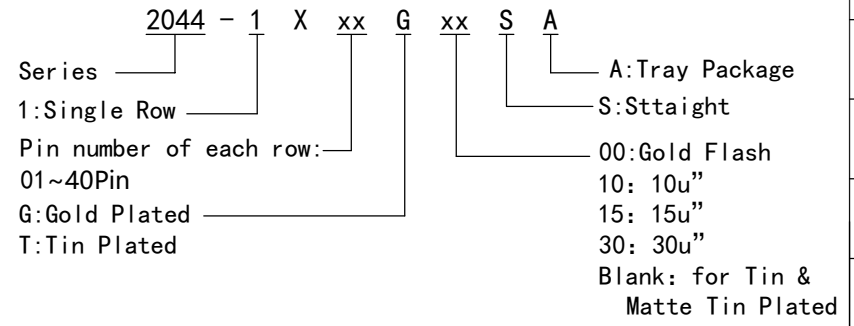

REV.	SPECIFICATION	ECN NO.	APPD.
R6		ECN220849	

**Material and plating**  
Housing: PBT, PA6T, UL94V-0, Black  
Contacts: Brass  
Gold plated or 80u"min Tin Plated on contact area and  
Gold Flash or 80u"min Tin Plated on press fit or solder tail  
over Nickel 50u"Min.  
**Electrical characteristics:**  
Current Rating: 2 AMP  
Dielectric Withstanding Voltage: Ac 1000V for 1 minute.  
Insulator Resistance: 1000MΩ min. at DC 500V  
Contact Resistance: 20mΩ max. at DC 100mA.  
Operating Temperature: -55° C~+105° C  
\*RoHS compliant  
Insertion Depth: 2.55mm to 6.20mm  
Ⓞ Important Dimensions

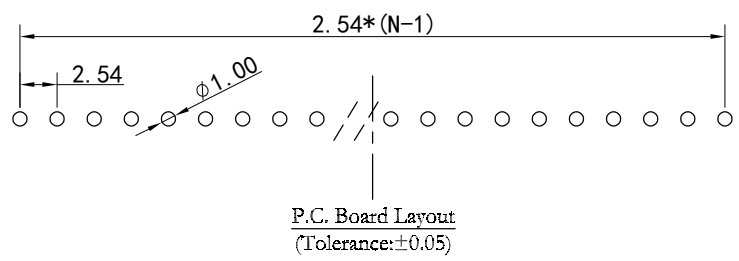
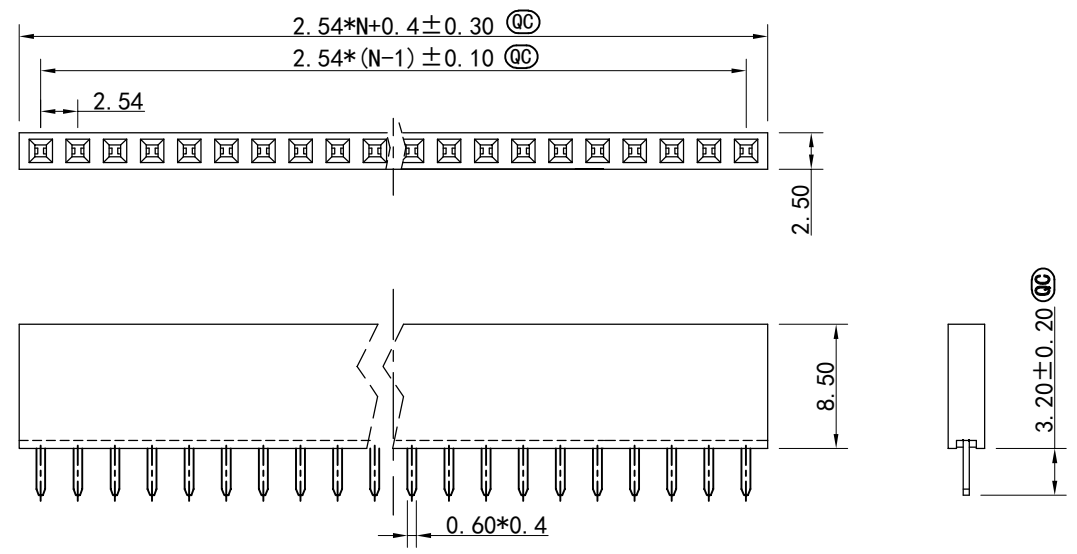

Tolerances	Dwg. No.	2044-D0000-003		Title:		 深圳市格林柏电子技术开发有限公司 <b>P/N: 2044-1XxxgxxSA</b>			
x = ±0.5	Projection	⊕ ⏏		2044系列 单排排母 间距					
.x = ±0.25	Unit	mm	Scale	1:1	2.54mm 1XNP 直插 H=8.5 PC3.2	SHEET	1/1	Ver. No.	R6
.xx = ±0.15	Drawn By	ZY 08/23'22		PBT Y型 镀金GF					