

707 - 3021 / 3033 / 3045 / 3057 / **SPRING PLUNGERS**
with round-ended pin and slot

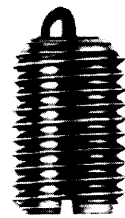
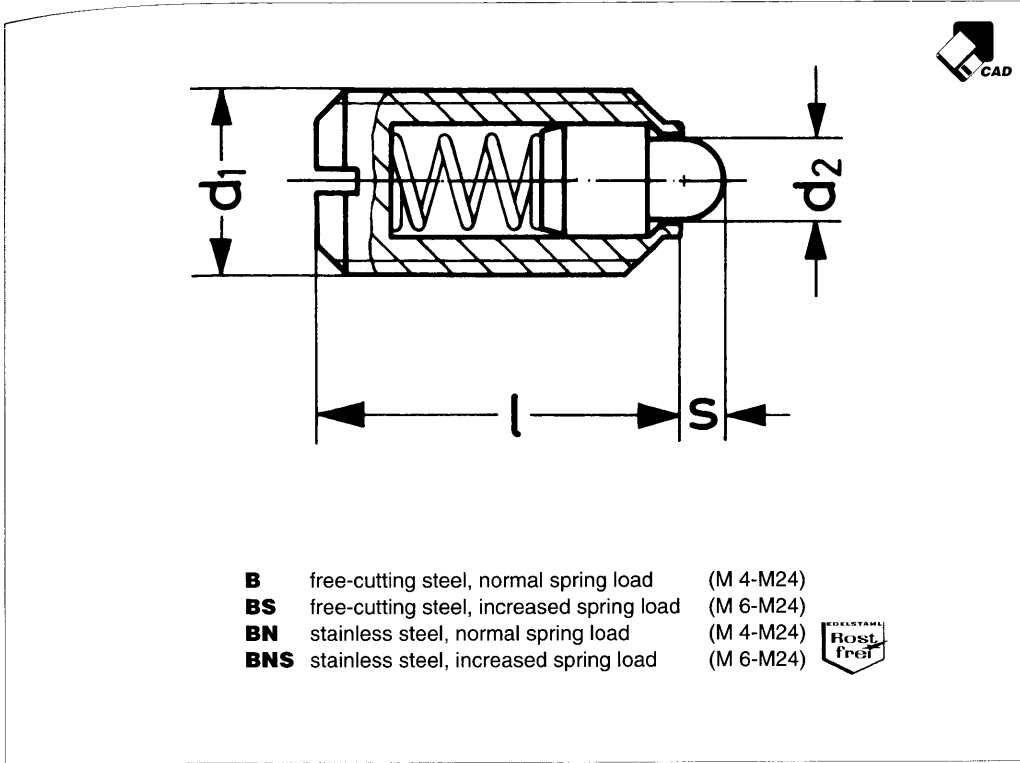

Material:

Model B and BS: Free cutting steel
Model BN and BNS: Stainless steel
(including round-ended pin & spring)

Finish:

Free-cutting steel qualities blacked, thrust pin hardened. Type BS ball coated yellow, Type BNS body tip marked yellow

Note:

These spring plungers may be used for location or for applying pressure or lifting off. The stainless steel qualities are heat-resistant up to 250°C

- B** free-cutting steel, normal spring load (M 4-M24)
- BS** free-cutting steel, increased spring load (M 6-M24)
- BN** stainless steel, normal spring load (M 4-M24)
- BNS** stainless steel, increased spring load (M 6-M24)



POSITION

| Order No. | | | | d ₁ | d ₂ | l | s | Type B and BN Pressure | | Type BS and BNS Pressure | | g |
|------------------|--------------|--------------|--------------|----------------|----------------|----|-----|------------------------|----------|--------------------------|----------|------|
| Type B | BS | BN | BNS | | | | | initial N≈ | final N≈ | initial N≈ | final N≈ | |
| 3215.W104 | - | .W504 | - | M 4 | 1,8 | 9 | 1,5 | 6 | 20 | - | - | 0,6 |
| .W105 | - | .W505 | - | M 5 | 2,4 | 12 | 2,0 | 6 | 20 | - | - | 0,9 |
| .W106 | .W306 | .W506 | .W706 | M 6 | 2,7 | 14 | | 7 | 20 | 13 | 34 | 1,5 |
| .W108 | .W308 | .W508 | .W708 | M 8 | 4,0 | 16 | 18 | 37 | 35 | 73 | 3,5 | |
| .W110 | .W310 | .W510 | .W710 | M10 | 4,5 | 19 | 2,5 | 21 | 45 | 35 | 83 | 7,0 |
| .W112 | .W312 | .W512 | .W712 | M12 | 6,0 | 22 | 3,5 | 23 | 65 | 58 | 110 | 10,0 |
| .W116 | .W316 | .W516 | .W716 | M16 | 8,5 | 24 | 4,5 | 44 | 95 | 58 | 155 | 24,0 |
| .W120 | .W320 | .W520 | .W720 | M20 | 10,0 | 30 | 6,5 | 49 | 130 | 78 | 200 | 43,0 |
| .W124 | .W324 | .W524 | .W724 | M24 | 12,0 | 34 | 8,0 | 70 | 158 | 98 | 240 | 70,0 |

