

A1	GND	B12	GND
A2	SSTXP1	B11	SSRXP1
A3	SSTXN1	B10	SSRXN1
A4	VBUS	B9	VBUS
A5	CC1	B8	SBU2
A6	DP1	B7	DN2
A7	DN1	B6	DP2
A8	SBU1	B5	CC2
A9	VBUS	B4	VBUS
A10	SSRXN2	B3	SSTXN2
A11	SSRXP2	B2	SSTXP2
A12	GND	B1	GND
PIN	SIGNAL NAME	PIN	SIGNAL NAME

Model No.	Contact plating	Color
MUP-U20205-01	Au: 3u"	Black
MUP-U20205-04	Au: 15u"	Black
MUP-U20205-05	Au: 3u"	Blue

ITEM	PART NAME	Q'TY	MATERIAL	FINISH
1	Molding	1	THERMOPLASTIC	Black or Blue, UL94V-0
2	CONTACT	24	HIGH CONDUCTIVITY COPPER	Contact area: Au 3u" or 15u"
3	MID-PLATE	1	STAINLESS STEEL	Cleaning
4	TOP SHELL	1	STAINLESS STEEL	Ni plated over all
5	OUTER SHELL	1	STAINLESS STEEL	Ni plated over all

NOTE:

- MECHANICAL:
 - MATING FORCE: 0.5~2.0Kg
 - UMMATING FORCE: Initial: 0.8~2.0Kg
After 500 to 10,000cycles: 0.6~2.0Kg
 - FREQUENCY: 500±50 CYCLES/HOUR, 10000 CYCLES;
- ELECTRICAL CHARACTERISTICS:
 - CURRENT RATING: 1.25A/PIN FOR FOR VBUS AND GND
0.25 A FOR OTHER PINS
 - INITIAL CONTACT RESISTANCE: 40mΩ Max.
 - INSULATION RESISTANCE: 100MΩ MIN
 - WITHSTANDING VOLTAGE: 100V AC, 1 MINUTE;
- ENVIRONMENTAL
TEMPERATURE RANGE: -40°C TO +85°C.

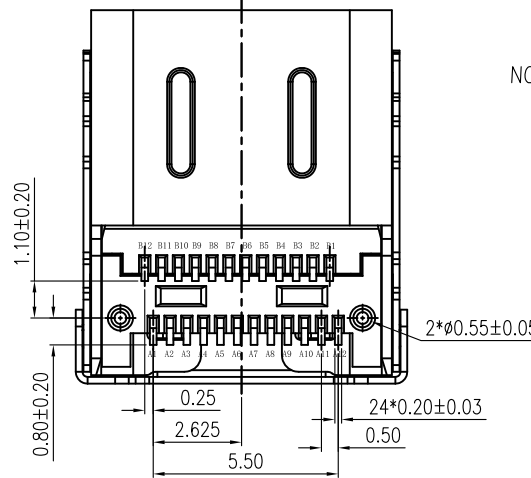

Unless otherwise specified, other tolerance are:

MUP MUP INDUSTRIAL CO.,LTD.

NAME: **USB Type C Dual-Row SMT Receptacle**

MODEL NO: **MUP-U20205-XX**

TYPE : **24P & USB 3.1 Board center height 3.40**

PROJ.	UNIT	SCALE	DRAW	Roy	2020/02/15	DWG NO.:
①	mm	1:1	CHECKED	lucky	2020/02/15	DWG-U20205-XX-01
CUSTOMER DRAWING			APPROVAL	lucky	2020/02/15	SHEET
					1/2	REVISION
						4

REV.	DESCRIPTION OF REVISIONS	APPR.	CHKD.	DRAW.	DATE
△1	Original reversion	lucky	lucky	Roy	2020/02/15
△2	Add RECEPTACLE&PLUG MATED CONTITION	lucky	lucky	Roy	2021/05/13
△3	Add PART NO.	lucky	lucky	Roy	2022/03/04
△4	Change product model No.	lucky	lucky	Roy	2023/10/25

REV.	DESCRIPTION OF REVISIONS	APPR.	CHKD.	DRAW.	DATE
△	Original reversion	lucky	lucky	Roy	2020/02/15
△	Add RECEPTACLE&PLUG MATED CONTITION	lucky	lucky	Roy	2021/05/13
△	Add PART NO.	lucky	lucky	Roy	2022/03/04
△	Change product model No.	lucky	lucky	Roy	2023/10/25

NOTES

1. NUMBER OF CONNECTORS:600PCS/REEL
2. LEAD TAPE LENGTH

EMPTY 12PCS	PART 600PCS	EMPTY 12PCS
LEADER 196mm	COMPONENT SUPPLIER	TRAILER 196mm

3. QUANTITY:6000/CARTON

4. WEIGHT :

4.1 NET WEIGHT : 6.52 Kg

4.2 GROSS WEIGHT : 10.7 Kg

5.Meas:350Lx350Wx315H mm

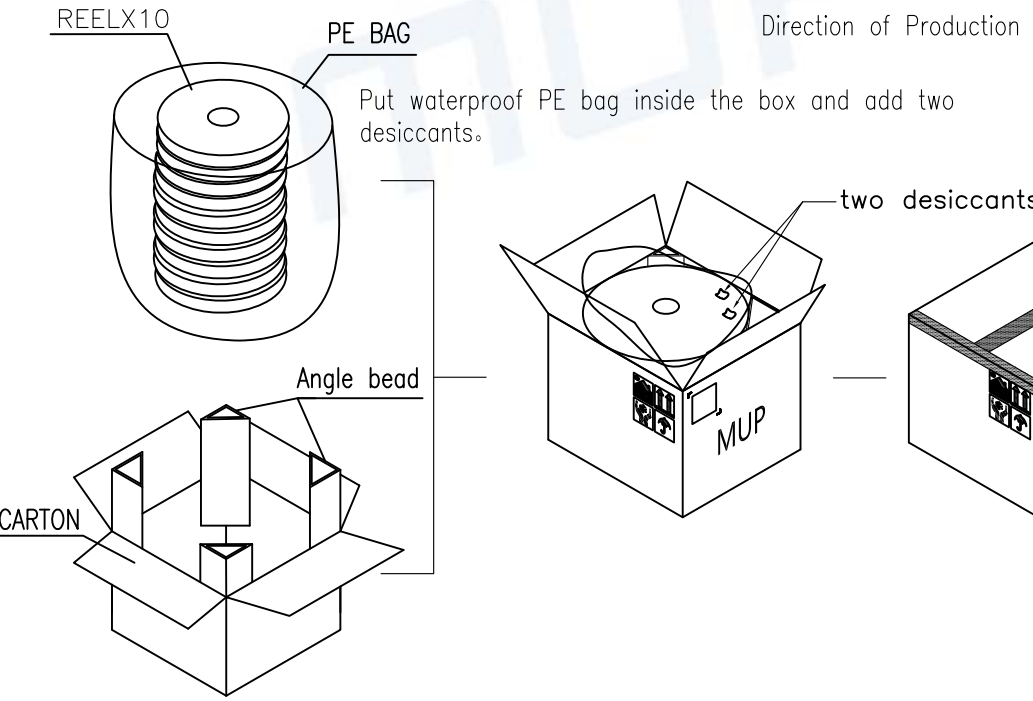
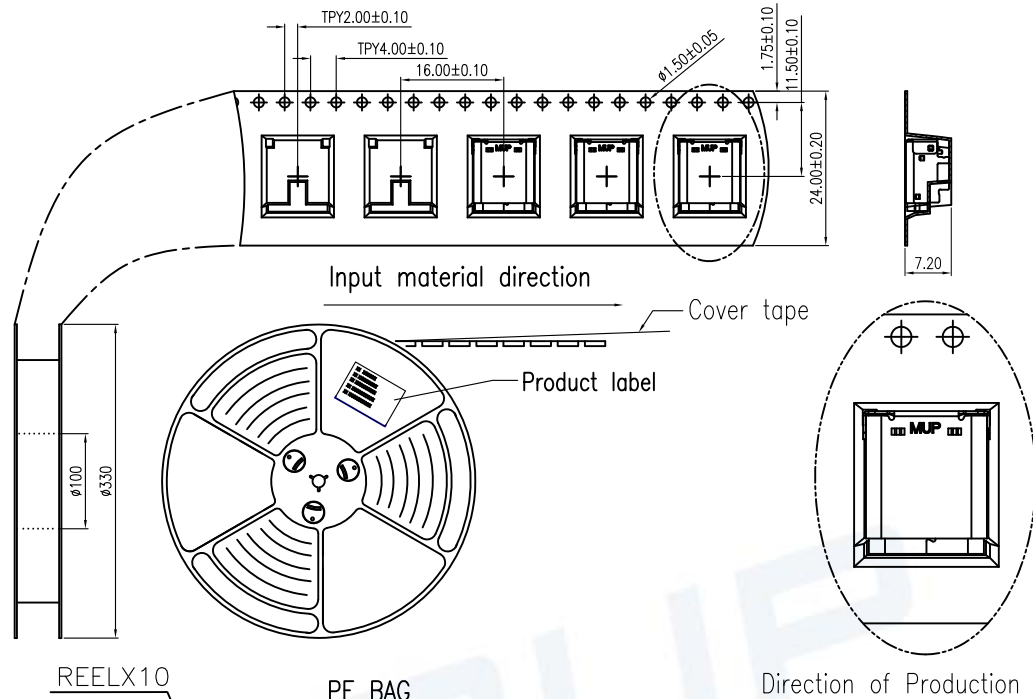

Unless otherwise specified, other tolerance are:		MUP MUP INDUSTRIAL CO.,LTD.			
X ±0.40	X' ±5'	NAME: USB Type C Dual-Row SMT Receptacle			
X.X ±0.30	X.X' ±4'	MODEL NO: MUP-U20205-XX			
X.XX ±0.20	X.XX' ±3'	TYPE : 24P & USB 3.1 Board center height 3.40			
X.XXX ±0.10	X.XXX' ±2'	PROJ.	UNIT	SCALE	DRAW
		mm	1:1	Roy	2020/02/15
CUSTOMER DRAWING		APPROVAL		lucky	2020/02/15
		DWG NO.:		DWG-U20205-XX-01	
		SHEET		2/2	
		REVISION		4	

