

Sensor/actuator box - SACB- 8/3-C QO-0,34 - 1548370

Please be informed that the data shown in this PDF Document is generated from our Online Catalog. Please find the complete data in the user's documentation. Our General Terms of Use for Downloads are valid (<http://phoenixcontact.com/download>)



Sensor/actuator box, Application: Standard, Connection method: QUICKON, 0.14 mm² ... 0.34 mm², Number of slots: 8, Number of positions: 3, Slot assignment: single, Status indication: No, Universal; Master cable connection: Pluggable screw connection 180°, Shielding: No

Product Features

- Safety in the field, thanks to molded housing and high degree of protection
- Flexible, distributed bundling of signals in one master cable
- Innovative and time-saving assembly with insulation displacement connection
- Flexible: distributor box with connector hood for on-site assembly



Key Commercial Data

Packing unit	1 pc
Weight per Piece (excluding packing)	368.1 g
Custom tariff number	85366990
Country of origin	Poland

Technical data

General

Rated voltage	48 V
	60 V DC
Current carrying capacity per I/O signal	2 A
Current carrying capacity per slot	4 A
Total rated current	10 A
	2x 8 A (For electrical isolation)
Number of positions	3
Number of slots	8
Flammability rating according to UL 94	V0
Sensor/actuator connection system	QUICKON

Sensor/actuator box - SACB- 8/3-C QO-0,34 - 1548370

Technical data

Ambient conditions

Degree of protection	IP65
	IP67
	IP69K
Ambient temperature (operation)	-30 °C ... 80 °C

Master cable data/connection data

Connection method	Pluggable screw connection
Conductor cross section min. (signal)	0.14 mm ²
Conductor cross section max. (signal)	1.5 mm ²
Conductor cross section AWG min. (signal)	26
Conductor cross section AWG max. (signal)	16
Stripping length (signal)	7 mm
Conductor cross section min. (energy)	0.14 mm ²
Conductor cross section max. (energy)	1.5 mm ²
Conductor cross section AWG min. (energy)	26
Conductor cross section AWG max. (energy)	16
External cable diameter min.	7 mm
External cable diameter max.	12 mm
Stripping length	50 mm (Master cable)
Tightening torque, cover screw	0.35 Nm
Tightening torque, union nut	2.5 Nm
Tightening torque of mounting screw for fixing the housing	0.5 Nm

Conductor data

Structure of individual litz in acc. with VDE 0295 / smallest wire diameter	Class 2-6
Wire insulation material	PVC/PE/PP
Wire diameter including insulation	0.7 mm ... 1.3 mm
Minimum external conductor diameter	3.5 mm
Maximum external conductor diameter	6 mm
Tightening torque, union nut	2 Nm
Wrench size, union nut	13 mm
Conductor cross section flexible min.	0.14 mm ²
Conductor cross section flexible max.	0.34 mm ²
Conductor cross section AWG min.	26
Conductor cross section AWG max.	22

Insulation material

Housing material	PBT
Material of the moulding mass	PUR

Sensor/actuator box - SACB- 8/3-C QO-0,34 - 1548370

Technical data

Insulation material

Contact material	Steel/copper
Contact surface material	Sn
Material of contact, master cable side	CU alloy
Material of contact surface, master cable side	Gold-plated
Material of the contact carrier on the master cable side	PA 66 V0

Pin assignment

Slot/position = Wire color or connection	1 / 4 (A) = 1 / 4
	2 / 4 (A) = 2 / 4
	3 / 4 (A) = 3 / 4
	4 / 4 (A) = 4 / 4
	5 / 4 (A) = 5 / 4
	6 / 4 (A) = 6 / 4
	7 / 4 (A) = 7 / 4
	8 / 4 (A) = 8 / 4
	1-8 / 1 (+ 48 V) = U _N
	1-8 / 3 (0 V) = 0 V

Standards and Regulations

Connection in acc. with standard	CUL
Flammability rating according to UL 94	V0

Classifications

eCl@ss

eCl@ss 4.0	27250313
eCl@ss 4.1	27250313
eCl@ss 5.0	27143423
eCl@ss 5.1	27143423
eCl@ss 6.0	27143423
eCl@ss 7.0	27449001
eCl@ss 8.0	27279219

ETIM

ETIM 3.0	EC001856
ETIM 4.0	EC002585
ETIM 5.0	EC002585

Sensor/actuator box - SACB- 8/3-C QO-0,34 - 1548370

Classifications

UNSPSC

UNSPSC 6.01	31261501
UNSPSC 7.0901	31261501
UNSPSC 11	31261501
UNSPSC 12.01	31261501
UNSPSC 13.2	31261501

Approvals

Approvals

Approvals

UL Recognized / cUL Recognized / EAC / cULus Recognized

Ex Approvals

Approvals submitted

Approval details

UL Recognized 	
Nominal voltage UN	48 V

cUL Recognized 	
Nominal voltage UN	48 V

EAC

Sensor/actuator box - SACB- 8/3-C QO-0,34 - 1548370

Approvals



Drawings

Schematic diagram

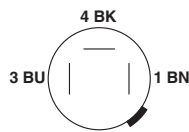

QUICKON connection, 3-pos.

Schematic diagram

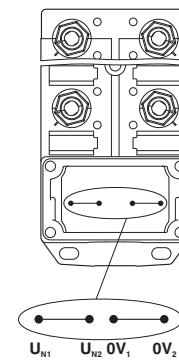

Potential U_{N1} and U_{N2} bridged. Potential assignment: $U_{N1} = U_{N2}$ = slots 1,2,3,4,5,6,7,8.

Schematic diagram

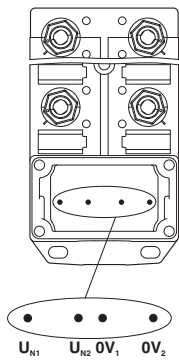

Electrically isolated. Potential assignment: U_{N1} = slots 1,3,5,7 and U_{N2} = slots 2,4,6,8.

Dimensional drawing

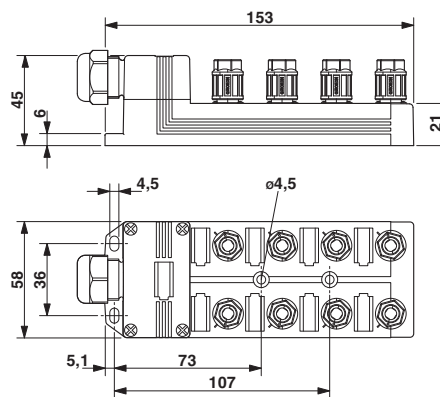

Sensor/actuator box - SACB- 8/3-C QO-0,34 - 1548370

Circuit diagram

