

REV.	ECN NO.	LOCATION	DESCRIPTION	DATE	DESIGN
X1			INITIAL RELEASE	2022.02.19	Liangkeyao
X3		①/X3	增加编码电镀规格	2022.12.20	Tanghaibo
X4		①/X4	修改编码电镀选项	2023.02.18	Tanghaibo
X5		①/X5	图面增加尺寸	2023.06.01	Tanghaibo

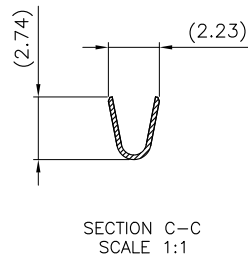

PART NUMBER INFORMATION:
5600BG-001R * * R * 0000

- RESERVE NUMBER
- BOX MARK:
 - 1: WITH DEREN LOGO
 - 2: WITHOUT DEREN LOGO
- PACKAGE CODE:
- R: REEL
- PLATING CODE:
 - 4: Au:15u"
 - 6: Sn:OVER TIN
- WIRE RANGE:
 - 1:28~30AWG
 - 2:22~28AWG
 - 3:18~22AWG

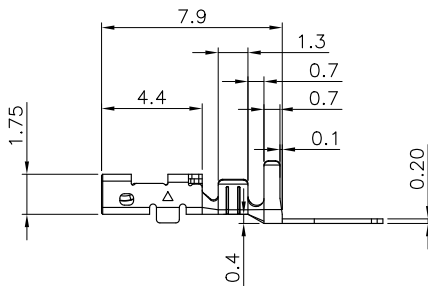
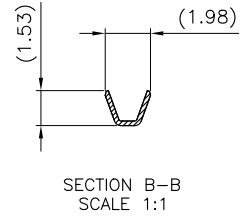
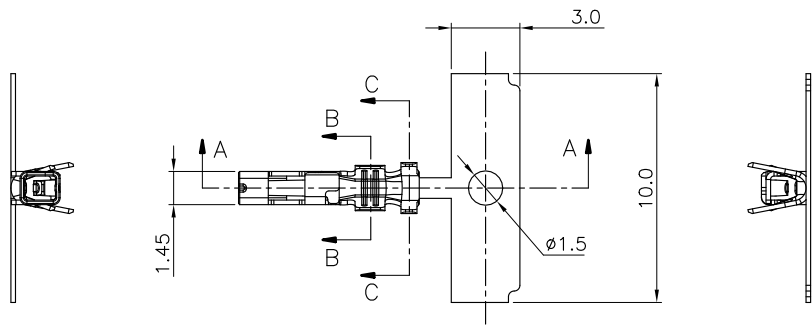
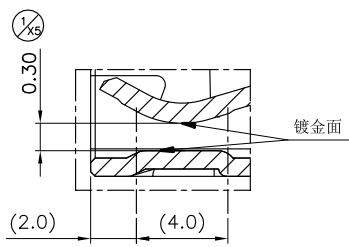
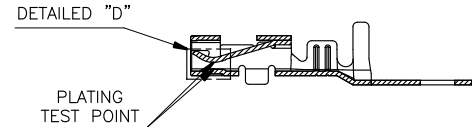
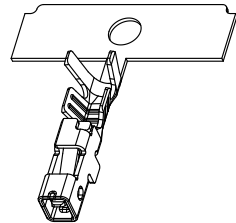

- NOTES:
- MATERIAL: COPPER ALLOY, T=0.20mm
 - FINISH: SEE PART NUMBER INFORMATION MIN. Au TIN PLATING ON CONTACT AREA. 50u" [1.27um] MIN. NICKEL UNDERPLATING ON ALLOVER AREA.
 - WIRE RANGE:SEE PART NUMBER INFORMATION
 - SALT SPRAY: 24hours.

SECTION A-A
SCALE 1:1

DETAILED "D"
SCALE 4:1

DIM	TOL	DIM	TOL
.x.	±0.30	.x.	±3*
.x	±0.30	.x	±3*
.xx	±0.30		

DEREN
SHENZHEN DEREN ELECTRONIC CO., LTD

CUSTOMER DRAWING		DATE	TITLE: WTb STD CONTACT PLATING	
DESIGN: tanghaibo		2023.06.01	P/N: 5600BG-001R**R*0000	
CHECK:			SHEET: 1/1	①
REV. X5	APPROVAL:		SCALE: 1:1	UNIT: mm