

- ★ Green Device Available
- ★ Excellent CdV/dt effect decline
- ★ 100% EAS Guaranteed
- ★ Advanced VD MOSFETS

## Product Summary

BVDSS	RDSON	ID
500V	1.45Ω	5A

## Applications

The 5N50 is the Advanced VD N-ch MOSFETS, which provide excellent RDSON and gate charge for most of the synchronous buck converter applications.

The 5N50 meet the RoHS and Green Product requirement 100% EAS guaranteed with full function reliability approved.

## TO252 Pin Configuration

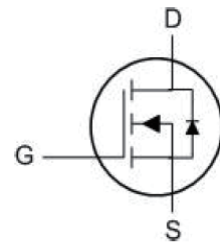
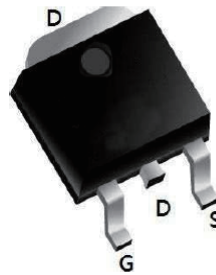

## Absolute Maximum Ratings

Symbol	Parameter	Max.	Units
V <sub>DSS</sub>	Drain-Source Voltage	500	V
V <sub>GSS</sub>	Gate-Source Voltage	±30	V
I <sub>D</sub>	Continuous Drain Current	T <sub>C</sub> = 25°C	5
		T <sub>C</sub> = 100°C	2.6*
I <sub>DM</sub>	Pulsed Drain Current <small>note1</small>	20*	A
EAS	Single Pulsed Avalanche Energy <small>(Note 2)</small>	167	mJ
I <sub>AR</sub>	Avalanche Current <small>(Note 1)</small>	5	A
EAR	Repetitive Avalanche Energy <small>(Note 1)</small>	10.6	mJ
dv/dt	Peak Diode Recovery dv/dt <small>(Note 3)</small>	5	V/ns
P <sub>D</sub>	Power Dissipation	T <sub>C</sub> = 25°C	24.5
		Derate above 25°C	0.2
T <sub>L</sub>	Maximum lead temperature for soldering purposes, 1/8" from case for 5 seconds	300	°C/W
T <sub>J</sub> , T <sub>STG</sub>	Operating and Storage Temperature Range	-55 To 150	°C

## Thermal Data

Symbol	Parameter	Value	Units
R <sub>θJC</sub>	Thermal Resistance, Junction-to-Case	4.2	°C/W
R <sub>θJS</sub>	Thermal Resistance, Case-to-Sink Typ.	--	°C/W
R <sub>θJA</sub>	Thermal Resistance, Junction-to-Ambient	48.2	°C/W

**Electrical Characteristics ( $T_J = 25^\circ\text{C}$  unless otherwise specified)**

Symbol	Parameter	Test Condition	Min.	Typ.	Max.	Units
<b>Static Characteristics</b>						
$BV_{DSS}$	Drain-Source Breakdown Voltage	$V_{GS} = 0\text{ V}, I_D = 250\ \mu\text{A}$	500	-	-	V
$\Delta BV_{DSS}/\Delta T_J$	Breakdown Voltage Temperature Coefficient	$I_D = 250\ \mu\text{A}$ , Referenced to $25^\circ\text{C}$	-	0.49	-	$V/^\circ\text{C}$
$I_{DSS}$	Zero Gate Voltage Drain Current	$V_{DS} = 500\text{ V}, V_{GS} = 0\text{ V}$	-	-	1	$\mu\text{A}$
		$V_{DS} = 400\text{ V}, TC = 125^\circ\text{C}$	-	-	10	$\mu\text{A}$
$I_{GSSF}$	Gate-Body Leakage Current, Forward	$V_{GS} = 30\text{ V}, V_{DS} = 0\text{ V}$	-	-	100	nA
$I_{GSSR}$	Gate-Body Leakage Current, Reverse	$V_{GS} = -30\text{ V}, V_{DS} = 0\text{ V}$	-	-	-100	nA
<b>On Characteristics</b>						
$V_{GS(TH)}$	Gate Threshold voltage	$V_{DS} = V_{GS}, I_D = 250\ \mu\text{A}$	2	-	4	V
$R_{DS(On)}$	Drain-Source on-state resistance	$V_{GS} = 10\text{ V}, I_D = 2\text{ A}, T_J = 25^\circ\text{C}$	-	1.45	1.8	$\Omega$
$g_{FS}$	Forward Transconductance	$V_{DS} = 40\text{ V}, I_D = 2.5\text{ A}$ (Note 4)	-	2.9	-	S
<b>Dynamic Characteristics</b>						
$C_{iss}$	Input capacitance	$V_{DS} = 25\text{ V}, V_{GS} = 0\text{ V},$ $f = 1.0\text{ MHz}$	-	415	-	pF
$C_{oss}$	Output capacitance		-	58	-	pF
$C_{riss}$	Reverse transfer capacitance		-	1.4	-	pF
<b>Switching Characteristics</b>						
$t_{d(on)}$	Turn On Delay Time	$V_{DD} = 250\text{ V}, I_D = 5\text{ A},$ $R_G = 25\ \Omega$ (Note 4, 5)	-	7	-	ns
$t_r$	Rising Time		-	22	-	ns
$t_{d(off)}$	Turn Off Delay Time		-	15	-	ns
$t_f$	Fall Time		-	23	-	ns
$Q_g$	Total Gate Charge		$V_{DS} = 400\text{ V}, I_D = 5\text{ A},$ $V_{GS} = 10\text{ V}$ (Note 4, 5)	-	13	-
$Q_{gs}$	Gate-Source Charge	-		4.9	-	nC
$Q_{gd}$	Gate-Drain Charge	-		2.3	-	nC
<b>Drain-source Diode Characteristics and Maximum Ratings</b>						
$I_S$	Maximum continuous Drain-source Diode Forward Current		-	-	5	A
$I_{SM}$	Maximum Pulsed Drain-Source Diode Forward Current		-	-	20	A
$V_{SD}$	Diode Forward Voltage	$V_{GS} = 0\text{ V}, I_S = 5\text{ A}$	-	-	1.2	V
$t_{rr}$	Reverse Recovery Time	$V_{GS} = 0\text{ V}, I_S = 5\text{ A},$	-	289	-	ns
$Q_{rr}$	Reverse Recovery Charge	$dI_F / dt = 100\text{ A}/\mu\text{s}$ (Note 4)	-	1.2	-	$\mu\text{C}$

**Notes:**

1. Repetitive Rating : Pulse width limited by maximum junction temperature
2.  $L = 10.6\text{ mH}, I_{AS} = 5\text{ A}, V_{DD} = 50\text{ V}, R_G = 25\ \Omega$ , Starting  $T_J = 25^\circ\text{C}$
3.  $I_{SD} \leq 5\text{ A}, di/dt \leq 200\text{ A}/\mu\text{s}, V_{DD} \leq BV_{DSS}$ , Starting  $T_J = 25^\circ\text{C}$
4. Pulse Test : Pulse width  $\leq 300\ \mu\text{s}$ , Duty cycle  $\leq 2\%$
5. Essentially independent of operating temperature

Typical Electrical and Thermal Characteristics (Curves)

Figure 1: Output Characteristics

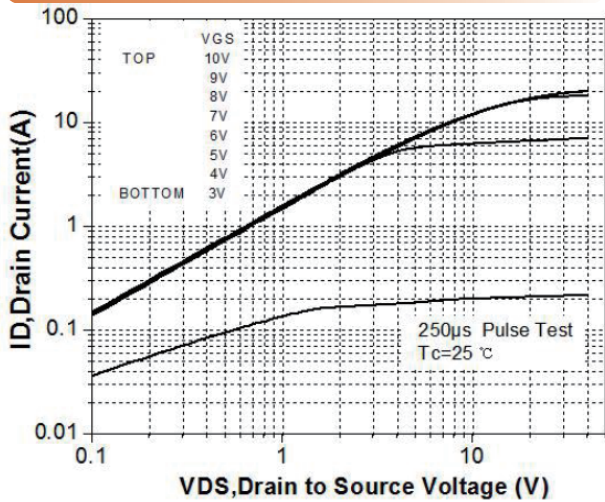

Figure 2: Typical Transfer Characteristics

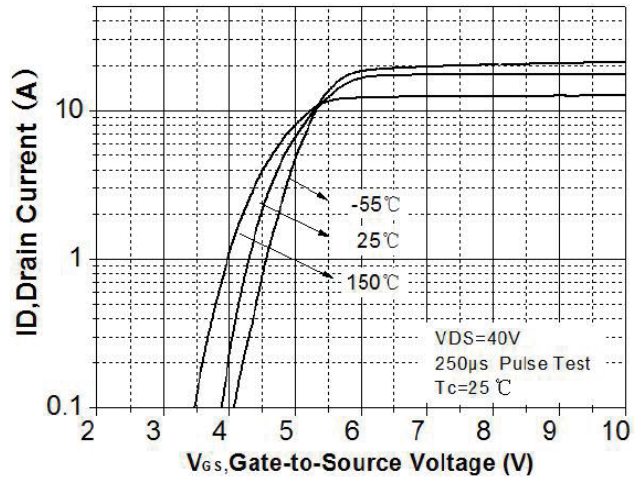

Figure 3: On-resistance vs. Drain Current

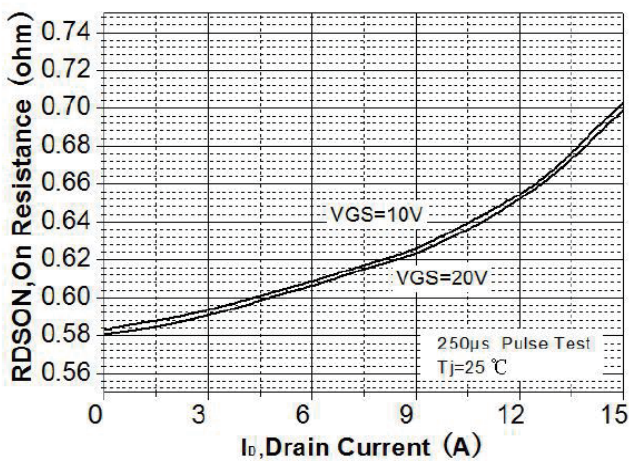

Figure 4: Body Diode Characteristics

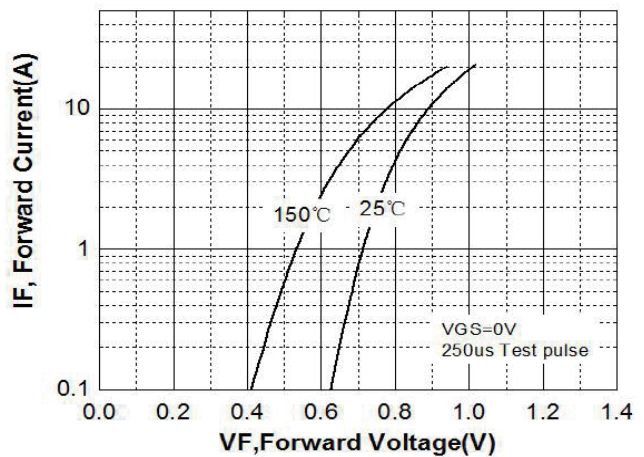

Figure 5: Capacitance Characteristics

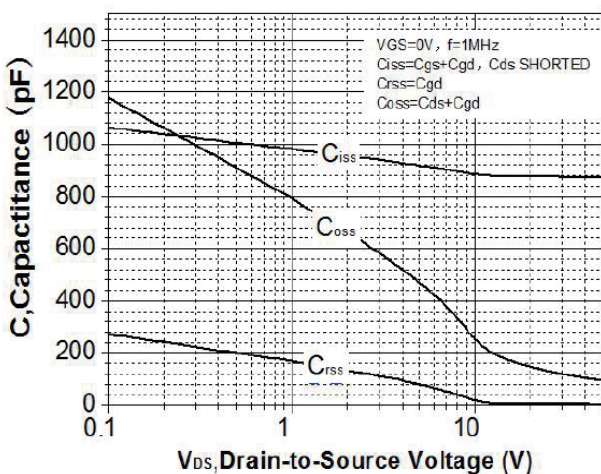
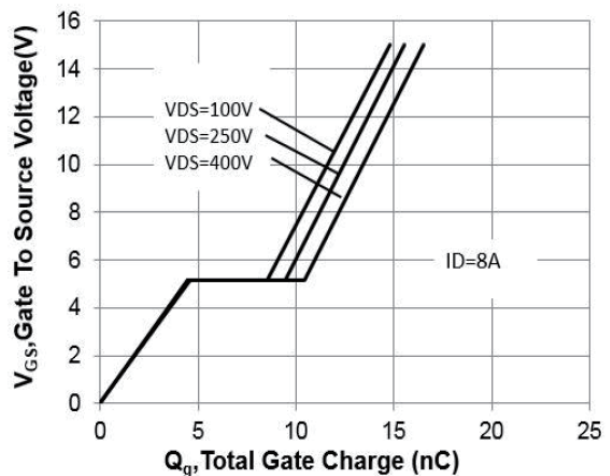

Figure 6: Gate Charge Characteristics



Typical Performance Characteristics

Figure 7: Breakdown Voltage Variation

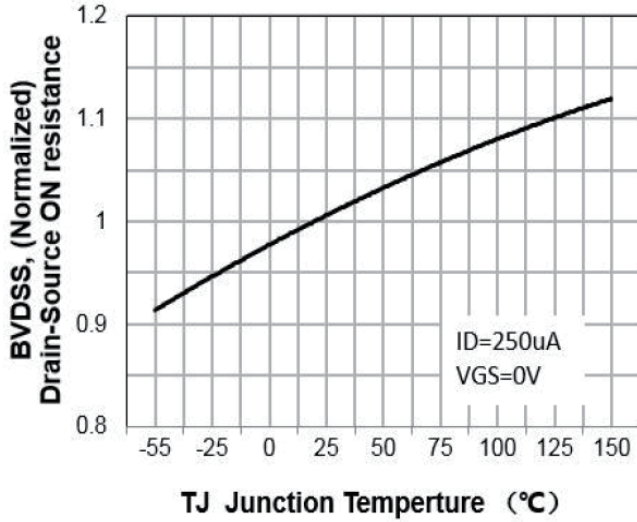

Figure 8: On-Resistance Variation

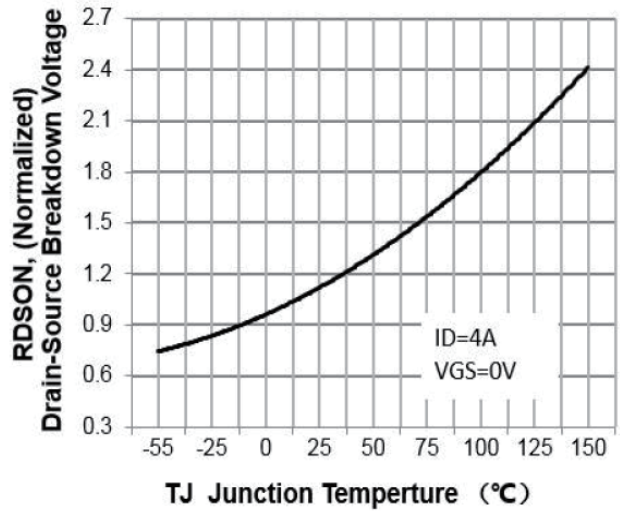

Figure 9: Maximum Safe Operating Area

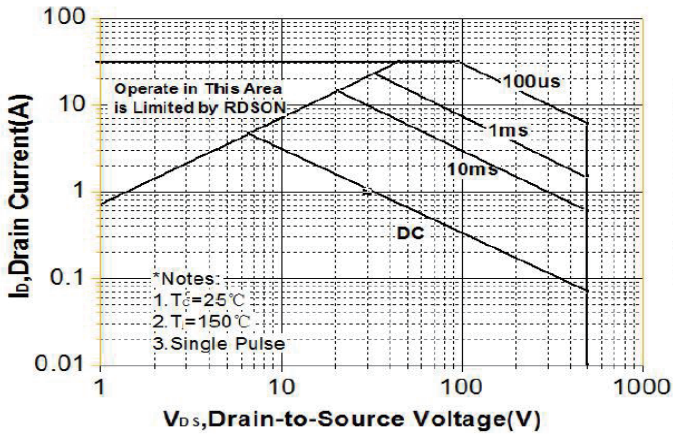

Figure 10: Maximum Drain Current

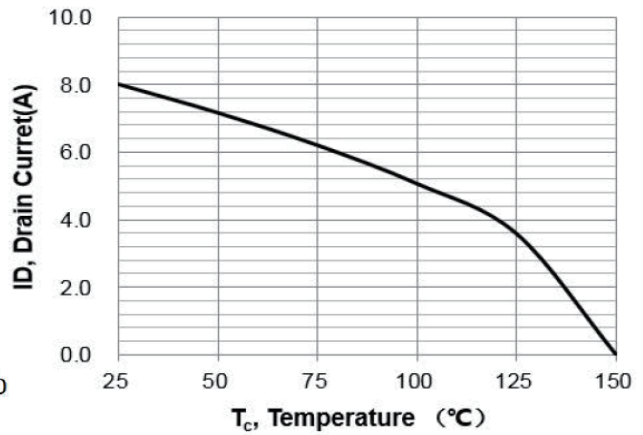
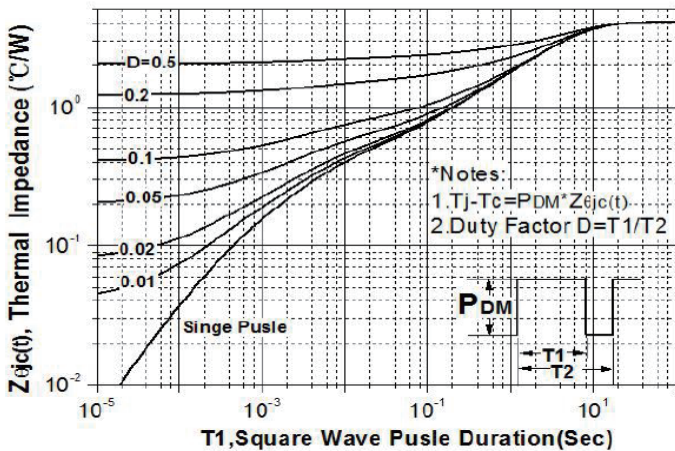
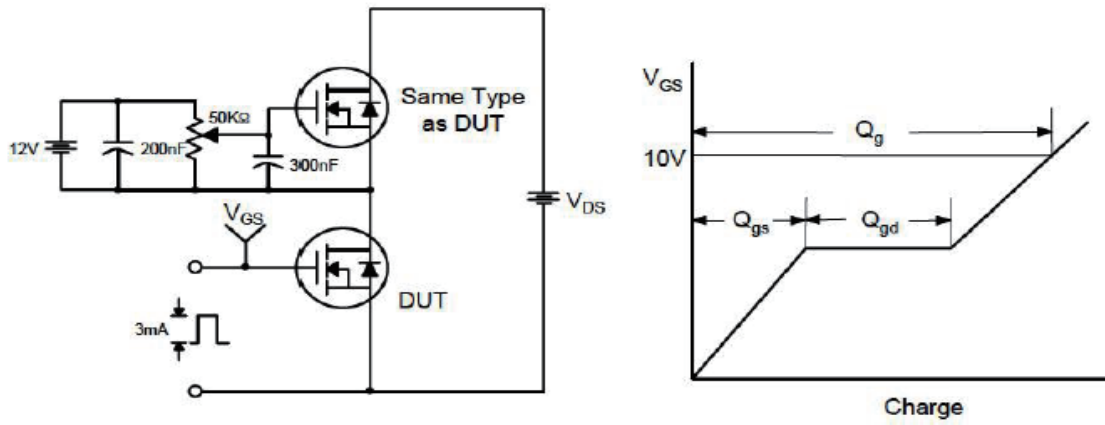

Figure 11: Transient Thermal Response



Test circuit

Gate Charge Test Circuit & Waveform



Resistive Switching Test Circuit & Waveforms

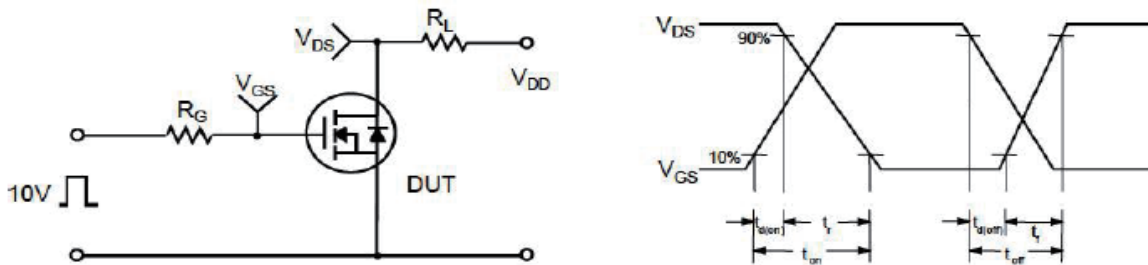

Unclamped Inductive Switching Test Circuit & Waveforms

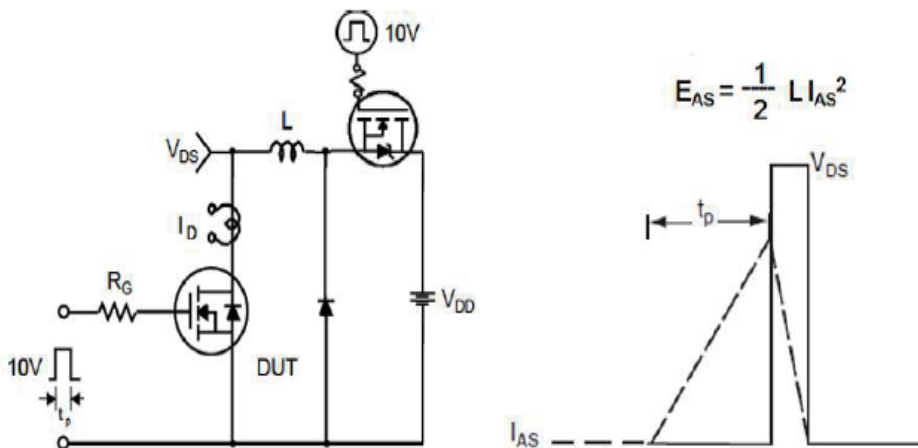

Package Mechanical Data-TO-252

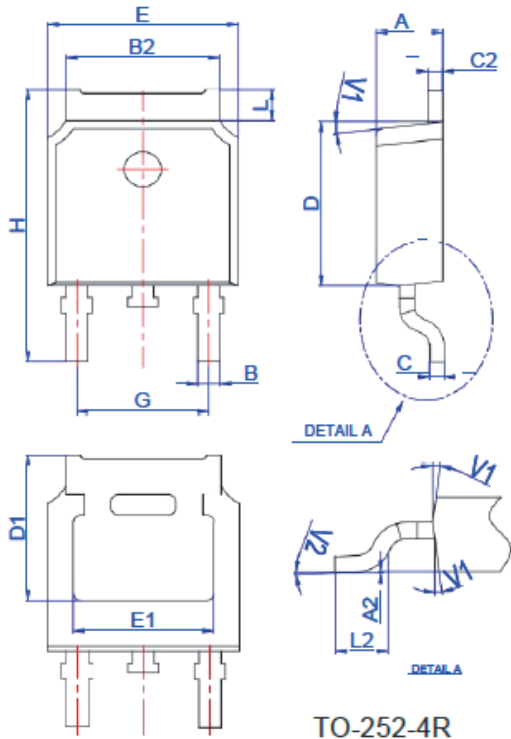

Ref.	Dimensions					
	Millimeters			Inches		
	Min.	Typ.	Max.	Min.	Typ.	Max.
A	2.10		2.50	0.083		0.098
A2	0		0.10	0		0.004
B	0.66		0.86	0.026		0.034
B2	5.18		5.48	0.202		0.216
C	0.40		0.60	0.016		0.024
C2	0.44		0.58	0.017		0.023
D	5.90		6.30	0.232		0.248
D1	5.30REF			0.209REF		
E	6.40		6.80	0.252		0.268
E1	4.63			0.182		
G	4.47		4.67	0.176		0.184
H	9.50		10.70	0.374		0.421
L	1.09		1.21	0.043		0.048
L2	1.35		1.65	0.053		0.065
V1		7°			7°	
V2	0°		6°	0°		6°

Reel Specification-TO-252

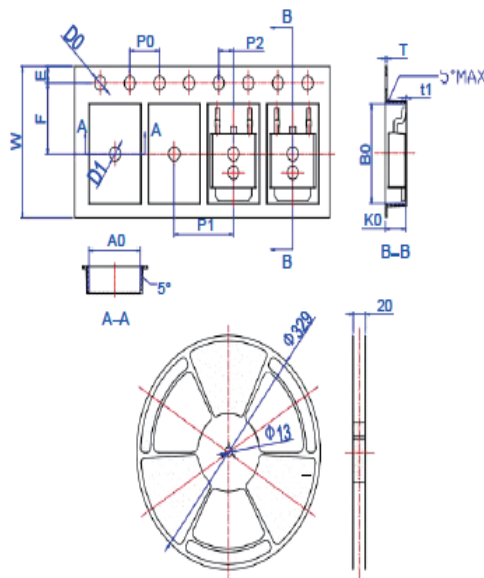

Ref.	Dimensions					
	Millimeters			Inches		
	Min.	Typ.	Max.	Min.	Typ.	Max.
W	15.90	16.00	16.10	0.626	0.630	0.634
E	1.65	1.75	1.85	0.065	0.069	0.073
F	7.40	7.50	7.60	0.291	0.295	0.299
D0	1.40	1.50	1.60	0.055	0.059	0.063
D1	1.40	1.50	1.60	0.055	0.059	0.063
P0	3.90	4.00	4.10	0.154	0.157	0.161
P1	7.90	8.00	8.10	0.311	0.315	0.319
P2	1.90	2.00	2.10	0.075	0.079	0.083
A0	6.85	6.90	7.00	0.270	0.271	0.276
B0	10.45	10.50	10.60	0.411	0.413	0.417
K0	2.68	2.78	2.88	0.105	0.109	0.113
T	0.24		0.27	0.009		0.011
t1	0.10			0.004		
10P0	39.80	40.00	40.20	1.567	1.575	1.583