

30V P-Channel Enhancement Mode MOSFET

Description

The NP4419SR uses advanced trench technology and design to provide excellent $R_{DS(ON)}$ with low gate charge. It can be used in load switch and battery protection applications.

General Features

- ◆ $V_{DS} = -30V$, $I_D = -9.0A$
 $R_{DS(ON)}(Typ.) = 16m\Omega$ @ $V_{GS} = -10V$
 $R_{DS(ON)}(Typ.) = 21m\Omega$ @ $V_{GS} = -4.5V$
- ◆ High power and current handing capability
- ◆ Lead free product is acquired
- ◆ Surface mount package

Application

- ◆ Battery protection
- ◆ Load switch

Package

- ◆ SOP-8 *100% UIS TESTED!*
100% ΔV_{ds} TESTED!

Schematic diagram

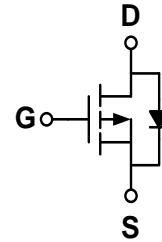

Marking and pin assignment

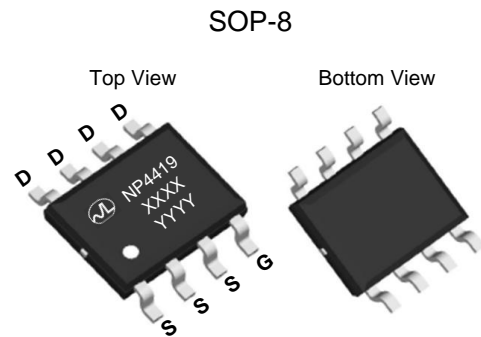

Note: XXXX is the date code
 YYYY is the Quality Code.



Ordering Information

Part Number	Storage Temperature	Package	Devices Per Reel
NP4419SR-G	-55°C to +150°C	SOP8	4000

Absolute Maximum Ratings (TA=25°C unless otherwise noted)

parameter	symbol	limit	unit
Drain-source voltage	V_{DS}	-30	V
Gate-source voltage	V_{GS}	±20	V
Drain current-continuous ^a @ $T_j = 125^\circ C$ -pulse ^b	I_D	-9.0	A
	I_{DM}	-40	A
Drain-source Diode forward current	I_S	-2.5	A
Maximum power dissipation	P_D	1.5	W
Operating junction Temperature range	T_j	-55—150	°C

Electrical Characteristics (TA=25°C unless otherwise noted)

Parameter	Symbol	Condition	Min	Typ	Max	Unit
OFF Characteristics						
Drain-source breakdown voltage	BV_{DSS}	$V_{GS}=0V, I_D=-250\mu A$	-30	-	-	V
Zero gate voltage drain current	I_{DSS}	$V_{DS}=-30V, V_{GS}=0V$	-	-	-1	μA
Gate-body leakage	I_{GSS}	$V_{DS}=0V, V_{GS}=\pm 20V$	-	-	± 100	nA
ON Characteristics						
Gate threshold voltage	$V_{GS(th)}$	$V_{DS}=V_{GS}, I_D=-250\mu A$	-1.00	-1.67	-3.0	V
Drain-source on-state resistance	$R_{DS(on)}$	$V_{GS}=10V, I_D=-9A$	-	16	22	m Ω
		$V_{GS}=4.5V, I_D=-7A$	-	21	28	
Forward transconductance	gfs	$V_{GS}=-5V, I_D=-9A$	-	24	-	S
Dynamic Characteristics						
Input capacitance	C_{ISS}	$V_{DS}=-15V, V_{GS}=0V$ $f=1.0MHz$	-	1040	1250	pF
Output capacitance	C_{OSS}		-	180	-	
Reverse transfer capacitance	C_{RSS}		-	125	175	
Switching Characteristics						
Turn-on delay time	$t_{D(ON)}$	$V_{DS}=-15V$ $R_L=2.2\Omega$ $V_{GS}=-10V$ $R_{GEN}=3\Omega$	-	10	-	ns
Rise time	t_r		-	5.5	-	
Turn-off delay time	$t_{D(OFF)}$		-	26	-	
Fall time	t_f		-	9	-	
Total gate charge	$Qg(10V)$	$V_{DS}=-15V, I_D=-9A$ $V_{GS}=-10V$	-	19	-	nC
Total gate charge	$Qg(4.5V)$		-	9.6	-	
Gate-source charge	Qgs		-	3.6	-	
Gate-drain charge	Qgd		-	4.6	-	
DRAIN-SOURCE DIODE CHARACTERISTICS						
Diode forward voltage	V_{SD}	$V_{GS}=0V, I_S=-1.0A$	-	-0.75	-1.0	V

Notes:

- a. The value of $R_{th JA}$ is measured with the device mounted on 1in² FR-4 board with 2oz. Copper, in a still air environment with TA =25 °C. The value in any given application depends on the user's specific board design.
- b. The power dissipation P_D is based on $T_{J(MAX)}=150^\circ C$, using $\leq 10s$ junction-to-ambient thermal resistance.

Thermal Characteristics

Thermal Resistance junction-to ambient	$R_{th JA}$	90	$^\circ C/W$
--	-------------	----	--------------

Typical Performance Characteristics

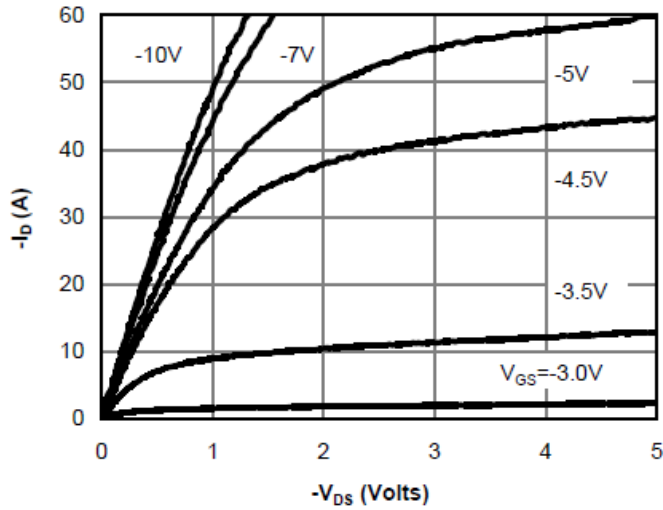

Fig 1: On-Region Characteristics (Note E)

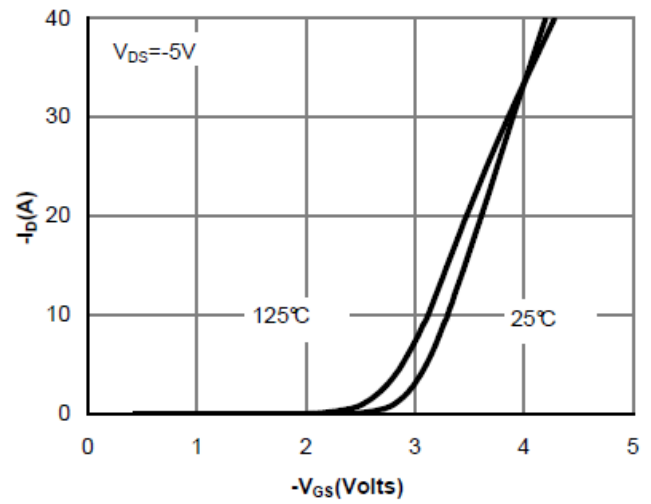

Figure 2: Transfer Characteristics (Note E)

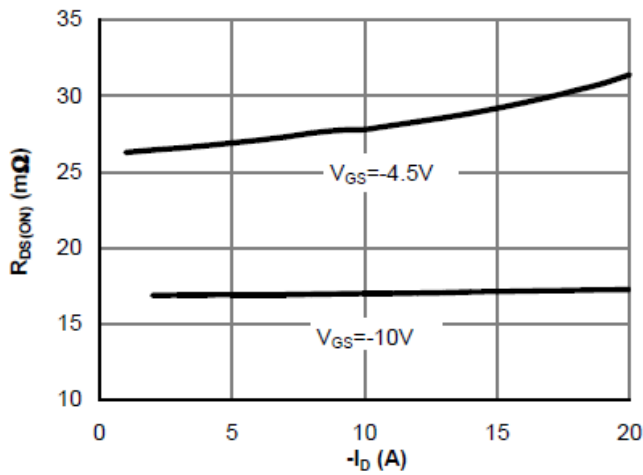

Figure 3: On-Resistance vs. Drain Current and Gate Voltage (Note E)

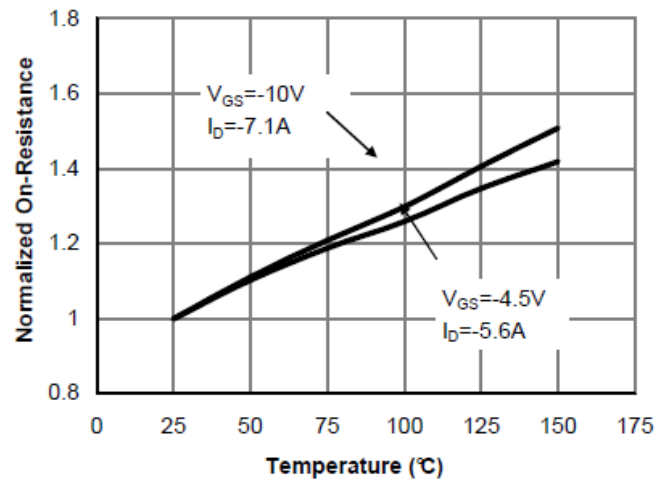

Figure 4: On-Resistance vs. Junction Temperature (Note E)

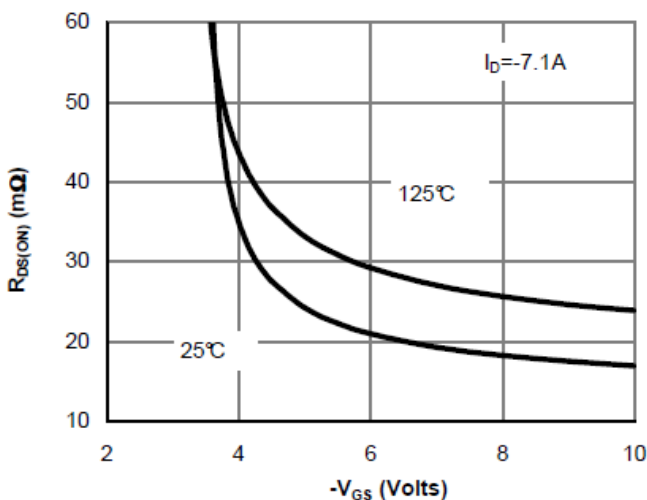

Figure 5: On-Resistance vs. Gate-Source Voltage

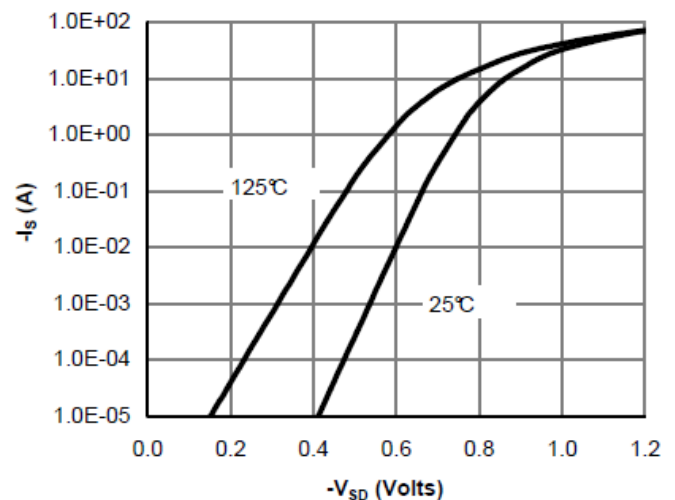

Figure 6: Body-Diode Characteristics (Note E)

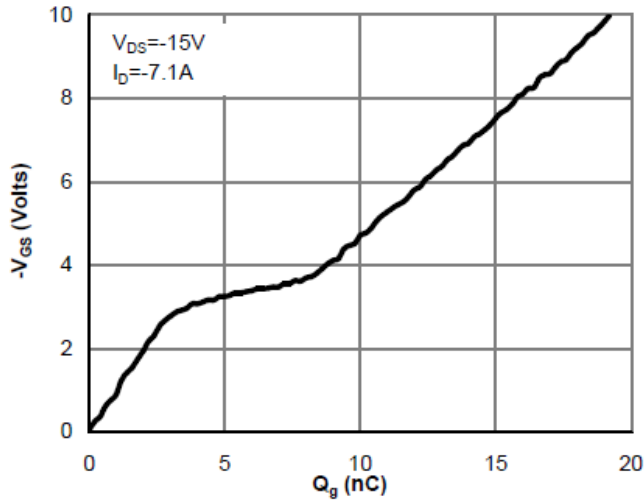

Figure 7: Gate-Charge Characteristics

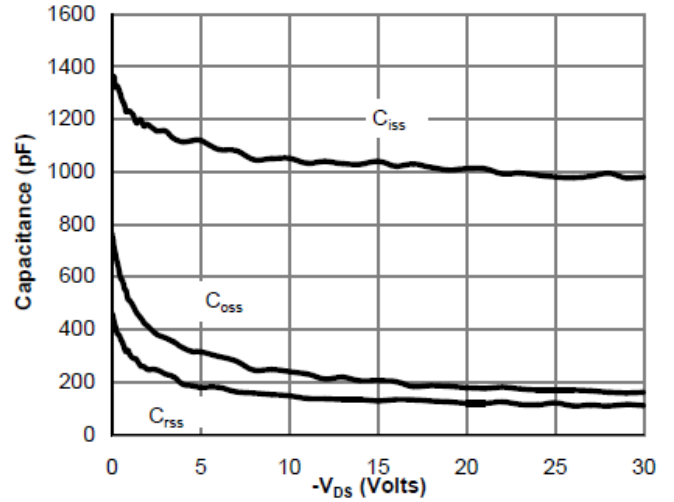

Figure 8: Capacitance Characteristics

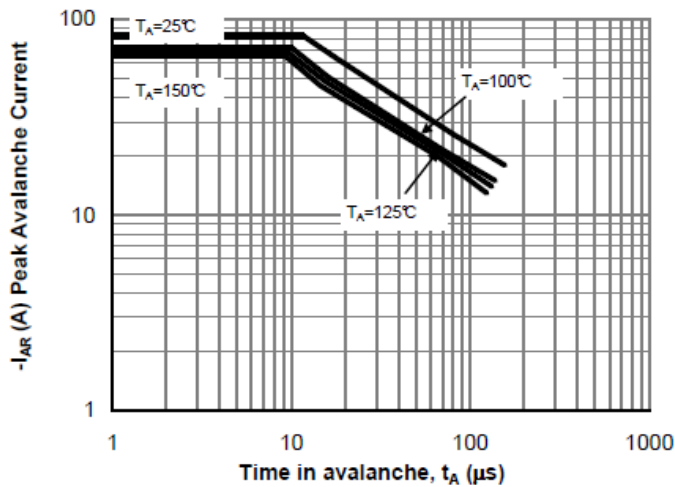

Figure 9: Single Pulse Avalanche capability (Note C)

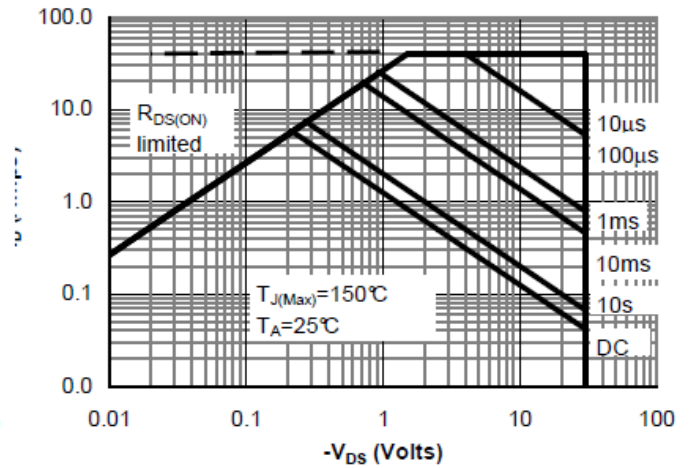

Figure 10: Maximum Forward Biased Safe Operating Area (Note F)

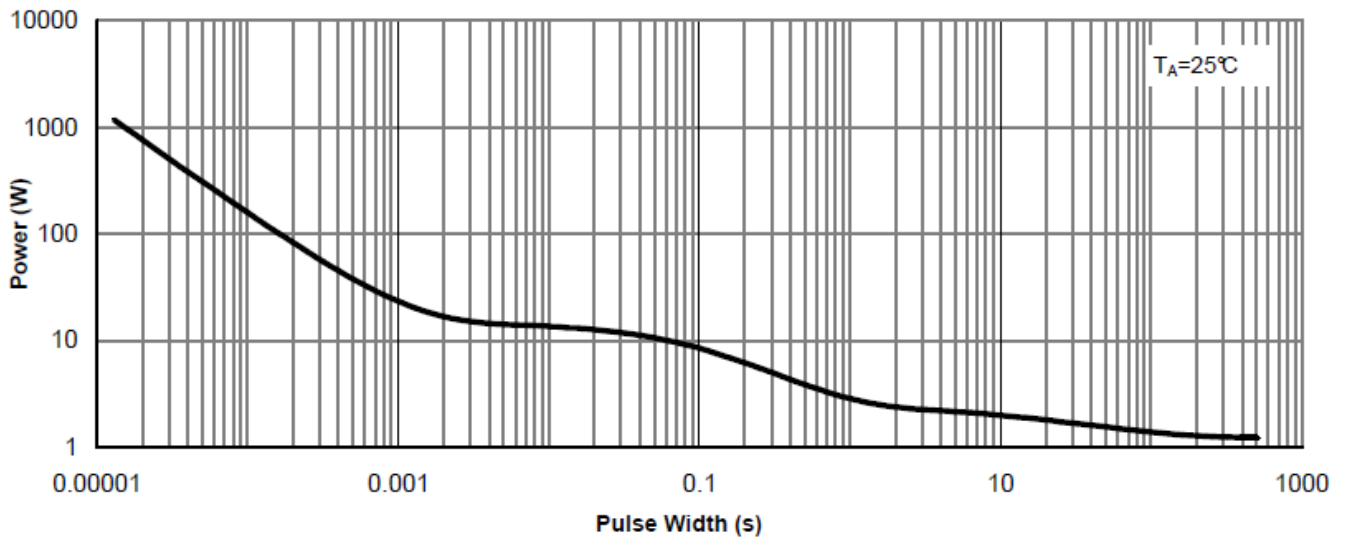
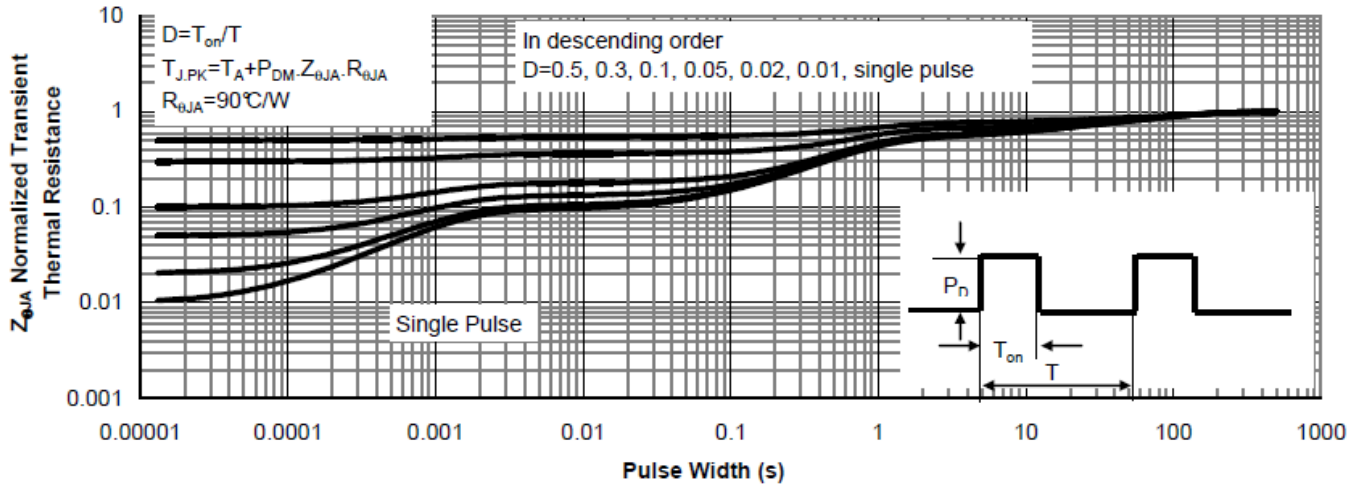
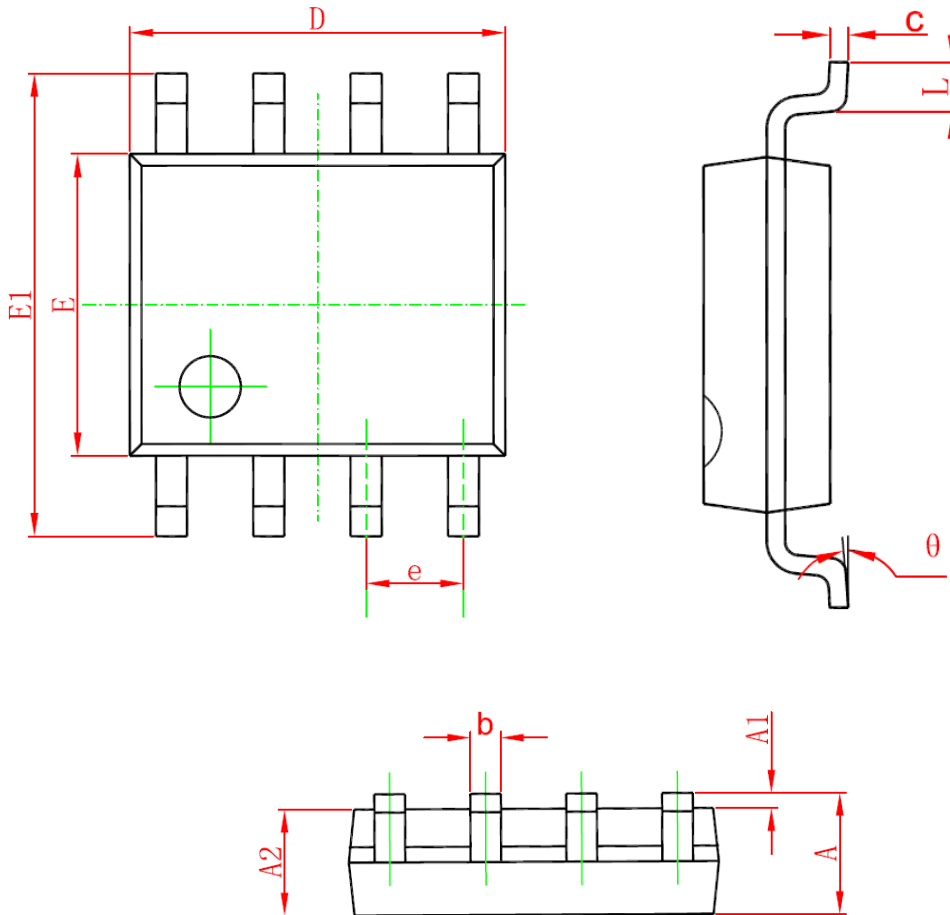

Figure 11: Single Pulse Power Rating Junction-to-Ambient (Note F)



Package Information

- SOP-8



Symbol	Dimensions In Millimeters		Dimensions In Inches	
	Min	Max	Min	Max
A	1.350	1.750	0.053	0.069
A1	0.100	0.250	0.004	0.010
A2	1.350	1.550	0.053	0.061
b	0.330	0.510	0.013	0.020
c	0.170	0.250	0.006	0.010
D	4.700	5.100	0.185	0.200
E	3.800	4.000	0.150	0.157
E1	5.800	6.200	0.228	0.244
e	1.270 (BSC)		0.050 (BSC)	
L	0.400	1.270	0.016	0.050
θ	0°	8°	0°	8°

Recommended Minimum Pads

- SOP-8

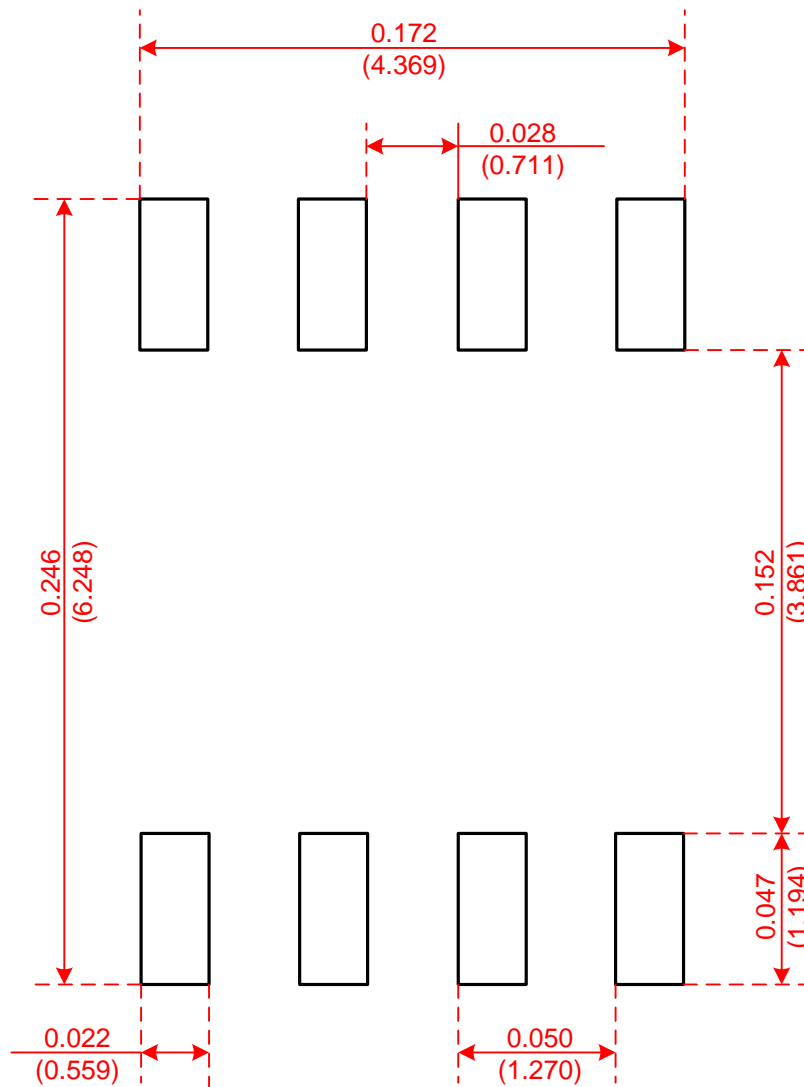

Recommended Minimum Pads
Dimensions in Inches/(mm)

Tape and Reel

- SOP-8

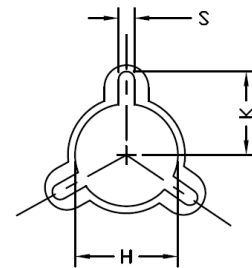
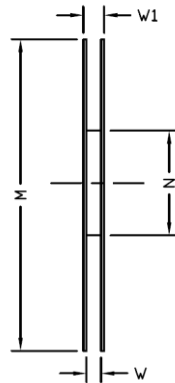
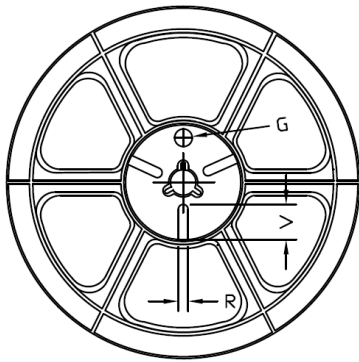
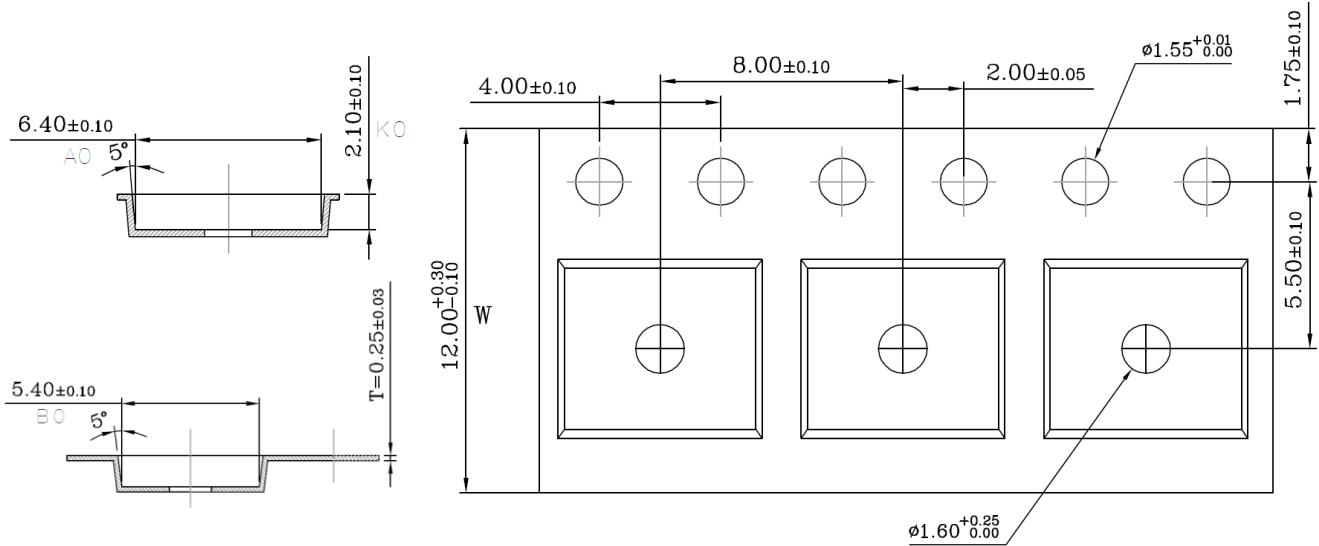

Tape Size	Reel Size	M	N	W	W1	H	K	S	G	R	V
12mm	$\phi 330$	$\phi 330.00$ ± 0.50	$\phi 97.00$ ± 0.30	13.00 ± 0.30	17.40 ± 1.00	$\phi 13.00$ ± 0.5	10.6	2.00 ± 0.50	—	—	—

Unit Per Reel:
4000pcs

