

Embest AT91SAM3U ARM-CM3 Board User Guide



EMBEST CO., LIMITED

Address: Room 509, Luohu Science & Technology Building,
No.85, Taining Road, Shenzhen, Guangdong, China 518020

Telephone: 0086-755-25621715 or 25635626 ext.1715

Fax: 0086-755-25616057

Sales Email: sales.en@embedinfo.com

Support Email: support.en@embedinfo.com

Website: <http://www.embedinfo.com/en>

AT91SAM3U4E Chips Based on Atmel ARM Cortex-M3 Kernel

The AT91SAM3U ARM-CM3 Board is an ARM embedded evaluation board produced by Embest, integrates the ATMEL Cortex-M3 core-based processor AT91SAM3U4E, operating at 84 MHz frequency, with internal 256KB flash, 48KB SRAM. The board features USB, I2C, MCI interface, TFT-LCD, USART interface, 96 I/O port, EBI support SRAM/NOR/NAND memory, etc. Plenty of software examples, which can be used in Keil MDK environment, are accompanied in CDROM.

Deliverables

The AT91SAM3U ARM-CM3 toolkit contains the following items:

- a AT91SAM3U ARM-CM3 Board
- power supply
- universal input AC/DC power supply with US, Europe and UK plug adapters
- one 3V Lithium Battery type CR1225
- one USB cable
- one serial RS232 cable

Content

1. Jumper	4
2. Evaluation Board Hardware.....	5
2.1 Board Overview	5
2.2 Block Diagram	6
2.3 Processor	6
2.4 Memory	6
2.5 Clock Circuitry	6
2.6 Reset and Wake-Up Circuitry	7
2.7 Power Supply and Management	7
2.8 UART.....	7
2.9 USART	7
2.10 LED.....	8
2.11 LCD Backlight Control and Touch Panel.....	8
2.12 JTAG	8
2.13 Audio Codec	9
2.14 USB	9
2.15 ADC	9
2.16 User Buttons.....	10
2.17 Temperature Sensor	10
2.18 SD Card	10
2.19 PIO Expansion.....	10
2.20 Hardware Testing	11

1. Jumper

The AT91SAM3U ARM-CM3 Board jumpers are used for many purposes such as internal Flash Memory re-initialization, power current measurement and other configurations.

Table 1. Jumpers Setting

Designation	Label	Default Setting	Feature
JP1	ERASE	Open	Close it to reinitialize the Flash content and some of its NVM bits. This jumper must be closed for more than 220 ms at power-up to perform the re-initialization.
JP2(DNP)	TEST	Not populated (open)	reserved
JP3	VIN	Close	Measure current feed into VDDIN pin
JP5	AD12B VREF	Pin1 Pin2 close, Switch to +3V3	Select the reference voltage of the 12-bit ADC to be either 3.3V (close 1-2) or 2.5V (close 2-3)
JP6	VIO	Close	Measure current feed into VDDIO pins
JP7	VUTMI	Close	Measure current feed into VDDUTMI pin
JP8	VANA	Close	Measure current feed into VDDANA pin
JP9	VCORE	Close	Measure current feed into VDDCORE pins
JP10	VPLL	Close	Measure current feed into VDDPLL pin
JP11	VOUT	Close	Measure current out of VDDOUT pin
JP12	NCS0	Close	Disconnection possibility on NCS0
JP13	NCS1	Close	Disconnection possibility on NCS1
JP14	NCS2	Close	Disconnection possibility on NCS2
JP15	3AXS	Open	G-select feature, sensitivity level switch. Close as 440mv/g, open as 117.5mV/g
JP16	3AXS	Open	Close to cause a slight deflect on each axis output, which is device self test
JP17	FORCE POWER ON	Open	Close to force +3V3 LDO output valid
JP18(DNP)		Not populated (open)	Close to enable 50-Ohm terminal resistor for AD12BAD3 BNC port
JP19(DNP)		Not populated (open)	Close to enable 50-Ohm terminal resistor for AD0 BNC port
JP20	ADVRE F	Pin1 Pin2 close, Switch to +3V3	Select the reference voltage of the 10-bit ADC to be either 3.3V (close 1-2) or 2.5V (close 2-3)
JP21		Open	Measure current feed into ZigBee module

2. Evaluation Board Hardware

2.1 Board Overview

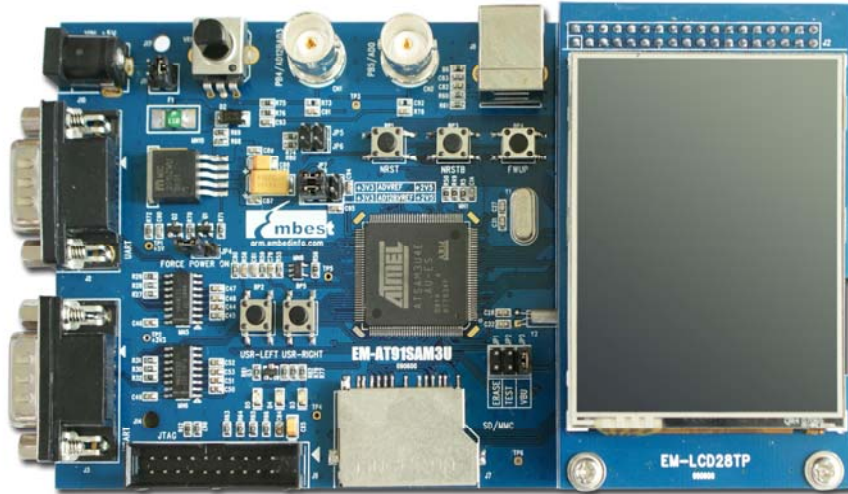
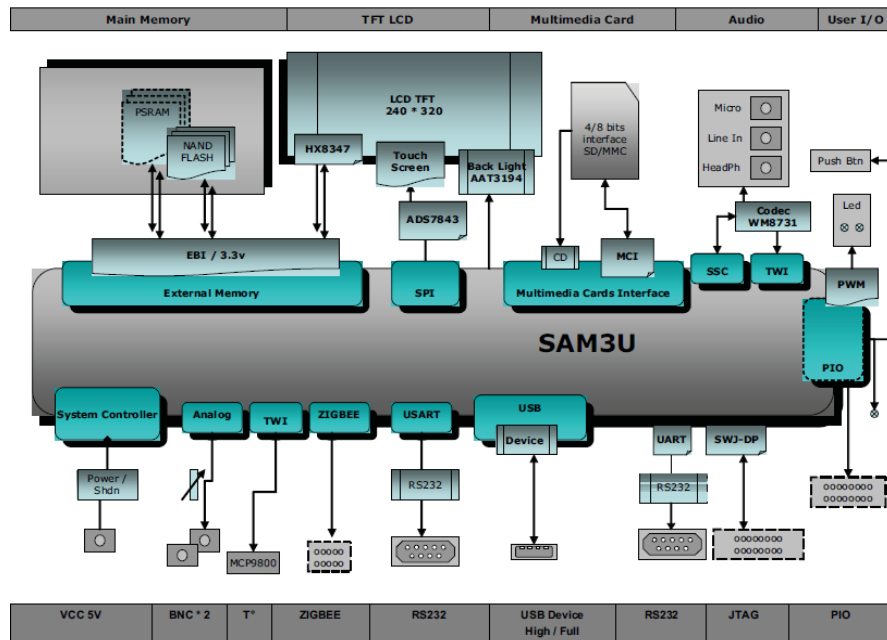

Table 2. A List of Hardware Interfaces

J1	External Clock Input Connector	MN3	NAND Flash
J2	LCD connector	MN4	AAT3194 charge pump DC / DC converters
J3	UART DB9 male connector	MN5	Touch Screen controller
J4	USART DB9 male connector	MN6	RS232 Transceiver 1
J5	HEADPHONE LINE-OUT	MN7	RS232 Transceiver 2
J6	Audio LINE-IN	MN8	WM8731 CODEC
J7	MONO/STEREO MICRO INPUT	MN9	G-Sensor
J8	SD/MMC Socket	MN10	Temperature Sensor
J9	USB Device(B-type) interface	MN11	USB Slave Device interface
J10	JTAG interface	MN12	Voltage Regulator
J11	Power JACK	MN13	PolyZen diode
J12	SAM3U LOFP144	MN14	LC combinatory filter
J13	PIOC external pins	MN15	LM4040-2.5 PNP
J14	PIOB external pins	BP1	NRST button
J15	PIOA external pins	BP2	NRSTB button
J16	ZigBee	BP3	FWUP button
CN1	BNC interface1 supporting ADC12B	BP4	USR-LEFT button
CN2	BNC interface2 supporting ADC0	BP5	USR-RIGHT button
MN1	SAM3 chip		
MN2	PSRAM		

2.2 Block Diagram



2.3 Processor

The Embest AT91SAM3U ARM-CM3 Board is equipped with a SAM3U4E processor in LQFP144 package.

2.4 Memory

The SAM3U4E chip embeds:

- 256 KB of embedded Flash
- 48 KB of embedded SRAM with dual bank
- 16 KB of ROM with embedded boot loader routines (UART, USB) and IAP (In-Application Programming functions) routines.

The SAM3U4E features an External Bus Interface (EBI) which permits connecting to a wide range of external memories and peripherals. The Embest AT91SAM3U board is equipped with two kinds of memory devices connected to the SAM3U4E EBI:

- One PSRAM (Micron MT45V512KW16PEGA 512K*16, 48-ball VFBGA), 16 bits data interface
- One NAND-Flash MT29F2G16ABD.

2.5 Clock Circuitry

The clock generator of a SAM3U4E microcontroller is made of:

- A Low Power 32,768 Hz Slow Clock Oscillator with bypass mode
- A 3 to 20 MHz Crystal Oscillator, which can be bypassed (12 MHz needed in case of connecting to USB interface)
- A factory programmed fast internal RC Oscillator. 3 output frequencies can be selected: 4, 8 or 12 MHz (default value is 4 MHz).

- A 480 MHz UTMI PLL providing a clock for the USB High Speed Device Controller
- A programmable PLL ranging from 96 to 192 MHz (input from 8 to 16 MHz), is capable of providing the clock MCK to the processor and to the peripherals.

The Embest AT91SAM3U board is equipped with one 12 MHz crystal, one 32,768 Hz crystal and an external clock input connector (optional, not populated by default).

2.6 Reset and Wake-Up Circuitry

The on-board NRST button BP1 and NRSTB button BP2 provide the SAM3U4E with external reset control. The on-board WAKE-UP button BP3 can be used to wake up the chip from low power modes.

2.7 Power Supply and Management

The Embest AT91SAM3U board is supplied with an external 5V DC block through input J11. Protection circuitry is obtained by a PolyZen diode MN13 and an LC combinatory filter MN14. The adjustable LDO regulator MN12 enables the voltage value to stable around 3.5V and it powers for all the 3.3V on-board components. The shut down control of this LDO is made of MOSFETs Q1, Q2 and is guided by the SAM3U4E SHDN pin. When SAM3U4E is in backup mode, SHDN pin will output a low level signal to shut down the LDO; when it is in the running mode (not in backup mode), SHDN pin will output a high level signal to run the LDO. When closing the "FORCE POWER ON" jumper JP17, the P-channel MOSFET Q1 will be forced on, and the LDO 3.3V will also be forced to output, no matter what level the SHDN Pin input.

2.8 UART

The Universal Asynchronous Receiver features a two-pin UART that can be used for communication and trace purposes. It offers an ideal channel for in-situ programming solutions. This UART is associated with two PDC channels to reduce the process time on packet handling.

This two-pin UART (TXD and RXD only) is buffered through an RS232 Transceiver MN6 and brought the result to the DB9 male connector J3.

2.9 USART

The Universal Synchronous/Asynchronous Receiver Transmitter (USART) provides one full duplex universal synchronous/asynchronous link circuit. The data frame is extensively configurable (such as data, data length, parity check and some stop bits, etc) to support a broad range of serial communication standards. The USART is also associated with PDC channels for TX/RX data access.

There are 3 USART on the Embest AT91SAM3U board. The board connects the USART1 bus (including TXD, RXD, RTS, and CTS handshake signals control) to the DB9 male connector

J4 through the RS232 Transceiver MN7.

2.10 LED

There are three LEDs on the Embest AT91SAM3U board:

D2 and D3 green LEDs are user-defined and controlled by the GPIO.

D4 red LED is a power LED indicating the voltage value is 3.3V. It can also be controlled by the GPIO (by default, the GPIO is disabled and the LED is lighted by an on-board 3.3V voltage).

2.11 LCD Backlight Control and Touch Panel

The Embest AT91SAM3U board carries one TFT-LCD module with touch screen - FTM280C12D which integrates the complete driver IC HX8347. The LCD display's size is 2.8 inches, with the resolution of 240 x 320 pixels.

Table3. LCD Module Pin Output

Pin	Symbol	Function	Pin	Symbol	Function
1	GND	Ground	27	Y+	Touch panel Y_UP
2	CS	Chip Select	28	X-	Touch panel Y_LEFT
3	RS	Register select signal	29	Y-	Touch panel Y_DOWN
4	WR	Write operation signal	30	GND	Ground
5	RD	Read operation signal	31	VDD1	Power supply for digital IO Pad
6~21	DB0~DB15	Data bus	32	VDD2	Power supply for analog circuit
22~23	NC	No connection	33~36	A1~A4	Power supply for backlight
24	RESET	Reset signal	37~38	NC	No connection
25	GND	Ground	39	K	Backlight ground
26	X+	Touch panel Y_RIGHT			

The LCD is reset through NRST, and JTAG interface and BP1 also use NRST. The LCD's chip selection pin connects to NCS2. SAM3U4E communicates with LCD through PIOB port, which complies with 16-bit parallel "8080-like" bus protocol.

The backlight of the LCD consists of 4 LEDs, its driver is AAT3194 (MN4). AAT3194 which is able to open, close and configure the brightness of the LED connects to SAM3U4E through S2C.

The LCD Unit integrates 4-wire touch screen which is controlled by ADS7843 (MN5), it is a slave device of SAM3U4E SPI bus. The IN3/IN4 pin of ADS7843 is used to extend the extra functions.

2.12 JTAG

The standard 20-pin JTAG connector of the board is able to connect to any ARM JTAG emulator, such as SAM-ICE.

2.13 Audio Codec

The Embest AT91SAM3U board includes a audio codec WM8731 for digital sound input and output. The function of the audio jacks is as follows:

- microphone input
- line audio input
- headphone output

The SAM3U4E programmable clock output is used to generate the WM8731 master clock (MCLK). The SAM3U4E ODT (On-Die Termination) feature guarantees a signal integrity on this clock line without the need for external discrete components.

WM8731 pin 21 MODE is pulled down by default; this configures the device as a TWI device for internal register access. Pin15 CSB is pulled up, which sets its TWI address as 33 [0x0011011].

The WM8731 digital interface works in slave mode on the SAM3U4E Synchronous Serial Controller (SSC) interface, which means that Codec digital audio bit clock and ADC/DAC left/right control clock are to be generated by the SAM3U4E.

Figure1. Codec Slave Mode

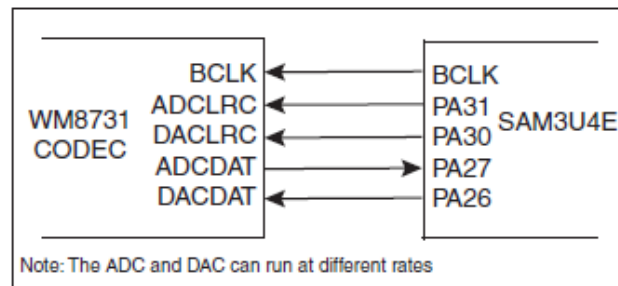

2.14 USB

The SAM3U4E UDPHS port is compliant with the Universal Serial Bus (USB) rev 2.0 High Speed device specification. J9 is a B-type receptacle for USB device.

Both R2 and R3 39-Ohm resistors build up a 90-Ohm differential impedance together with a 5-Ohm output impedance of the Hi-speed channel drivers.

R68 and R69 build up a divider circuit, makes the voltage value reduce from 5V to 3.3V implement plug-in detection (5V level gets lowered to a PIO compatible 3.3V, it implements the detect function through PA0.

Note: PA0 is also shared with ZigBee signal IRQ0.

2.15 ADC

There are 8 multiplexed analog input channels on the 12-bit ADC, as well as the 10-bit ADC. The board optionally connects the two ADC channels to BNC header: one is 12-bit ADC channel 3, the other is 10-bit ADC channel 0.

A potentiometer is also connected to these two channels to implement an easy access to ADC programming and debugging (or implement an analog user control such as display

brightness, volume, etc.).

Note: In the case of default setting, both AD12BAD3 and AD0 connect to the potentiometer, thus, AD12BAD3 and AD0 are actually like being connected together. If these two ports need to work separately, R82 and/or R84 should be removed.

Figure2. ADC Input

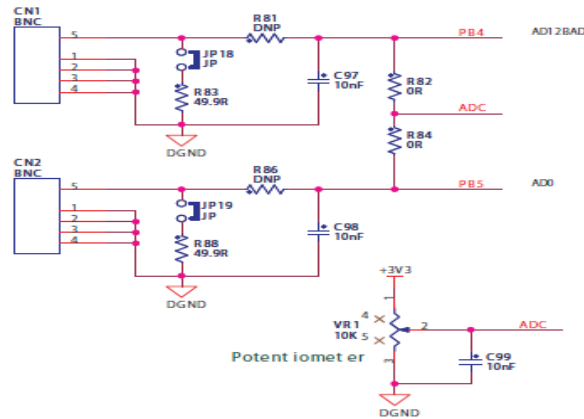

2.16 User Buttons

The board has two user buttons which connect to PIO lines, they are defined as left and right buttons by default.

2.17 Temperature Sensor

A temperature sensor MCP9800 is connected to the SAM3U4E TWI bus. This device also features an open-drain output ALERT pin and outputs an alert signal when the ambient temperature goes beyond the user-programmed temperature limit.

Note that the 0-Ohm resistors R15 and R16 have been implemented to offer a disconnection possibility (freeing these dedicated PIO lines for other custom usage).

2.18 SD Card

The board has an MMC/MMCPlus high-speed 8-bit multimedia interface. This interface is used as a 4/8-bit interface, connected to an 8-bit SD/MMC card slot to do card detection.

2.19 PIO Expansion

The SAM3U4E product features 3 PIO controllers: PIOA, PIOB and PIOC, which multiplex the I/O lines of the peripheral set. Each PIO controller controls up to 32 PIO lines. Expansion ports J13, J14, J15 provide a way for customers to define any PIO channels.

All the expansion port pins are directly connected to the SAM3U4E chip, except PB4 and PB5, which are assigned as AD12BAD3 and AD0 by default on the board. Solder drops have been implemented on the board to avoid signal conflicts from traces routing to expansion ports. If PB4 and PB5 need to be connected to the J14 connector, solder drops SD3 and SD4 should be shorted.

2.20 Hardware Testing

Table4. Routine Introduction of Embest AT91SAM3U Evaluation Board

Experiment Name	Function Description
NVIC	Turn on LED lights according pushing USR-LEFT of USR-RIGHT button.
DMA	DMA transfers data from memory to memory working on Link List Mode.
PDC	In this experiment, PDC module (peripheral DMA controller) obtains serial data from DBGU, stored in the data array, and finally displayed.
USART	Send a message using USART. Display them through PC HyperTerminal. You can also send data or files according PC HyperTerminal. USART can receive them, display the transfer size per second and total transfer size.
PWR	You can control board working in four different power modes (Sleep Mode, Active Mode, Wait Mode, Backup Mode) by pressing different keys according PC HyperTerminal. You can also wakeup it by pushing USR-LEFT button when it working in SLEEP MODE and WAIT MODE, by pushing FWUP button when it working in BACKUP MODE.
GPBR	Write in values to four corresponding backup registers. And then software reset the entire processor and peripherals. At the next restart, display the value of the four back-up registers in HyperTerminal, and compare them with the values written in previously. If there is no difference between them, LED(D2) will blink, else, LED(D3) will blink.
RTT	You can set the pre-divider value, as well as the RTT alarm value in this procedure. It will generate a alarm interrupt as soon as RTT counter reach the value set previously.
RTC	This experiment can detect the RTC time and date, displaying the time the date, setting time and date.
WDT	Let watchdog can generate an interrupt when it's counter value reach zero or there is a error occurred according configuring its mode register. NOTE: don't reset the system. It will generate an interrupt if you haven't reset

	an appropriate value to the corresponding register before the cut-off time.
PWM	This procedure sets up PWM channel 0, channel 1 and channel 2. You can view the output value of channel 0 according PA7 of PBO, view the output value of channel 1 according PA9 or PB2. Positive pulses of Channel 0, Channel 1 and Channel 2 are as the inputs of D2, D3 and D4 (LED) respectively. You can also configure the channel according the serial port.
ADC	This experiment tests ADC0 and ADC12B and show the voltage values from the four-channel ADC pins. You can configure the values of GAIN, Bias Current, Mode, and Sample Offset.
EEFC	To achieve the reading and writing, latches, GPNVM settings, and erase for the two internal FLASH.
NandFlash	Read and write to external NANDFLASH according SMC.
SRAM	Test the external SRAM. Read and write it. If success, D2 lights, else D3 lights.
TIM	This procedure mainly tests TC module of the board. Configure TC working in Waveform Mode. RA=0x1000. It will generate interrupt and turn on LED light when generating Comparing matches.
HSMCI	This procedure tests the HSMCI interface by using a SD card with FAT32 file system. It can format the SD card, write in a bin file, read it and compare its contents with the contents written in previously.
SSC	This sample can play the WAV file, related Information can display in HyperTerminal. The WAV file must be 48KHz, Two-channel stereo, and Previously stored in the SD card. SSC interface connected to WM8731, it can send audio data to WM8731 and decode simply and play. You can hear the music by using a headphone.
SPI	Achieve the communication between SPI interface and touch-screen controller. Touch-screen controller can receive the commands sent from SPI interface and Feedback the corresponding data to SPI.
Touch Screen	The main function of this routine is to obtain the coordinates of the touch-point on the touch screen, and print it in the serial port and LCD screen.

LCD	LCD display routines. It can display characters, text, graphics and so on.
TWI	This procedure test Temp. Sensor according TWI. It can read the values of the sensor internal registers, access to the current configuration, and get the current temperature value.
UDPHS	This is a USB mass-storage test case. There are two DISK sample in this project, one for Extended SRAM addressed from 0x60000000(size: 512KB),one for SD Card inserting on the SD/MMC socket of the board.
USB_CDC	This procedure achieves the test for the USB Communication Device class (CDC) serial communication.
RTX_Traffic	BLINKY test case based on RTX operating system. It simulates the changes of traffic lights at a crossroads.