

### GENERAL DESCRIPTION

OB3398x is a primary side regulation off-line LED lighting power switch which can achieve accurate LED current. It significantly simplifies LED lighting system design by eliminating the secondary side feedback circuitry. Proprietary Constant Voltage (CV) and Constant Current (CC) control is integrated as shown in the figure below.

The LED current (CC control) can be adjusted externally by the resistor  $R_s$  at CS pin.

OB3398x offers comprehensive protection coverage with auto-recovery features including Cycle-by-Cycle current limiting, VDD clamp and UVLO.

OB3398x is offered in SOP7 or DIP8 package.

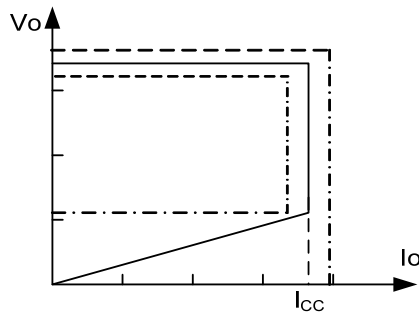

Fig.1. Typical CC/CV Curve

### FEATURES

- High Precise Constant Current Regulation at Universal AC input
- Primary-side Sensing and Regulation Without TL431 and Opto-coupler
- HV MOSFET integrated
- Floating PSR control scheme with two transformer windings
- Adjustable Constant Current and Output Power Setting
- Built-in Primary winding inductance compensation
- Built-in Leading Edge Blanking (LEB)
- Cycle-by-Cycle Current Limiting
- VDD Under Voltage Lockout with Hysteresis (UVLO)
- Latched over temperature protection (OTP)
- VDD Clamp

### APPLICATIONS

Low Power AC/DC offline SMPS for

- LED applications

### TYPICAL APPLICATION

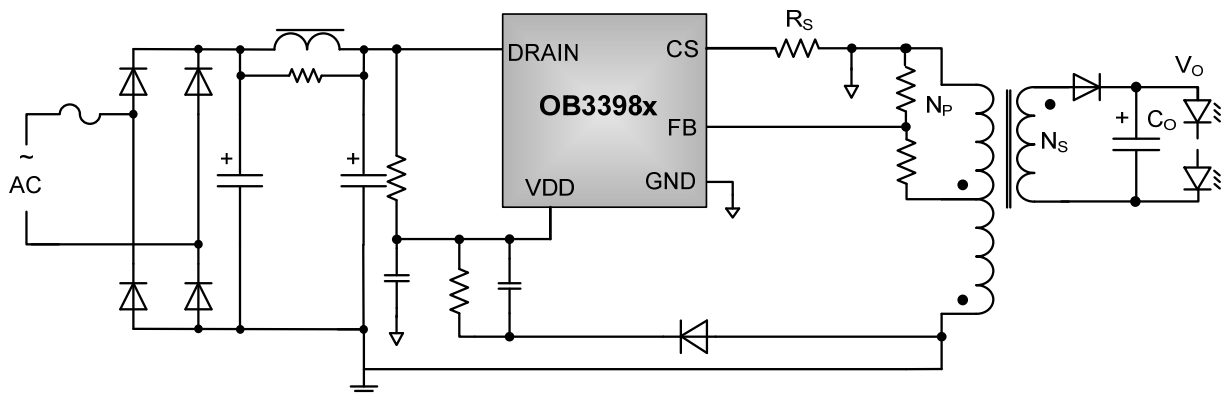

### GENERAL INFORMATION

#### Pin Configuration

The pin map is shown as below for DIP8.

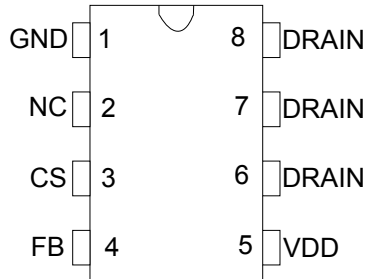

The pin map is shown as below for SOP7.

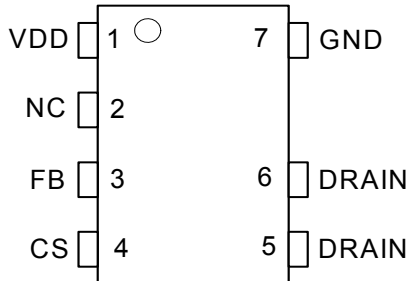

#### Absolute Maximum Ratings

Parameter	Value
Drain Voltage	-0.3 to BV <sub>dss</sub>
VDD Voltage	-0.3 to V <sub>DD clamp</sub>
CS Input Voltage	-0.3 to 7V
FB Input Voltage	-0.3 to 7V
Min/Max Operating Junction Temperature T <sub>J</sub>	-40 to 150 °C
Operating Temperature T <sub>A</sub> Ambient	-40 to 85 °C
Min/Max Storage Temperature T <sub>stg</sub>	-55 to 150 °C
Lead Temperature (Soldering, 10secs)	260 °C

**Note:** Stresses beyond those listed under “absolute maximum ratings” may cause permanent damage to the device. These are stress ratings only, functional operation of the device at these or any other conditions beyond those indicated under “recommended operating conditions” is not implied. Exposure to absolute maximum-rated conditions for extended periods may affect device reliability.

#### Recommended Operating Condition

Symbol	Parameter	Range
VDD	VDD Supply Voltage	12 to 25 V

#### Ordering Information

Part Number	Description
OB3398NJP	SOP7, Halogen-free, Tube
OB3398NJPA	SOP7, Halogen-free, T&R
OB3398PJP	SOP7, Halogen-free, Tube
OB3398PJPA	SOP7, Halogen-free, T&R
OB3398TAP	DIP8, Halogen-free, Tube
OB3398PAP	DIP8, Halogen-free, Tube
OB3398NAP	DIP8, Halogen-free, Tube
OB3398RAP	DIP8, Halogen-free, Tube
OB3398VAP-H	DIP8, Halogen-free, Tube
OB3398UAP-H	DIP8, Halogen-free, Tube
OB3398TJP-H	SOP7, Halogen-free, Tube
OB3398TJPA-H	SOP7, Halogen-free, T&R
OB3398RJP	SOP7, Halogen-free, Tube
OB3398RJPA	SOP7, Halogen-free, T&R

#### Output Power Table

Product	90Vac~264Vac Input	220Vac±20% Input
OB3398NJP	8W	13.5W
OB3398PJP	12.8W	16.9W
OB3398TJP-H	16.3W	21W
OB3398NAP	11W	18.5W
OB3398RAP	20W	28.5W
OB3398PAP	18.5W	26W
OB3398TAP	22W	33W
OB3398VAP-H	32W	44W
OB3398UAP-H	24.4W	38W
OB3398RJP	13W	18.2W

**Note:** Maximum practical continuous power in an open frame design with sufficient drain pattern as a heat sink, at 50°C ambient and 60°C temperature rise. Higher output power is possible with extra added heat sink, air circulation and decrease output current to reduce thermal resistance

#### Package Dissipation Rating

Package	RθJA (°C/W)
SOP7	95
DIP8	75

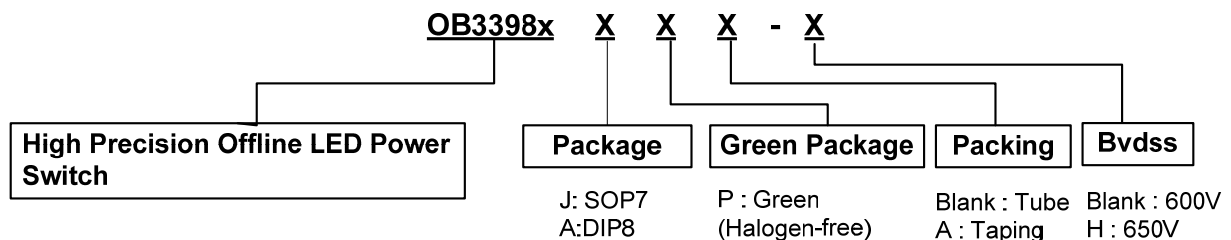

### Marking Information



Y:Year Code  
WW:Week Code(01-52)  
ZZZ:Lot Code  
A:DIP8 Package  
P:Green Package(Halogen-free)  
S:Internal Code(Optional)



Y:Year Code  
WW:Week Code(01-52)  
ZZZ:Lot Code  
A:DIP8 Package  
P:Green Package(Halogen-free)  
S:Internal Code(Optional)



Y:Year Code  
WW:Week Code(01-52)  
ZZZ:Lot Code  
A:DIP8 Package  
P:Green Package(Halogen-free)  
S:Internal Code(Optional)



Y:Year Code  
WW:Week Code(01-52)  
ZZZ:Lot Code  
A:DIP8 Package  
P:Green Package(Halogen-free)  
S:Internal Code(Optional)

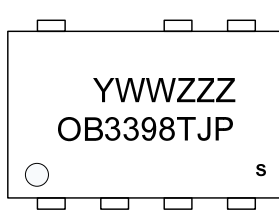

Y:Year Code  
WW:Week Code(01-52)  
ZZZ:Lot Code  
J:SOP7 Package  
P:Green Package(Halogen-free)  
S:Internal Code(Optional)

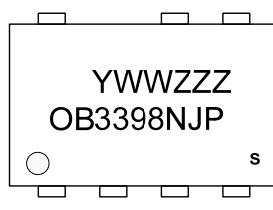

Y:Year Code  
WW:Week Code(01-52)  
ZZZ:Lot Code  
J:SOP7 Package  
P:Green Package(Halogen-free)  
S:Internal Code(Optional)



Y:Year Code  
WW:Week Code(01-52)  
ZZZ:Lot Code  
J:SOP7 Package  
P:Green Package(Halogen-free)  
S:Internal Code(Optional)



Y:Year Code  
WW:Week Code(01-52)  
ZZZ:Lot Code  
A:DIP8 Package  
P:Green Package(Halogen-free)  
S:Internal Code(Optional)



Y:Year Code  
WW:Week Code(01-52)  
ZZZ:Lot Code  
A:DIP8 Package  
P:Green Package(Halogen-free)  
S:Internal Code(Optional)



Y:Year Code  
WW:Week Code(01-52)  
ZZZ:Lot Code  
J:SOP7 Package  
P:Green Package(Halogen-free)  
S:Internal Code(Optional)

**TERMINAL ASSIGNMENTS for OB3398TAP/ PAP/NAP/VAP/UAP/RAP**

Pin Num	Pin Name	I/O	Description
1	GND	P	Ground
2	NC		No connect
3	CS	I	Current sense input.
4	FB	I	Connected to resistor divider from primary winding or auxiliary winding to reflect output voltage.
5	VDD	P	Power Supply
6,7,8	Drain	O	Drain of internal power MOSFET

**TERMINAL ASSIGNMENTS for OB3398PJP/NJP/RJP**

Pin Num	Pin Name	I/O	Description
1	VDD	P	Power Supply
2	NC		No connect
3	FB	I	Connected to resistor divider from primary winding or auxiliary winding to reflect output voltage.
4	CS	I	Current sense input.
5,6	Drain	O	Drain of internal power MOSFET
7	GND	P	Ground

**BLOCK DIAGRAM**

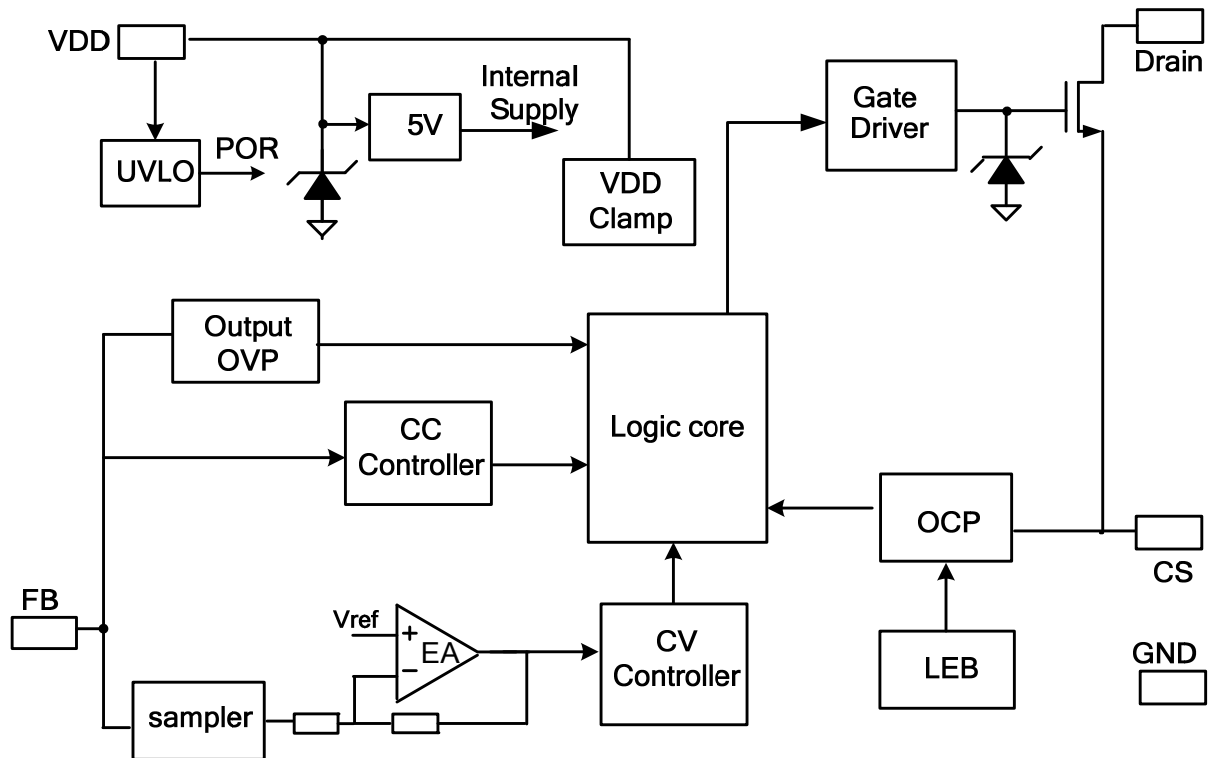

**ELECTRICAL CHARACTERISTICS**

(TA = 25°C, VDD=16V, if not otherwise noted)

Symbol	Parameter	Test Conditions	Min	Typ.	Max	Unit
<b>Supply Voltage (VDD) Section</b>						
I <sub>startup</sub>	Startup Current	VDD=UVLO_OFF-1V		4	20	uA
I <sub>DD op</sub>	Operation Current	Operation supply current FB=1V, CS=0V, VDD= 20V		0.45	1	mA
UVLO(ON)	VDD Under Voltage Lockout Enter	VDD falling	7.3	8.3	9.3	V
UVLO(OFF)	VDD Under Voltage Lockout Exit	VDD rising	15.5	16.5	17.5	V
V <sub>DD_clamp</sub>	Maximum VDD operation voltage	I <sub>DD</sub> =20mA		25		V
<b>Current Sense Input Section</b>						
TLEB	LEB time			500		ns
V <sub>th_oc</sub>	Over current threshold		492	500	508	mV
T <sub>d_oc</sub>	OCP Propagation delay			100		ns
<b>Frequency Section</b>						
Freq_Max <sup>Note</sup>	IC Maximum frequency		103			KHz
T <sub>off_min</sub>	Minimum Toff			4.0		us
F <sub>min</sub>	Minimum frequency			103		Hz
<b>Error Amplifier section</b>						
V <sub>ref_EA</sub>	Reference voltage for EA		1.14	1.2	1.26	V
Gain	DC gain of EA			40		
V <sub>th_OVP</sub>	Load OVP threshold voltage			1.4		V
<b>On chip Over temperature Section</b>						
T <sub>otp</sub>	latched over temperature protection trigger point			155		°C

Product	Parameter	BV <sub>dss</sub> (V) MOSFET Drain-Source Breakdown Voltage		
		Min	Typ.	Max
OB3398TAP		600		
OB3398PAP		600		
OB3398NAP		600		
OB3398RAP		600		
OB3398PJP		600		
OB3398NJP		600		
OB3398RJP		600		
OB3398VAP-H		650		
OB3398TJP-H		650		
OB3398UAP-H		650		

**Note:**

Freq\_Max indicates IC internal maximum clock frequency. In system application, the maximum operation frequency of 103KHz nominal occurs at maximum output power or the transition point from CV to CC.

**CHARACTERIZATION PLOTS**

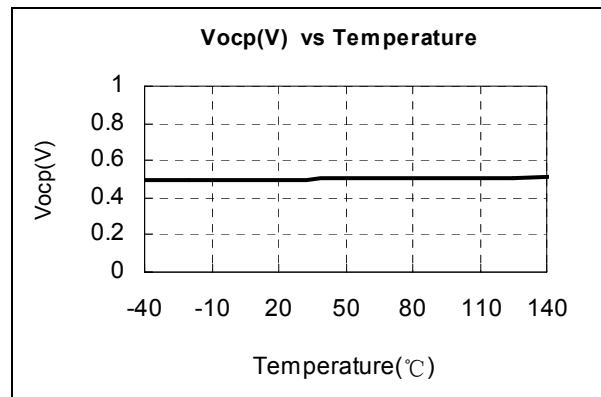
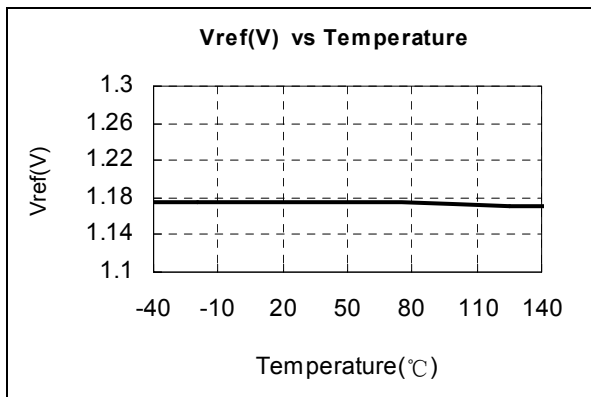
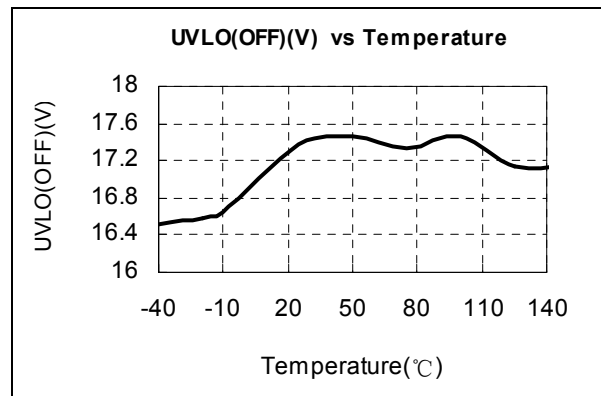
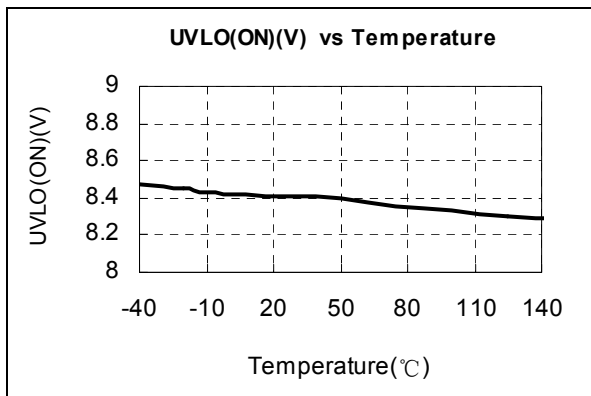
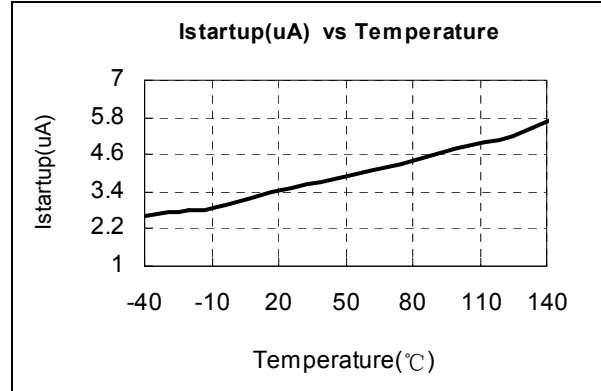
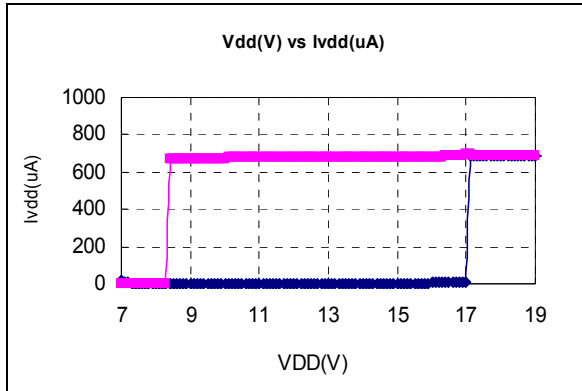

## OPERATION DESCRIPTION

OB3398x is a cost effective PWM power switch optimized for off-line LED lighting applications. Based on floating flyback converter topology working in DCM mode, it operates in primary side sensing and regulation, thus opto-coupler and TL431 are not required. Proprietary built-in CC control can achieve high precision LED current meeting LED lighting application requirements.

### Startup Current and Start up Control

Startup current of OB3398x is designed to be very low so that VDD could be charged up above UVLO threshold and starts up quickly. A large value startup resistor can therefore be used to minimize the power loss in application.

### Operating Current

The Operating current of OB3398x is as low as 0.45mA(Typ.). Typical good efficiency is achieved with the low operating current together with 'Multi-mode' control features.

### Principle of CC Operation

To support OB3398x proprietary CC control, system needs to be designed in DCM mode for flyback system (Refer to Typical Application Diagram on page1). The LED output current  $I_{LED}$  is given by:

$$I_{LED} = \frac{1}{2} L_p \cdot F_{SW} \cdot I_{PK}^2 \cdot \eta / V_o \quad (1)$$

Where  $L_p$  indicates the inductance of primary winding,  $I_{pk}$  is the peak current of primary winding.

Refer to the equation 1, the change of the primary winding inductance results in the change of the constant output current. To compensate the change from variations of primary winding inductance, the switching frequency is locked by an internal loop such that the switching frequency is

$$F_{SW} = \frac{1}{2T_{Demag}} \quad (2)$$

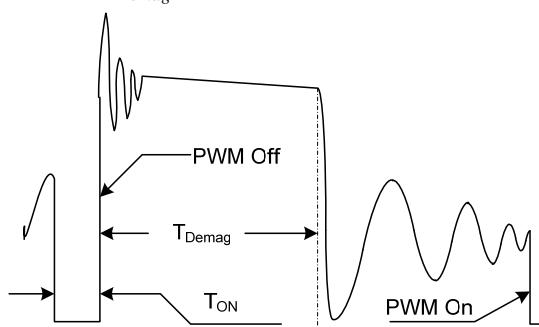

Figure.1 Primary voltage waveform

Since  $T_{Demag}$  is inversely proportional to the inductance, as a result, the product  $L_p$  and  $f_{sw}$  is constant, thus output current will not change as primary winding inductance changes. Up to  $\pm 7\%$  variation of the primary winding inductance can be compensated.

The output LED current is

$$I_{LED} = \frac{1}{4} \cdot N \cdot \frac{V_{th_{oc}}}{R_s} \quad (3)$$

Where N is the ratio of transformer between primary winding and secondary winding.

### Adjustable CC point and Output Power

In OB3398x, the CC point and maximum output power can be externally adjusted by external current sense resistor  $R_s$  at CS pin as illustrated in Typical Application Diagram. The output power is adjusted through CC point change. The larger  $R_s$ , the smaller CC point is, and the smaller output power becomes, and vice versa as shown in Fig.2.

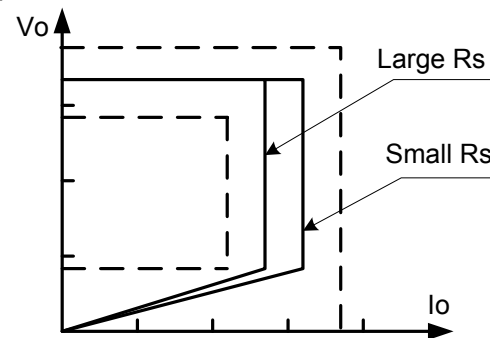

Figure.2 Adjustable output power by changing  $R_s$

### Operation switching frequency

The switching frequency of OB3398x is adaptively controlled according to the load conditions and the operation modes. No external frequency setting components are required. The operation switching frequency at maximum output power is set to 103K Hz internally.

For flyback operating in DCM, The maximum output power is given by

$$P_{Omax} = \frac{1}{2} \eta L_p F_{SW} I_{pk}^2 \quad (4)$$

Where  $L_p$  indicate the inductance of primary winding and  $I_{pk}$  is the peak current of primary winding.

The principle of CC operation sets the product  $L_p$  and  $f_{sw}$  to be a constant, thus the maximum output power and constant current in CC mode will not change as primary winding inductance changes. Up to  $\pm 7\%$  variation of the primary winding inductance can be compensated.



**CV / OVP Mode**

When LED string is open, an output voltage condition is monitored independently by the voltage at FB pin. During normal operation, the voltage at FB pin is regulated at 1.2V (typ.), with dummy load over P<sub>min</sub>.

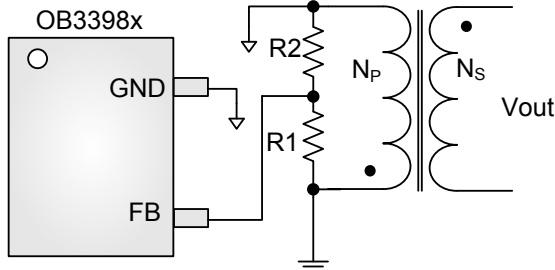

Figure.3 FB Section Circuit

$$V_{OUT} = \frac{N_s}{N_p} \times \frac{R1 + R2}{R2} \times V_{ref\_CV}$$

R1 —Resistor connected between the FB pin and the input capacitor GND, the value suggested is 330Kohms~1Mohms

R2 —Resistor connected between the FB pin and the GND pin of IC, the value suggested is 5Kohms~15Kohms

$$P_{min} = \frac{1}{2} \times \left( \frac{V_{th\_oc}}{R_{CS}} \right)^2 F_{min} L_{primary}$$

V<sub>th\_oc</sub> — Over current protection threshold voltage

F<sub>min</sub> — Minimum switching frequency, which is 103Hz (typ.)

If the dummy load is less than P<sub>min</sub>, the output voltage rises up. If the voltage at FB pin exceeds a threshold of approximately 1.4V (typical), the over-voltage protection function is activated and the switching is turned off immediately.

$$V_{OVP} = \frac{N_s}{N_p} \times \frac{R1 + R2}{R2} \times V_{vth\_OVP}$$

**CC Line Regulation**

Adjust the R1 for better CC line regulation, while driving different type MOSFET. The larger MOSFET, the smaller R1 needed. R1 allow the change from 330K to 1M ohms to cover all the applications. If the resistance is too large, it causes the interference due to the floating ground, too small resistance results the efficiency decreased at HV AC line.

**Current Sensing and Leading Edge Blanking**

Cycle-by-Cycle current limiting is offered in OB3398x. The switch current is detected by a sense resistor into the CS pin. An internal leading edge blanking circuit chops off the sensed voltage spike at initial power MOSFET. The PWM duty cycle is determined by the current sense input voltage and the EA output voltage.

**Protection Control**

Good power supply system reliability is achieved with its rich protection features including Cycle-by-Cycle current limiting (OCP), VDD clamp, on-chip OTP, and Under Voltage Lockout on VDD (UVLO).

Over temperature protection is offered in OB3398x. When temperature of the device rises over 150°C (typical), the switching frequency will decrease to half. And the state will be kept until the device restarts.

VDD is supplied by transformer primary winding output. The output of OB3398x is shut down when VDD drops below UVLO (ON) limit and the power converter enters power on start-up sequence thereafter.

**PACKAGE MECHANICAL DATA**

**DIP8 PACKAGE OUTLINE DIMENSIONS**

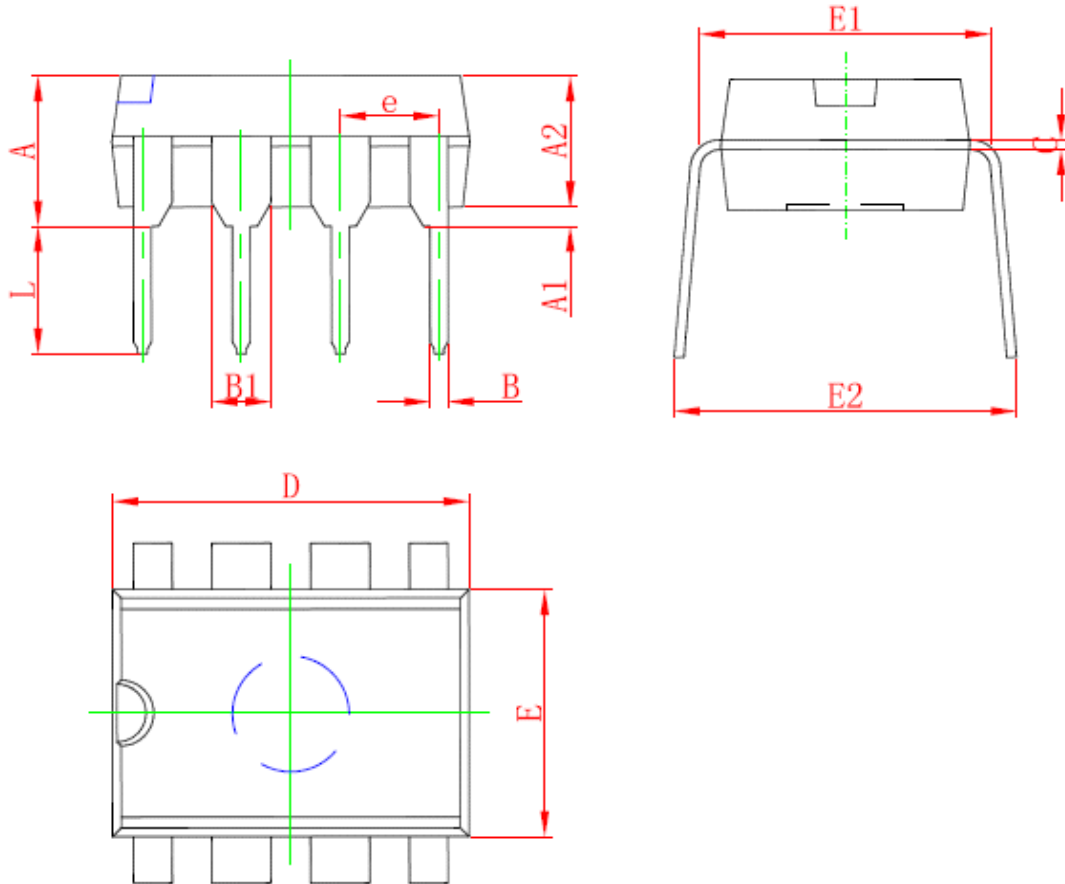

Symbol	Dimensions In Millimeters		Dimensions In Inches	
	Min	Max	Min	Max
A	3.710	5.334	0.146	0.210
A1	0.381		0.015	
A2	2.921	4.953	0.115	0.195
B	0.350	0.650	0.014	0.026
B1	1.524 (BSC)		0.06 (BSC)	
C	0.200	0.360	0.008	0.014
D	9.000	10.160	0.354	0.400
E	6.096	7.112	0.240	0.280
E1	7.320	8.255	0.288	0.325
e	2.540 (BSC)		0.1 (BSC)	
L	2.921	3.810	0.115	0.150
E2	7.620	10.920	0.300	0.430

**SOP7 PACKAGE OUTLINE DIMENSIONS**

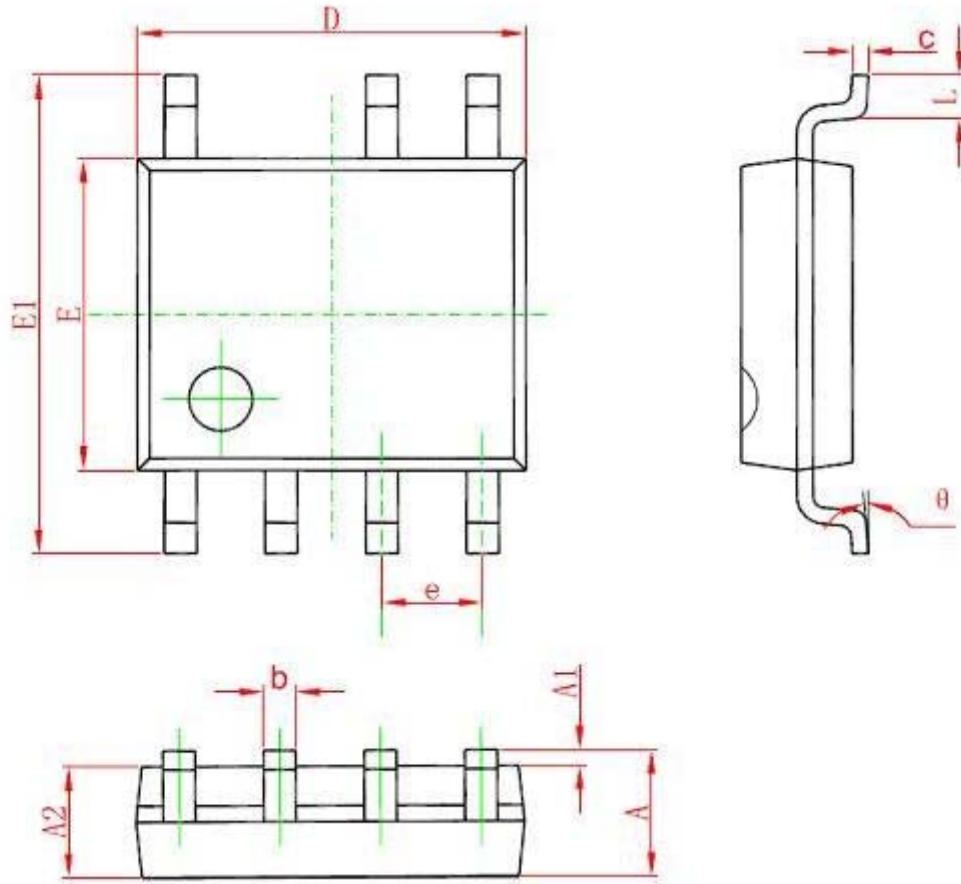

Symbol	Dimensions In Millimeters		Dimensions In Inches	
	Min	Max	Min	Max
A	1.350	1.750	0.053	0.069
A1	0.050	0.250	0.002	0.010
A2	1.250	1.650	0.049	0.065
b	0.310	0.510	0.012	0.020
c	0.100	0.250	0.004	0.010
D	4.700	5.150	0.185	0.203
E	3.800	4.000	0.150	0.157
E1	5.800	6.200	0.228	0.244
e	1.270 (BSC)		0.050 (BSC)	
L	0.400	1.270	0.016	0.050
$\theta$	0°	8°	0°	8°

## **IMPORTANT NOTICE**

### **RIGHT TO MAKE CHANGES**

On-Bright Electronics Corp. reserves the right to make corrections, modifications, enhancements, improvements and other changes to its products and services at any time and to discontinue any product or service without notice. Customers should obtain the latest relevant information before placing orders and should verify that such information is current and complete.

### **WARRANTY INFORMATION**

On-Bright Electronics Corp. warrants performance of its hardware products to the specifications applicable at the time of sale in accordance with its standard warranty. Testing and other quality control techniques are used to the extent it deems necessary to support this warranty. Except where mandated by government requirements, testing of all parameters of each product is not necessarily performed.

On-Bright Electronics Corp. assumes no liability for application assistance or customer product design. Customers are responsible for their products and applications using On-Bright's components, data sheet and application notes. To minimize the risks associated with customer products and applications, customers should provide adequate design and operating safeguards.

### **LIFE SUPPORT**

On-Bright Electronics Corp.'s products are not designed to be used as components in devices intended to support or sustain human life. On-bright Electronics Corp. will not be held liable for any damages or claims resulting from the use of its products in medical applications.

### **MILITARY**

On-Bright Electronics Corp.'s products are not designed for use in military applications. On-Bright Electronics Corp. will not be held liable for any damages or claims resulting from the use of its products in military applications.