

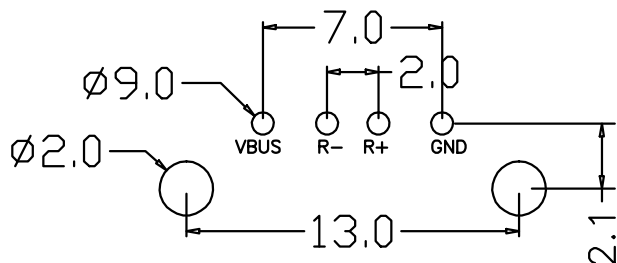

REV.	ECN NO OR DESCRIPTION	REVISED	DATE

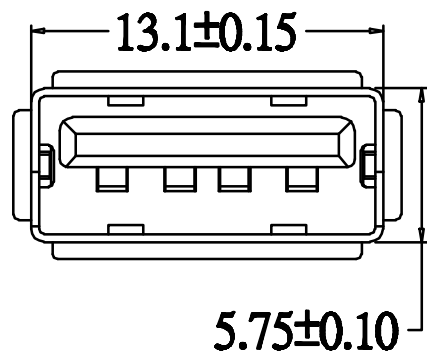
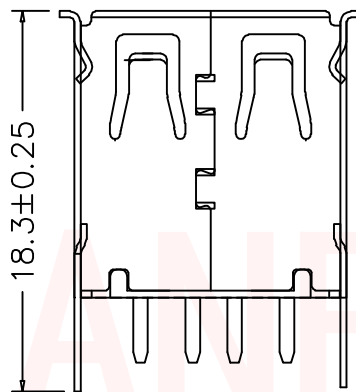
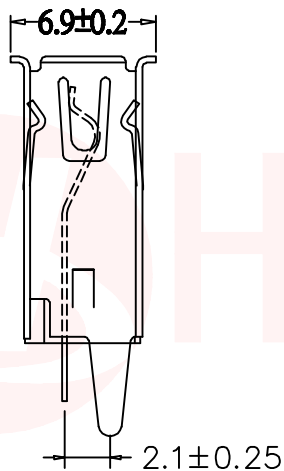
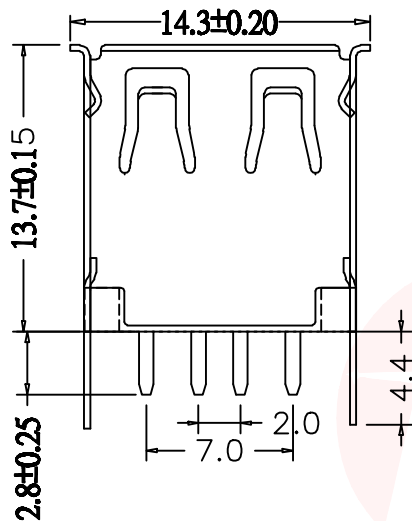

规格说明: Specifications:

电气特性: Electrical:

1. 额定电流: Current Rating
1.5A/contact terminal
2. 额定电压: Voltage Rating
30V DC
3. 接触电阻: Contact Resistance
30 milliohms MAX
4. 耐压: Dielectric Withstanding Voltage:
500 V AC AT Sea Level
5. 绝缘电阻: Insulation Resistance:
1000MEGA ohms MIN

物理性能: Mechanical:

1. 插拔力: Connector Mate and Unmate Force
Mate force: 3.57kgf (MAX)
Unmate force: 1.02kgf (MIN)

原材料: Material:

1. 塑胶: Housing:
High Temperature Thermoplastics,
2. 端子: Contact: Copper Alloy C2680
3. 外壳: Shell: Copper Alloy C2680/SPCC

电镀: Finish:

1. 端子: Contact: Plated Gold in Mating Area
Tin On Solder Tails

端子四周镀50U”(MIN)锡,镀金1U”

2. 外壳: Shell:
四周镀80U”(MIN)锡

UNLESS OTHERWISE SPECIFIED TOLERANCES

DECIMALS:	ANGLES:
X : ±0.30	X : ±2°
X.X : ±0.20	X.X : ±1°
X.XX : ±0.10	



东莞市汉博电子科技有限公司
DONGGUAN HANBO TECHNOLOGY CO., LTD

TITLE	USB 2.0 AF 直插式13.7 卷边 铁壳			
DWN	xiiong	PART NO.	USB-U255ZH137-BJS	
CHKD	lee	SCALE: 1:1	UNIT: mm	
APVD	wang	SIZE: A4	SHEET: 1 OF 1	REV: A4

CUSTOMER COPY