

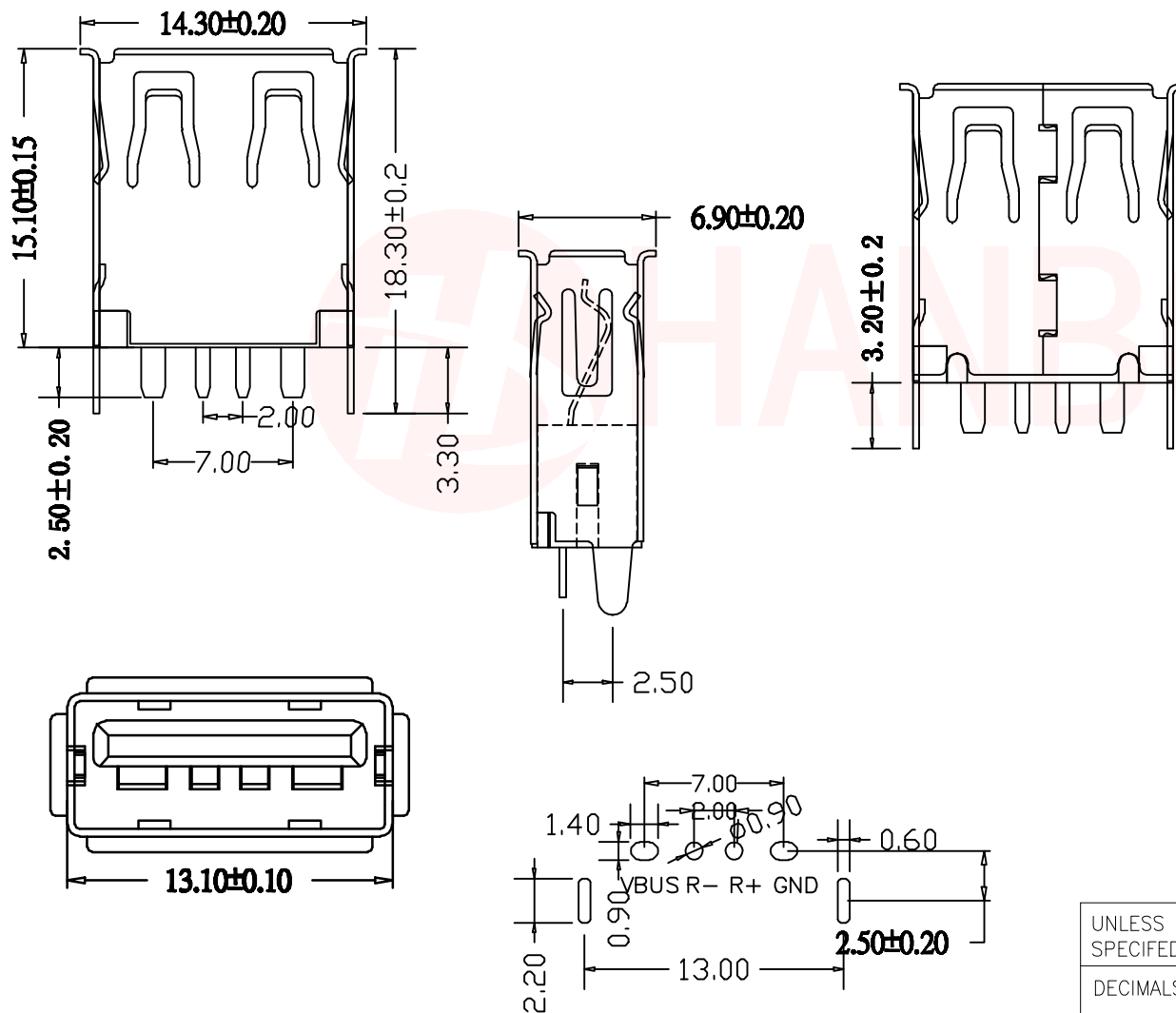

REV.	ECN NO OR DESCRIPTION	REVISED	DATE



规格说明: Specifications:

电气特性: Electrical:

1. 额定电流: Current Rating
3A/contact terminal
2. 额定电压: Voltage Rating
30V DC
3. 接触电阻: Contact Resistance
30 milliohms MAX
4. 耐压: Dielectric Withstanding Voltage:
500 V AC AT Sea Level
5. 绝缘电阻: Insulation Resistance:
1000MEGA ohms MIN

物理性能: Mechanical:

1. 插拔力: Connector Mate and Unmate Force
Mate force: 3.57kgf(MAX)
Unmate force: 1.02kgf(MIN)
2. 端子保持力: Terminal Retention
1.0kgf(MIN)

原材料: Material:

1. 塑胶: Housing:
Hing Temperature Thermoplastics,
2. 端子: Contact: Copper Alloy C2680
3. 外壳: Shell: Copper Alloy C2680/SPCC

电镀: Finish:

1. 端子: Contact: Plated Gold in Mating Area
Tin On Solder Talls

端子四周镀30-50U”(MIN)锡, 镀金区域镀金1U”

2. 外壳: Shell:
四周镀(MIN)镍

UNLESS OTHERWISE SPECIFIED TOLERANCES		东莞市汉博电子科技有限公司 DONGGUAN HANBO TECHNOLOGY CO., LTD		
DECIMALS:	ANGLES:	TITLE	USB 2.0 AF直插15.0卷边直脚大电流	
X : ±0.30	X : ±2°	DWN	xiiong	PART NO. USB-UD250-BJS
X.X : ±0.20	X.X : ±1°	CHKD	lee	SCALE: 1:1 UNIT: mm
X.XX : ±0.10		APVD	wang	SIZE: A4 SHEET: 1OF 1 REV: A4
CUSTOMER COPY				