

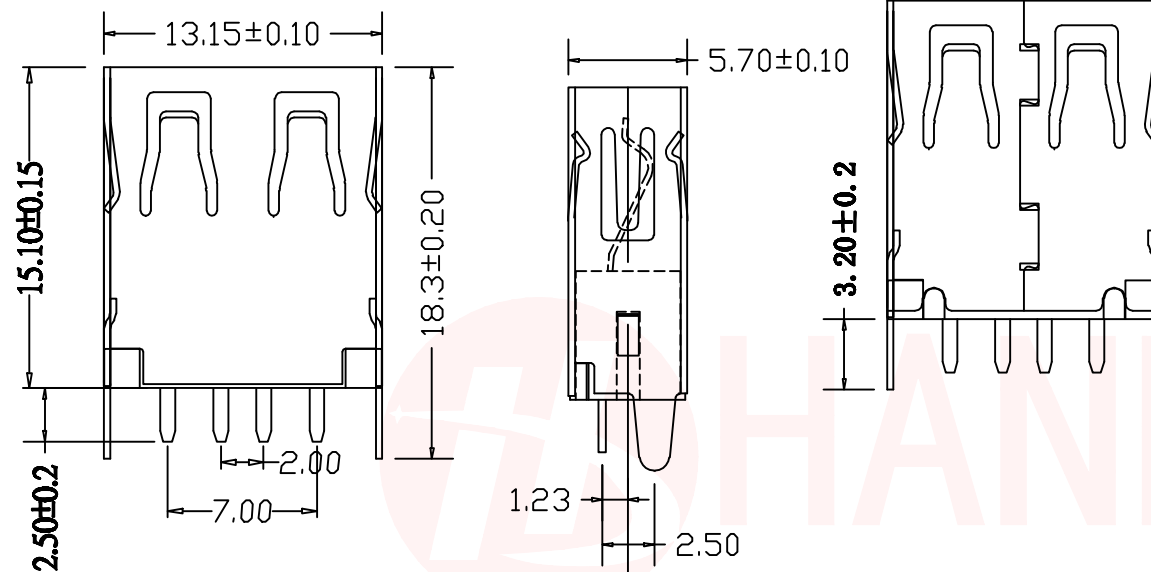

REV.	ECN NO OR DESCRIPTION	REVISED	DATE



规格说明: Specifications:

电气特性: Electrical:

1. 额定电流: Current Rating  
1.5A/contact terminal
2. 额定电压: Voltage Rating  
30V DC
3. 接触阻抗: Contact Resistance  
30 milliohms MAX
4. 耐压: Dielectric Withstanding Voltage:  
500 V AC AT Sea Level
5. 绝缘阻抗: Insulation Resistance:  
1000MEGA ohms MIN

物理性能: Mechanical:

1. 插拔力: Connector Mate and Unmate Force  
Mate force: 3.57kgf(MAX)  
Unmate force: 1.02kgf(MIN)
2. 端子保持力: Terminal Retention  
1.0kgf(MIN)

原材料: Material:

1. 塑胶: Housing:  
High Temperature Thermoplastics,
2. 端子: Contact: Copper Alloy C2680
3. 外壳: Shell: Copper Alloy C2680/SPCC

电镀: Finish:

1. 端子: Contact: Plated Gold in Mating Area  
Tin On Solder Tails

端子四周镀30-50U”(MIN)锡, 镀金区域镀金1U”

2. 外壳: Shell:  
四周镀 MIN 镍

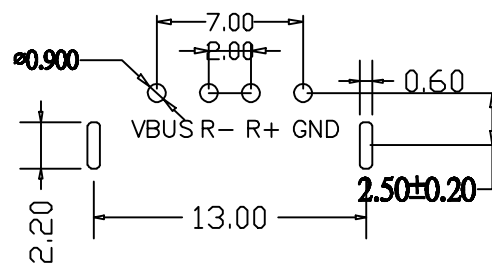

UNLESS OTHERWISE SPECIFIED TOLERANCES		东莞市汉博电子科技有限公司 DONGGUAN HANBO TECHNOLOGY CO., LTD			
DECIMALS:	ANGLES:	TITLE	USB 2.0 AF直插15.0直边 铁壳		
X : ±0.30	X : ±2°	DWN	xiong	PART NO. USB-U255ZH150-BWS	
X.X : ±0.20	X.X : ±1°	CHKD	lee	SCALE: 1:1	UNIT: mm
X.XX : ±0.10		APVD	wang	SIZE: A4	SHEET: 10F 1
CUSTOMER COPY					