

P-Channel 30-V (D-S) MOSFET

■ FEATURES

- Low $R_{DS(on)}$ Provides Higher Efficiency and Extends Battery Life
- High power and current handling capability
- Miniature SOP-8 Surface Mount Package Saves Board Space

■ Product Summary

MOSFET		
$V_{DS}(V)$	$R_{DS(on)} (m\Omega)$	$I_D (A)$
-30	60 @ $V_{GS} = -10V$	-4.9
	90 @ $V_{GS} = -4.5V$	-3.7

■ Description

These miniature surface mount MOSFETs utilize a high cell density trench process to provide low $R_{DS(on)}$ and to ensure minimal power loss and heat dissipation. Typical applications are DC-DC converters and power management in portable and battery-powered products such as computers, printers, and PCMCIA cards, cellular and cordless telephones.

■ SOP-8

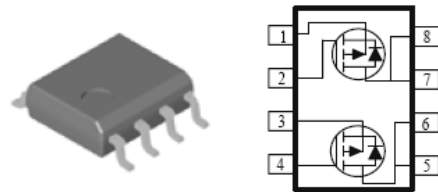

Maximum Ratings (TA = 25 °C UNLESS OTHERWISE NOTED)

Symbol	Parameter	Maximum	Unit	
V_{DS}	Drain-Source Voltage	-30	V	
V_{GS}	Gate-Source Voltage	±20		
I_D	Continuous Drain Current ^a	$T_A=25^{\circ}C$	±4.9	A
		$T_A=70^{\circ}C$	±4.2	
I_{DM}	Pulsed Drain Current ^b	±30		
I_S	Continuous Source Current (Diode Conduction) ^a	-1.6	A	
P_D	Power Dissipation ^a	$T_A=25^{\circ}C$	2.1	W
		$T_A=70^{\circ}C$	1.3	
T_J, T_{stg}	Operation Junction and Storage Temperature Range	-55 to 150	°C	

Thermal Resistance Ratings

Symbol	Parameter	Maximum	Unit
$R_{\theta JA}$	Maximum Junction-to-Ambient ^a	60	°C/W
$R_{\theta JC}$	Maximum Junction-to-Case ^a	40	°C/W

Notes:

- (a) Surface Mounted on 1" x 1" FR4 Board.
 (b) Pulse width limited by maximum junction temperature

Electrical Characteristics

SPECIFICATIONS (TA = 25°C UNLESS OTHERWISE NOTED)						
Parameter	Symbol	Test Condition	Limits			Unit
			Min	Typ	Max	
Static						
Gate-Threshold Voltage	$V_{GS(th)}$	$V_{DS} = V_{GS}, I_D = -250 \mu A$	-1	-1.5	-3	V
Gate-Body Leakage	I_{GSS}	$V_{DS} = 0 V, V_{GS} = \pm 20V$			± 100	nA
Zero Gate Voltage Drain Current	I_{DSS}	$V_{DS} = -24 V, V_{GS} = 0 V$			-1	uA
		$V_{DS} = -24 V, V_{GS} = 0 V, T_J = 55^\circ C$			-5	
On-State Drain Current ^a	$I_{D(on)}$	$V_{DS} = -5V, V_{GS} = -10V$	-30			A
Drain-Source On-Resistance ^a	$R_{DS(on)}$	$V_{GS} = -10 V, I_D = -4.9 A$		50	60	mΩ
		$V_{GS} = -4.5 V, I_D = -3.7 A$		75	90	
Forward Transconductance ^a	g_{fs}	$V_{DS} = -15V, I_D = -4.9A$		10		S
Diode Forward Voltage	V_{SD}	$I_S = -1.9 A, V_{GS} = 0 V$			-1.3	V
Dynamic ^b						
Total Gate Charge	Q_g	$V_{DS} = -15V, V_{GS} = -10V, I_D = -5.2A$		28		nC
Gate-Source Charge	Q_{gs}			3		
Gate-Drain Charge	Q_{gd}			7		
Input Capacitance	C_{iss}	$V_{DS} = -15V, V_{GS} = 0V, f = 1MHz$		745		pF
Output Capacitance	C_{oss}			440		
Reverse Transfer Capacitance	C_{rss}			120		
Switching						
Turn-On Delay Time	$t_{d(on)}$	$V_{DD} = -15V, R_L = 15\Omega, I_D = -1A, V_{GEN} = -10V, R_G = 6\Omega$		9		nS
Turn-On Rise Time	t_r			15		
Turn-Off Delay Time	$t_{d(off)}$			75		
Turn-Off Fall Time	t_f			40		

Notes:

- (a) Pulse test: pulse width $\leq 300\mu s$, duty cycle $\leq 2\%$
(b) Guaranteed by design; not subject to production testing

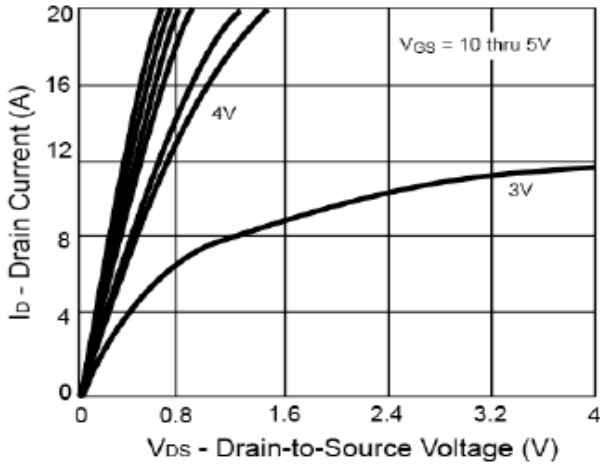
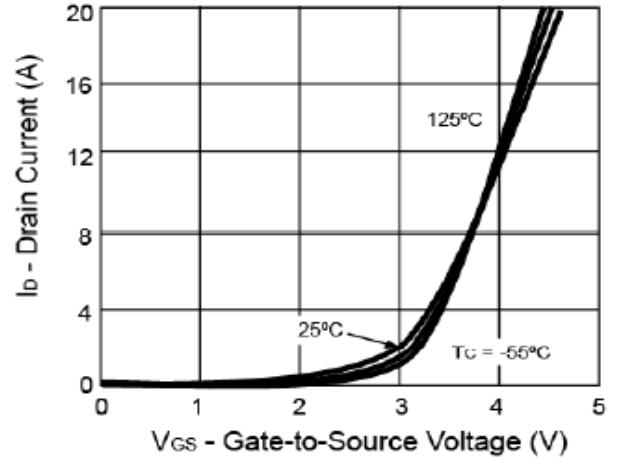
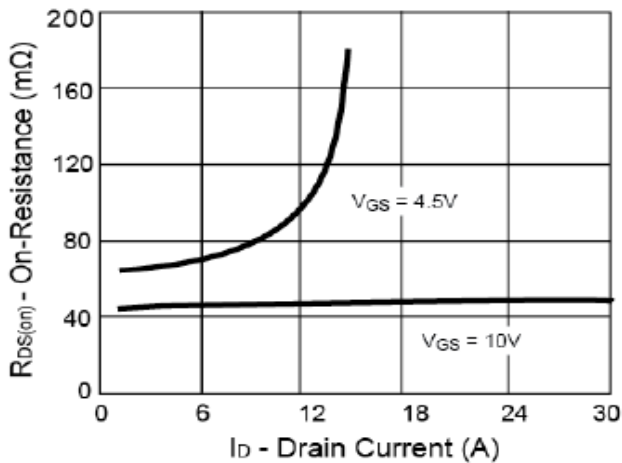
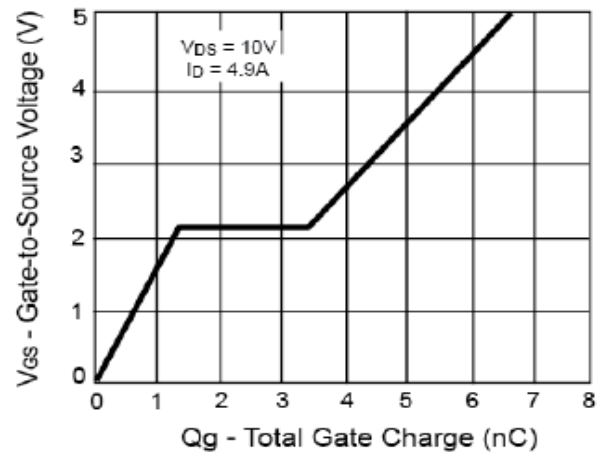
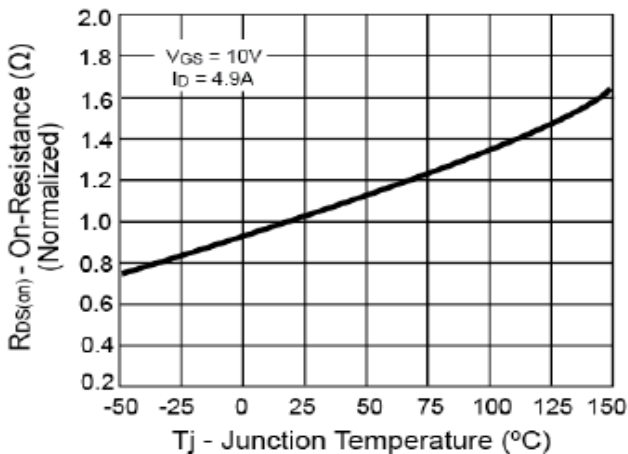
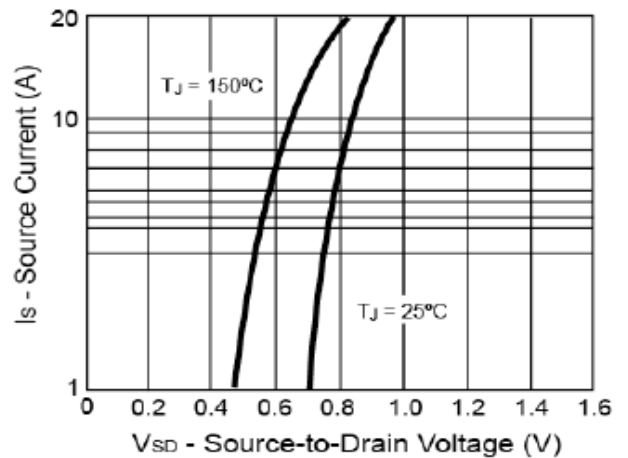
Typical Electrical Characteristics
Output Characteristics

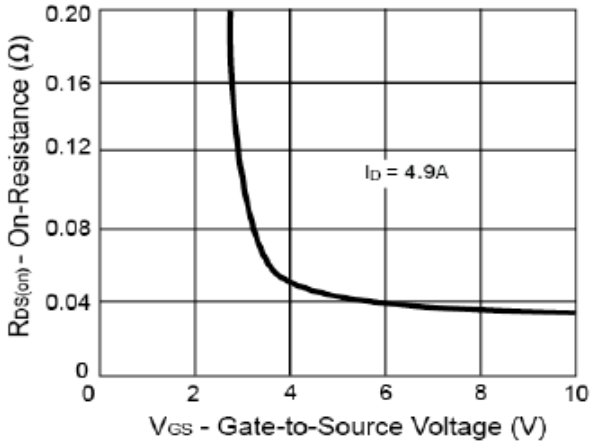
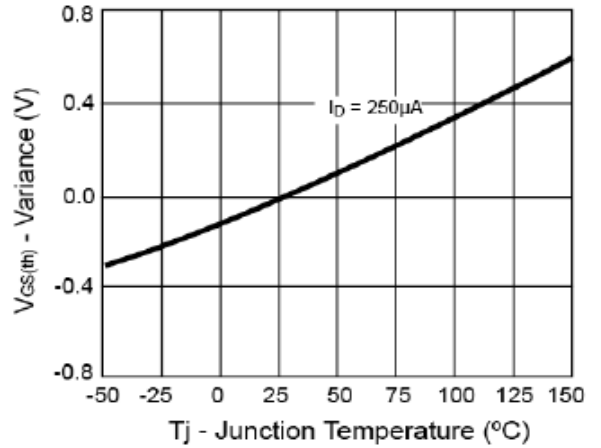
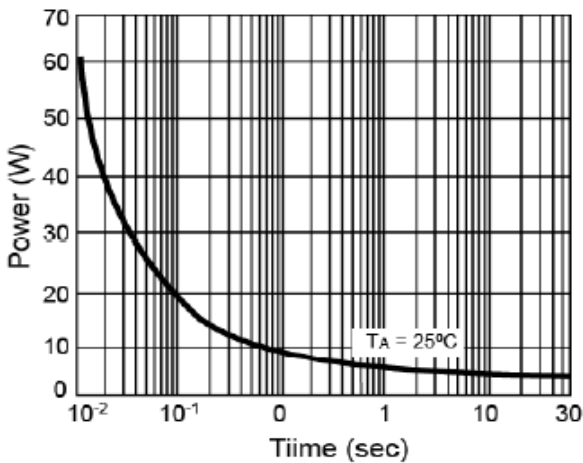
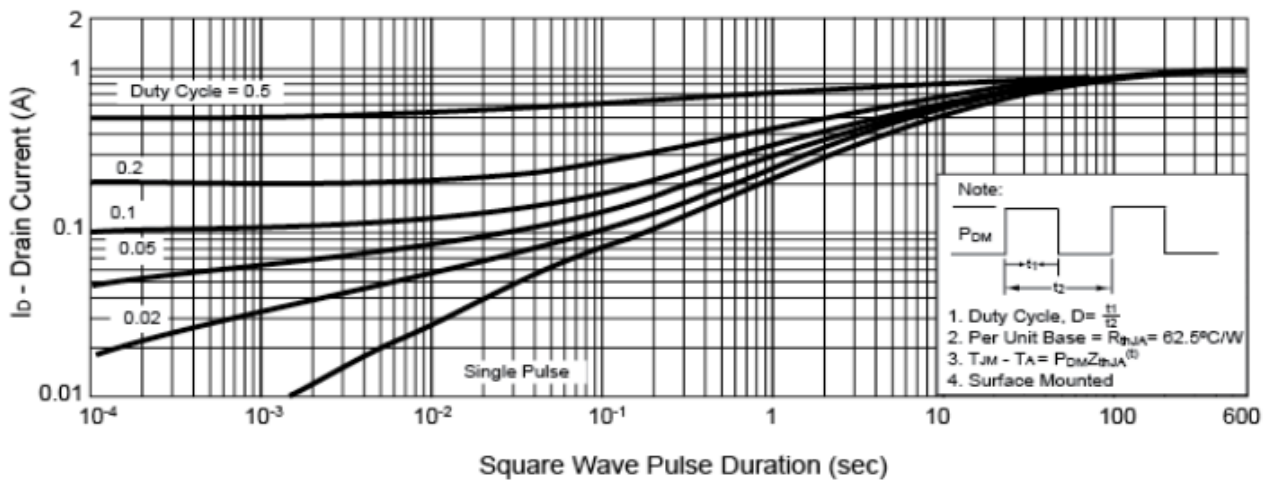
Transfer Characteristics

On-Resistance vs. Drain Current

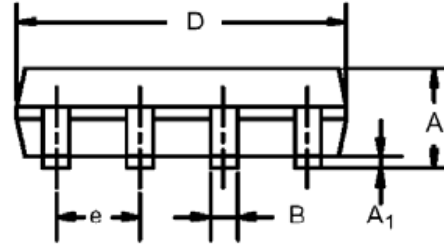
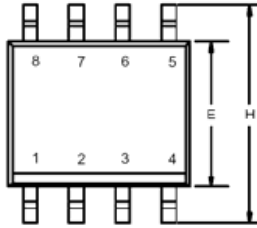
Gate Charge

On-Resistance vs. Junction Temperature

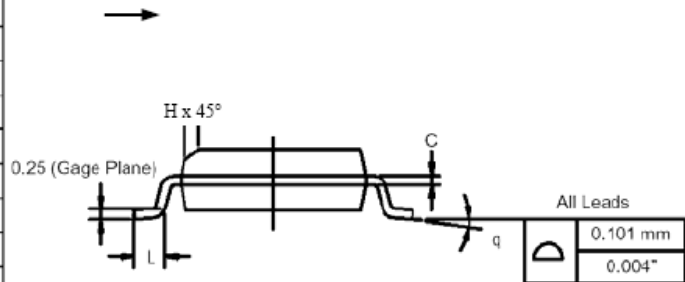
Source-Drain Diode Forward Voltage

Typical Electrical Characteristics
On-Resistance vs. Gate-Source Voltage

Threshold Voltage

Single Pulse Power

Normalized Thermal Transient Impedance, Junction-to-Ambient

Package Information
SOP-8 : 8LEAD



Dim	MILLIMETERS		INCHES	
	Min	Max	Min	Max
A	1.35	1.75	0.053	0.069
A₁	0.10	0.20	0.004	0.008
B	0.35	0.51	0.014	0.020
C	0.19	0.25	0.0075	0.010
D	4.80	5.00	0.189	0.196
E	3.80	4.00	0.150	0.157
e	1.27 BSC		0.050 BSC	
H	5.80	6.20	0.228	0.244
h	0.25	0.50	0.010	0.020
L	0.50	0.93	0.020	0.037
q	0°	8°	0°	8°



Ordering Information

Part Number	Working Voltage	Quantity Per Reel	Reel Size
JY4953	30 V	3,000	13 Inch

Tape and Reel Specification

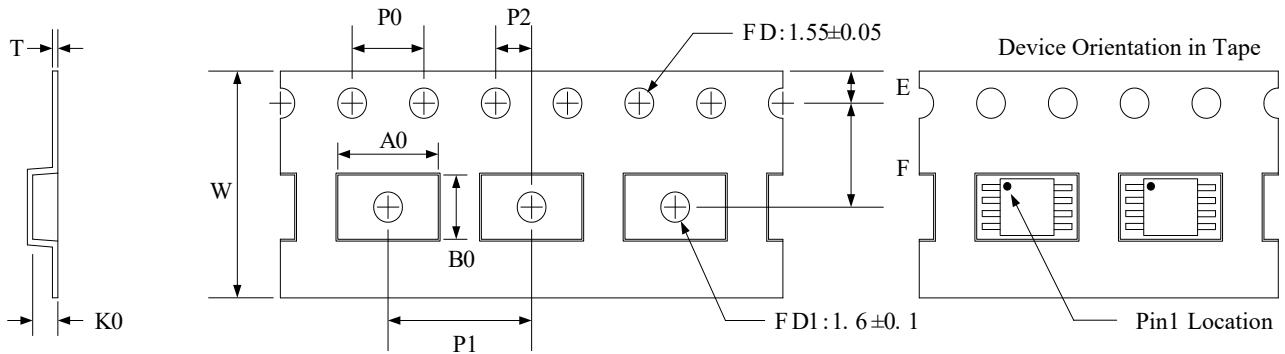

Symbol	W	A0	B0	K0	E	F	P1	P0	P2	T
Dimensions (mm)	12.00±0.3	6.40±0.1	5.2±0.1	2.10±0.1	1.75±0.1	5.50±0.1	8.00±0.1	4.0±0.1	2.0±0.1	0.3±0.05

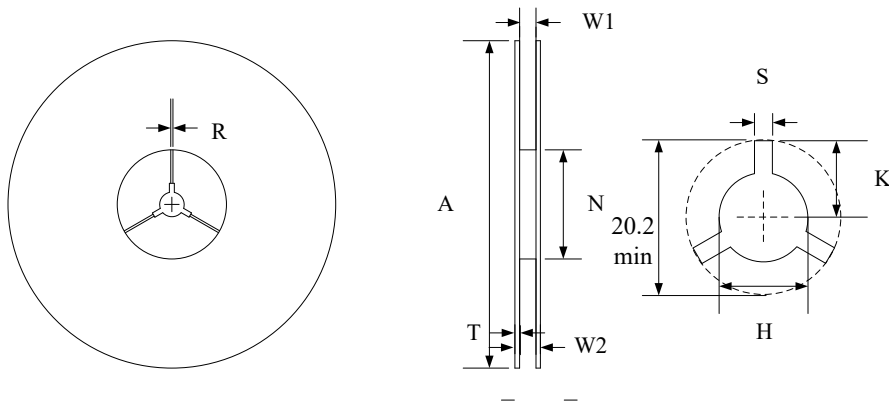

Symbol	Reel Size	A	N	W2	W1	H	T	S	K	R
Dimensions (mm)	Φ330	330.0±2.0	100.0±2.0	18.4 max	12.4+2.0 -0.0	13.0+0.5 -0.2	2.0±0.2	1.5 min	10.1 min	2.5 min