

0805 F

Engineer's Kit: EK-0805F-X

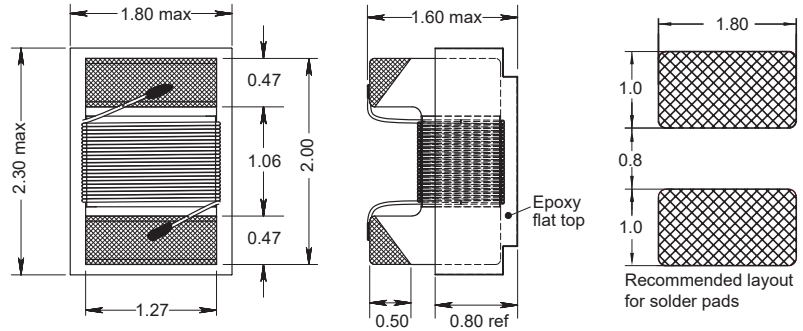
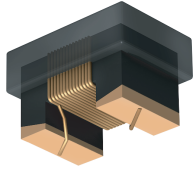

(Wire wound - open)

Chip Inductors for RF Applications

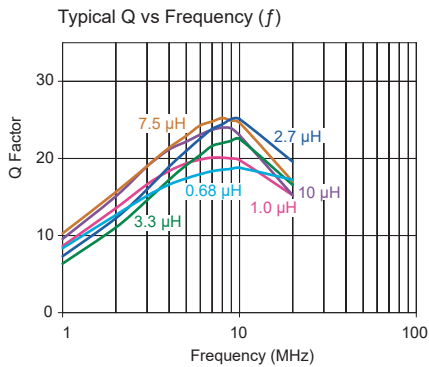
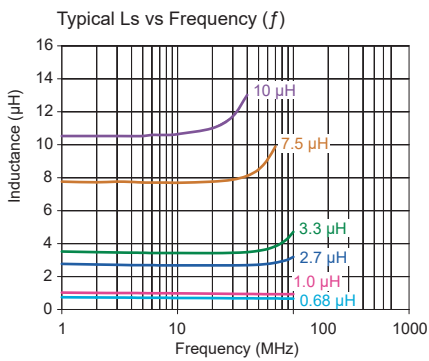

Part No	Inductance	f_L	Tol	Q	f_Q	SRF	DCR	Rated DC
	L (µH)	(MHz)	± (%)	min	(MHz)	(MHz)	max (Ω)	Current (mA)
0805F-R68K-YY	0.68	25.2	10	18	7.9	350 min	0.50	450
0805F-R82K-YY	0.82	25.2	10	18	7.9	350 min	0.55	400
0805F-1R0K-YY	1.0	7.9	10	20	7.9	350 min	0.50	250
0805F-1R2K-YY	1.2	7.9	10	20	7.9	300 typ	0.65	220
0805F-1R5K-YY	1.5	7.9	10	20	7.9	250 typ	0.75	200
0805F-1R8K-YY	1.8	7.9	10	20	7.9	200 typ	0.85	190
0805F-2R2K-YY	2.2	7.9	10	20	7.9	200 typ	1.70	130
0805F-2R7K-YY	2.7	7.9	10	20	7.9	200 typ	2.0	120
0805F-3R3K-YY	3.3	7.9	10	20	7.9	200 typ	3.3	100
0805F-3R9K-YY	3.9	7.9	10	20	7.9	150 typ	3.6	95
0805F-4R7K-YY	4.7	7.9	10	20	7.9	150 typ	3.8	90
0805F-5R6K-YY	5.6	7.9	10	20	7.9	80 typ	2.8	175
0805F-6R2K-YY	6.2	7.9	10	20	7.9	70 typ	3.0	165
0805F-6R8K-YY	6.8	7.9	10	20	7.9	65 typ	3.1	160
0805F-7R5K-YY	7.5	7.9	10	20	7.9	60 typ	3.4	160
0805F-8R2K-YY	8.2	7.9	10	20	7.9	55 typ	3.7	160
0805F-9R1K-YY	9.1	7.9	10	20	7.9	50 typ	3.7	150
0805F-100K-YY	10	7.9	10	20	7.9	45 typ	3.8	150
0805F-120K-YY	12	7.9	10	18	7.9	25 typ	4.2	150
0805F-150K-YY	15	7.9	10	18	7.9	25 typ	5.0	150
0805F-220K-YY	22	7.9	10	15	7.9	30 typ	6.0	97

Core Material: Ferrite

Revision date: 11 Jan 2022

SPQ: Taped / Reel
1000 [-08]
2500 [-01]
7500 [-04]

Remarks: - Unlisted inductance values available upon request.
- 2% and 5% tolerance available upon request.