

CLASS No.	TITLE 20形単連本' リューム規格書 20mm Size Single unit Rotary Potentiometer Specification	TYPE - C
-----------	--	----------

1. 一般事項 General

1-1 適用範囲 Scope

この仕様書は主として電子機器に用いる20形本' リュームに適用する。

This specification applies to 20mm size rotary potentiometer, used in electronic equipment.

1-2 標準状態 Standard atmospheric conditions

測定は特に指定のない限り、次の状態で行なう。

Unless otherwise specified, the standard range of atmospheric conditions for making measurements and tests are as follows:

- 温度 Ambient temperature : 15°C to 35°C
- 相対湿度 Relative humidity : 25% to 85%
- 気圧 Air pressure : 860hPa to 1060hPa

但し、疑義を生じた場合は、次の基準状態で行なう。

If there is any doubt about the results, measurements shall be made within the following limits:

- 温度 Ambient temperature : 20 ± 1°C
- 相対湿度 Relative humidity : 63% to 67%
- 気圧 Air pressure : 860hPa to 1060hPa

1-3 使用温度範囲

Operating temperature range : -30°C to +80°C

1-4 保存温度範囲

Storage temperature range : -40°C to +85°C

2. 電気的性能 Electrical characteristics

項目 Item	条件 Conditions	規格 Specifications
2-1 公称全抵抗値 および許容差 Nominal total resistance and tolerance	端子1-3間にて、測定する。 Between terminals 1 and 3.	3 kΩ ± 20%
2-2 定格電力 Power rating	端子1と3の間に連続負荷することが出来る最大電力。 周囲温度に対する、電力軽減曲線は下図とする。 Power rating is based on continuous full load operation at maximum voltage between term. 1 and 3. Power rating vs ambient temperature shall be denoted on the following graph.	0.05W
2-3 定格電圧 Rating voltage	定格電圧 Rating voltage $E = \sqrt{PR}$ P: 定格電力 Power rating (W) R: 公称全抵抗値 Nominal total resistance (Ω) 但し、定格電圧が最高使用電圧を超える場合には、この最高使用電圧を定格電圧とする。 When the rated voltage exceeds the maximum operating voltage, the maximum operating voltage shall be the rated voltage.	最高使用電圧 Maximum operating voltage A. C. 50V D. C. 30V

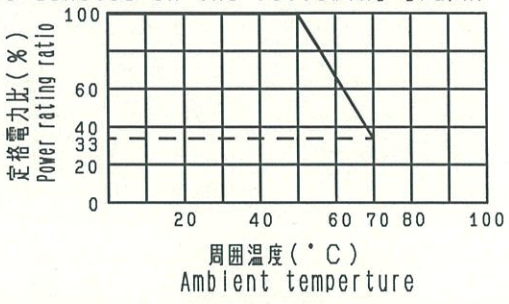

ALPS ELECTRIC CO., LTD.

APPD.	CHKD.	DSGD.	TITLE 20形単連本' リューム 20mm Size Single unit Rotary Potentiometer		
浦・設計試作 07.2.2 池之上		浦・設計試作 07.2.2 木村	DOCUMENT NO. 5K20110E0Y		
SYMB	DATE	APPD	CHKD	DSGD	(1/4)

CLASS No.	TITLE 20形単連ホリウム規格書 20mm Size Single unit Rotary Potentiometer Specification	TYPE-C
-----------	---	--------

項目 Item	条件 Conditions	規格 Specifications
2-4 抵抗変化特性 Resistance taper	電圧法にて測定： $\frac{1-2 \text{ 端子間出力電圧}}{1-3 \text{ 端子間入力電圧}} \times 100(\%)$ Measurement method: the voltage devid $\frac{\text{Output Voltage, across term. 1-2}}{\text{Input Voltage, across term. 1-3}} \times 100(\%)$	クリック位置 Detent position
		1端子末端より From end of CCW
		規格 Specifications
		1 0° 5%以下
		2 20° 20 ~ 30%
		3 40° 45 ~ 55%
4 60° 70 ~ 80%		
5 80° 95%以上		
カーブ図参照 (RK203-B17) See taper figure		
2-5 しゅう動雑音 Noise	規定せず Not specified	
2-6 絶縁抵抗 Insulation resistance	端子-軸受間D. C. 50V印加する。 Measurement shall be made under the condition which a voltage of 50VD.C. is applied between individual terminals and bushing.	端子-軸受間にて10MΩ以上 Between individual terminals and bushing: 10MΩ MIN.
2-7 耐電圧 Dielectric strength	端子-軸受間A. C. 50V1分間又は、A. C. 60V1秒間印加する。 (リーク電流1mA) A voltage of 50VA.C. shall be applied for 1min or a voltage of 60VA.C. shall be applied for 1s between individual terminals and bushing. (Leak current:1mA)	損傷・アーク・絶縁破壊がないこと。 Without damage to parts, arcing or breakdown.

3. 機械的性能 Mechanical characteristics

項目 Item	条件 Conditions	規格 Specifications
3-1 全回転角度 Total rotational angle		80° ± 3°
3-2 クリック Detent	クリック位置 Detent position	5点クリック 5 detents (ステップ角度 20° ± 3°) (Step angle: 20° ± 3°)
	クリックトルク Detent torque	46 ± 19 mN・m

					ALPS ELECTRIC CO., LTD.					
					APPD. 浦・設計試作 07.2.2 池之上	CHKD.	DSGD. 浦・設計試作 07.2.2 木村	TITLE 20形単連ホリウム 20mm Size Single unit Rotary Potentiometer		
SYMB	DATE	APPD	CHKD	DSGD				DOCUMENT NO.	5K20110E0Y (2/4)	

CLASS No.	TITLE 20形単連ホ'リューム規格書 20mm Size Single unit Rotary Potentiometer Specification	TYPE-C
-----------	---	--------

項目 Item	条件 Conditions	規格 Specifications						
3-3 軸の回転止め強度 Shaft stopper strength	軸にネジ'リモーメントを両末端に10秒加える。 Rotation moment shall be applied to the shaft for 10 seconds at both ends.	0.5N・m						
3-4 軸の押し引き強度 Push-pull strength of shaft	軸の押し及び引き方向に100Nの力を10秒間加える。 (セット実装状態) Push and pull static load of 100N shall be applied to the shaft in the axial direction for 10s. (After installing)	軸の破損、著しいガタのないこと。 感触に異常がないこと。 Without damage or excessive play in shaft. No excessive abnormality in rotational feeling.						
3-5 ナット締付強度 Nut tightening strength	1N・mのトルクでナットを締付ける。ただし、ナット上部が軸受上部より1mm以上沈んだ状態で使用されている場合とする。 Installation torque of 1N・m shall be applied to tighten the nut. However, the upper part of the nut shall be set 1mm or more lower than upper part of the bushing.	回転ムラを生じないこと。 Without rotational deviation.						
3-6 軸ガタ Shaft wobble	取付面より30mmの位置に50mN・mの曲げモーメントを加える。 軸長が30mmに満たない場合は右の式による。Lは測定位置(取付面からの位置)とする。 Bending moment of 50mN・m to be applied to the shaft at 30mm from the mounting surface. If the shaft length is less than 30mm, the value shall be calculated as right formula. L: Measurement point from mounting surface.	<table border="1"> <thead> <tr> <th>軸受長 Bushing length (mm)</th> <th>軸力'タ Wobble 以下 (mmp-p less)</th> </tr> </thead> <tbody> <tr> <td>7</td> <td>0.5xL/30</td> </tr> <tr> <td>10</td> <td>0.4xL/30</td> </tr> </tbody> </table>	軸受長 Bushing length (mm)	軸力'タ Wobble 以下 (mmp-p less)	7	0.5xL/30	10	0.4xL/30
軸受長 Bushing length (mm)	軸力'タ Wobble 以下 (mmp-p less)							
7	0.5xL/30							
10	0.4xL/30							
3-7 軸のスラスト方向力'タ Shaft axial free play		0.4mm max.						
3-8 軸の回転方向力'タ Shaft rotational free play		3° max.						
3-9 取付け上の注意 Notice for mounting	軸受をネジ止めするか、右図の様にボリューム本体を抑えてご使用下さい。セット側でボリューム本体の引き及び回転方向の力'イト'が無い場合は、はんだ付けだけの固定となり、はんだ付け信頼性及びスイッチ本体強度が不安定となる可能性があります。 Please mount the POT to the chassis by tightening the nut on the bushing, or hold the bushing using front panel or light pipe. If the bushing is not held, soldering reliability and/or POT body strength may be unstable.							

ALPS ELECTRIC CO., LTD.				
SYMB	DATE	APPD	CHKD	DSGD
		APPD. 浦上設計 07.2.2 池之上	CHKD.	DSGD. 浦上設計 07.2.2 木村
		TITLE 20形単連ホ'リューム 20mm Size Single unit Rotary Potentiometer		DOCUMENT NO. 5K20110E0Y
				(3/4)

CLASS No.	TITLE 20形単連ホ" リューム規格書 20mm Size Single unit Rotary Potentiometer Specification	TYPE-C
-----------	--	--------

4. 耐久性能 Endurance characteristics.

項目 Item	条件 Conditions	規格 Specifications
4-1 しゅう動寿命性能 Rotational life	無負荷で軸を毎時500往復の速さで、全回転角度の90%以上にわたり回転させる。 The shaft shall be turned at a speed of 500cycles/hour and over 90% of the total totational angle.	30,000往復以上 30,000cycles or more 全抵抗値変化: 初期値の±15% Variation in total resistance: ±15% of initial クリックトルク: 初期規格値に対し ±50% Detent torque: ±50% of initial specification

ALPS ELECTRIC CO., LTD.

					APPD. 浦上設計試作 07.2.2 池之上	CHKD.	DSGD. 浦上設計試作 07.2.2 木村	TITLE 20形単連ホ" リューム 20mm Size Single unit Rotary Potentiometer
SYMB	DATE	APPD	CHKD	DSGD	DOCUMENT NO. 5K20110E0Y			(4/4)

ALPS ELECTRIC CO., LTD.

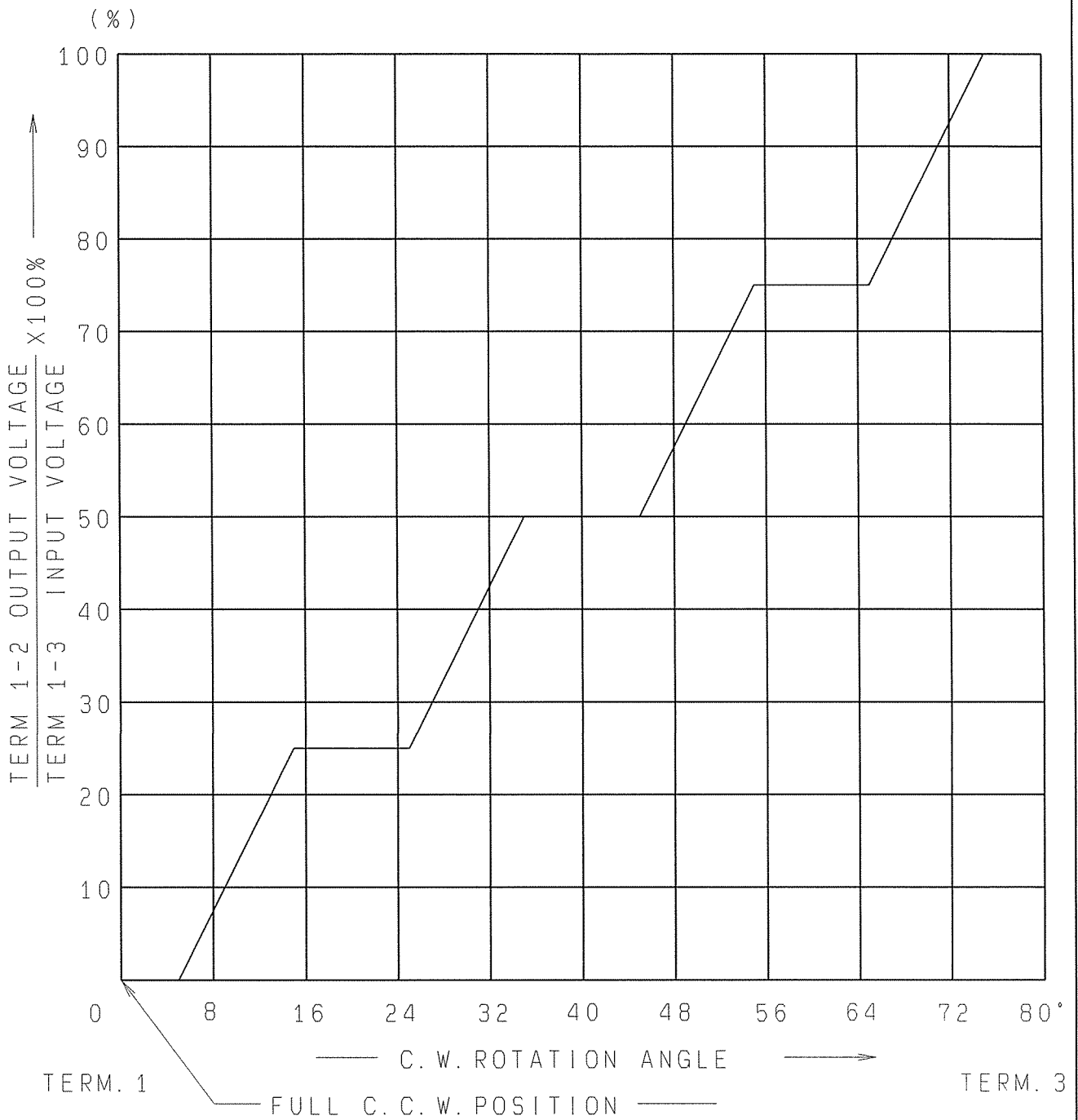

AT 0° C. W. SHAFT ROTATION FROM FULL C. C. W. POSITION, VOLTAGE PERCENT SHALL FALL WITHIN THE LIMITS OF 5 PERCENT MAX.
 AT 20° C. W. SHAFT ROTATION FROM FULL C. C. W. POSITION, VOLTAGE PERCENT SHALL FALL WITHIN THE LIMITS OF 20-30 PERCENT.
 AT 40° C. W. SHAFT ROTATION FROM FULL C. C. W. POSITION, VOLTAGE PERCENT SHALL FALL WITHIN THE LIMITS OF 45-55 PERCENT.
 AT 60° C. W. SHAFT ROTATION FROM FULL C. C. W. POSITION, VOLTAGE PERCENT SHALL FALL WITHIN THE LIMITS OF 70-80 PERCENT.
 AT 80° C. W. SHAFT ROTATION FROM FULL C. C. W. POSITION, VOLTAGE PERCENT SHALL FALL WITHIN THE LIMITS OF 95 PERCENT MIN.

					DSGD.		TITLE
					<i>K. Sasaki May 01 '06</i>		RESISTANCE TAPER
					CHKD.		DOCUMENT NO.
					APPD.	UNIT	RK203-B17
SYMB	DATE	APPD	CHKD	DSGD	<i>K. Matsukawa May 1 '06</i>	m m	

CLASS No.	TITLE
-----------	-------

1. はんだ耐熱 Resistance to soldering heat

下記の“はんだ付け条件”にて絶縁体の変形、破損のないこと、感熱に異常のないこと。
 At the specified by the soldering conditions below.
 There shall be no deformation or cracks, in molded part.
 No excessive abnormality in rotational feeling.

はんだ付け条件 Soldering conditions

手はんだの場合 Manual soldering

温度300°C以下、時間3秒以内
 Bit temperature of soldering iron : 300°C or less.
 Application time of soldering iron : within 3s.

ディップはんだの場合 Dip soldering

使用基板 : t1.6片面銅箔積層板
 Printed wiring board: Single-sided copper clad laminate board with thickness of 1.6mm.

フラックス : 比重0.82以上のフラックスを用い発泡式フラクサーにて発泡面高さは、基板厚の3分の2。

Flux:
 ・Specific gravity: 0.82 or more.
 ・Flux shall be applied to the board using a bubble foaming type fluxer.
 ・The board shall be soaked in the flux bubble only to the 2/3 of its thickness.

プリヒート : 基板表面温度100°C以下、時間2分以内
 Preheating:
 ・Surface temperature of board: 100°C or less.
 ・Preheating time: within 2 min.

はんだ : 温度260±5°C、時間5±1秒
 Soldering:
 ・Solder temperature: 260±5°C.
 ・Immersion time: Within 5±1s.

以上の工程を1回または2回通過する。
 Apply the above soldering process for 1 or 2 times.

2. はんだ付け時の注意事項 Note for soldering method.

下図のようにP. C. B. の上面にはんだ付けをする配線は、お避けください。
 Please avoid soldering on upper surface (the component side surface) of the PC board as shown below.

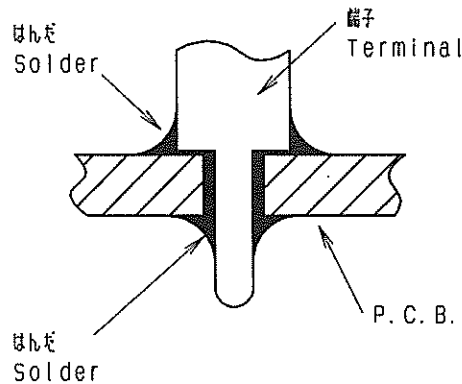

					ALPS ALPS ELECTRIC CO., LTD.	
		APPD. 1枚-2G '00. 9. 25 蔵谷	CHKD.	DSGD. 1枚-2G '00. 9. 22 川野	TITLE _____	
SYMB	DATE	APPD	CHKD	DSGD	DOCUMENT NO. 5K20110-01 (1/1)	

NOTE: BUSHING MATERIAL- ZINC ALLOY DIE CASTING
SHAFT MATERIAL- ALUMINIUM

下図は軸を反時計方向に回しきった状態を示す
SHAFT SHOWN IN FULL OF
CCW POSITION

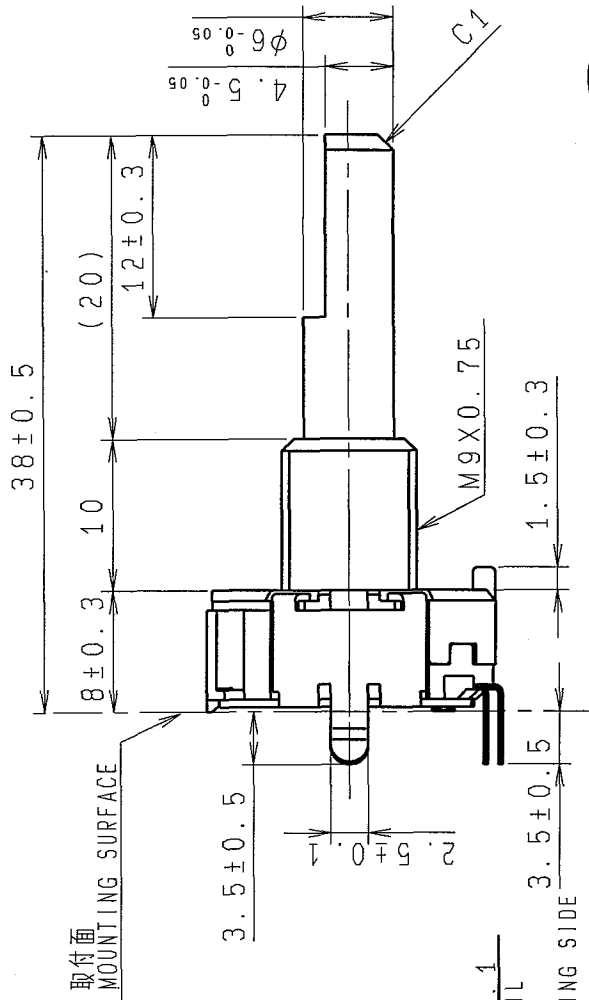

取付穴寸法図 許容差: ±0.1
PWB MOUNTING DETAIL
TOLERANCE: ±0.1
VIEWED FROM MOUNTING SIDE

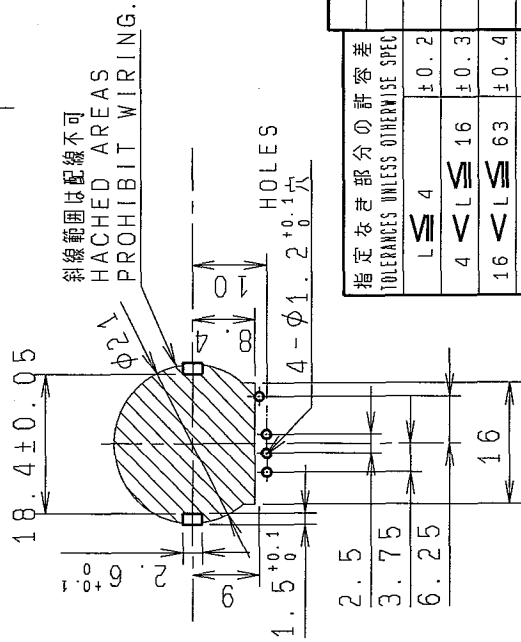

基板厚 T = 1.6mm
P.W. Board
THICKNESS

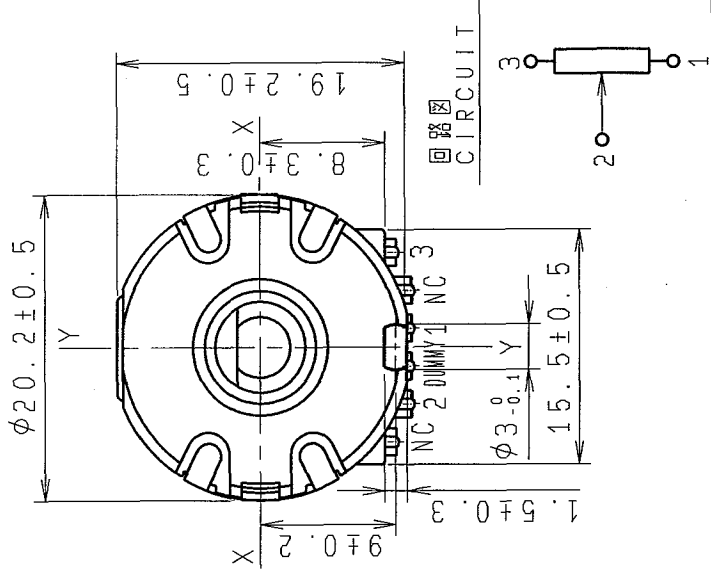
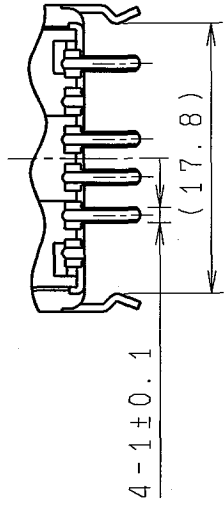

PART NO.	MATERIAL	SPEC/NAME	FINISH
			80° 5C TYPE-C
ALPS ELECTRIC CO., LTD.			
DSGD. 産産技術-9960015		SCALE	NO.
K. SASAKI 2006-09-12		2:1	
CHKD.	Y. OHYA 2006.09.12	TITLE	20形1軸可変抵抗器組立図
初設	2006-08-30 H.K.	UNIT	mm
SYMB	DATE	APPD	DOCUMENT NO.
			K20110EOW

指定なき部分の許容差 TOLERANCES UNLESS OTHERWISE SPEC	角 度	角 度	角 度	角 度	角 度	角 度	角 度
L ≦ 4	±0.2						
4 < L ≦ 16	±0.3						
16 < L ≦ 63	±0.4						
63 < L ≦ 250	±0.5						
250 < L	±0.7						
角 度		角 度		角 度		角 度	
±5°		±5°		±5°		±5°	

OR