



# Economical long-life light sources with plug-in bases

Compact fluorescent lamps  
OSRAM DULUX®  
Technical Guide

SEE THE WORLD IN A NEW LIGHT

**OSRAM**



<b>1</b>	<b>General</b>	<b>3</b>
1.1	Introduction	3
1.2	The OSRAM DULUX® range	4
1.3	Economy	8
1.4	Technical design and operation	9
1.4.1	Radio interference suppression	10
1.5	What accessories are needed for OSRAM DULUX® lamps?	11
<b>2</b>	<b>Lamp data</b>	<b>12</b>
2.1	Geometric data	12
2.1.1	OSRAM DULUX® S	12
2.1.2	OSRAM DULUX® S/E	12
2.1.3	OSRAM DULUX® D	13
2.1.4	OSRAM DULUX® D/E	13
2.1.5	OSRAM DULUX® T	14
2.1.6	OSRAM DULUX® T/E	14
2.1.7	OSRAM DULUX® T IN	15
2.1.8	OSRAM DULUX® T/E IN	15
2.1.9	OSRAM DULUX® L	16
2.1.10	OSRAM DULUX® L SP	16
2.1.11	OSRAM DULUX® F	17
2.2	Operating modes and electrical data	18
2.2.1	Electronic operation	18
2.2.2	Inductive operation – Single-lamp circuit	19
2.2.3	Inductive operation – Series circuit	20
2.2.4	Inductive operation – Lead-lag circuit	20
2.3	Photometric data	21
2.3.1	Light colours	21
2.3.2	Colour specifications	22
2.3.3	Chromaticity coordinates tolerance fields	22
2.3.4	OSRAM DULUX® - light colours	23
2.3.5	Factors affecting colour consistency	24
2.3.6	Spectral distribution	25
2.3.7	Radiation components in the ultra-violet range	26
2.3.8	Radiation components in the infra-red range	27
2.3.9	Luminous intensity distribution curves	28
2.3.10	Luminance of OSRAM DULUX® lamps	30
2.4	Lamp life and loss of luminous flux	31
2.4.1	Definitions	31
2.4.2	Maintenance, loss of luminous flux for OSRAM DULUX® lamps	32
2.4.3	Mortality curves of OSRAM DULUX® lamps	33
2.4.4	Effect of switching operations on lamp life	34
<b>3</b>	<b>Circuits</b>	<b>35</b>
3.1	Operation with electronic control gear (ECG)	35
3.2	Operation with conventional control gear (CCG)	35
3.2.1	Permissible lamp/CCG combinations and system data	36
3.2.2	Compensation	37
3.2.3	Operation of OSRAM DULUX® S/E, D/E und T/E with external starter and CCG	38
3.3	Operating on dc sources	39
3.3.1	Suitable OSRAM ECGs for dc operation	39
3.4	Operation with motion detectors and light sensors	40
3.5	Dimensioning of automatic circuit breakers	40
<b>4</b>	<b>Operating characteristics</b>	<b>41</b>
4.1	Start-up characteristics	41
4.1.1	Single circuit, inductive operation	41
4.1.2	Series circuit, inductive operation	41
4.2	Starting at low temperatures	42
4.3	Run-up behaviour	43
4.4	Operating values of the lamps as a function of mains voltage	45

**Compact Fluorescent Lamps OSRAM DULUX®**

Technical Guide

4.5	Operating values of the lamps as a function of ambient temperature	46
4.6	Luminous flux as a function of temperature and burning position	47
4.6.1	Luminous flux/temperature curves for OSRAM DULUX® lamps in general	47
4.6.2	Luminous flux/temperature curves for OSRAM DULUX® IN lamps for indoor lighting	48
4.6.3	Luminous flux/temperature curves for OSRAM DULUX® L SP for outdoor lighting	48
4.6.4	Operation at high temperatures	49
4.6.5	Operation at low temperatures	49
4.7	Dimming	50
4.7.1	Dimming of OSRAM DULUX®.../E IN amalgam lamps	50
4.8	Lamp temperatures and limit values	51
4.8.1	Maximal temperatures for OSRAM DULUX® lamps	52
<b>5</b>	<b>Data for control gear manufacturers</b>	<b>53</b>
5.1	Electronic operation	53
5.1.1	Preheating (ECG operation)	53
5.1.1	Preheating (ECG operation) continued	54
5.1.2	Starting (ECG operation)	55
5.1.3	Operating data for undimmed lamps	56
5.1.4	Dimming	57
5.2	Conventional operation	60
5.2.1	Conventional operation 220 V, 230 V and 240 V/50 Hz	60
5.3	Electrical data for the filaments	61
<b>6</b>	<b>Accessories</b>	<b>62</b>
6.1	Bases and lampholders	62
6.2	Lamp supports	63
6.3	Starters	64
<b>7</b>	<b>Measuring OSRAM DULUX® compact fluorescent lamps</b>	<b>65</b>
7.1	Burning in the lamps	65
7.2	Burning position	66
7.3	Constant photometric values	66
7.4	Electrical measurements	66
7.5	Temperature measurements	66
7.5.1	Ambient temperature	67
7.5.2	Cold spot temperature for amalgam-free lamps	67
7.5.3	Measuring amalgam lamps	67
7.6	Reference lamps	67
<b>8</b>	<b>OSRAM DULUX® and the environment</b>	<b>68</b>
8.1	Contents	68
8.2	Waste disposal	68
<b>9</b>	<b>European and international standards</b>	<b>69</b>
9.1	Relevant standards	69
9.1.1	Lamps and caps	69
9.1.2	Accessories	69
9.1.3	Luminaires	70
9.1.4	Miscellaneous	72
9.1.5	Sources	72
9.2	Declaration of Conformity	73
9.3	CE labelling	74
9.4	Energy Efficiency Index	74
<b>10</b>	<b>Manufacturers of accessories</b>	<b>75</b>
10.1	Manufacturers of lampholders	75
10.2	Manufacturers of control gear	75
10.3	ECG manufacturers DC/emergency operation	78

## 1 General

### 1.1 Introduction

The first compact fluorescent lamps (CFLs) appeared on the European market at the start of the 1980s. Today, compact fluorescent lamps are available in an extremely wide range of models. They have had a significant and lasting effect on luminaire design and lighting applications.

Compact fluorescent lamps can be divided into two main groups:

lamps with pin bases and  
lamps with screw bases

Lamps with E27 and E14 screw bases and integrated control gear (electronic or conventional) are available in wattages from 3 to 24 W and constitute a separate family of lamps. Lamps of this type are the OSRAM DULUX® EL and CIRCOLUX® EL lamps. These ranges are intended as direct replacements for ordinary light bulbs. For detailed technical information on these lamps, please refer to the brochure entitled „OSRAM DULUX® EL Electronic Energy-Saving Lamps – Facts and Technical Data“.

This present guide, however, takes a detailed look at lamps with pin bases.

OSRAM's compact fluorescent lamps with pin bases marketed under the OSRAM DULUX® brand name are available in wattages from 5 to 80 W with luminous flux values of 250 to 6000 lm. This range of values covers a broad spectrum of lamps, including incandescents, fluorescents and HID lamps, with a wide variety of applications.

Lamps with pin bases have a history of constant development, from the single-turn OSRAM DULUX® S models to the latest OSRAM DULUX® T versions with their innovative triple-turn tubes. The development of different shapes and wattages has led to many different types of luminaire for indoor and outdoor lighting. The list includes recessed and surface-mounted luminaires for shops and offices, floor-standing lights, indirect luminaires, workplace and desktop lighting, security lighting, pictogram illumination, street lighting, solar luminaires and downlights. For downlights in particular, pin-based lamps have been instrumental in determining their design, as each successive round of development has produced increasingly shorter lamps of greater light output.

Compact fluorescent lamps from OSRAM, which offer impressive economy thanks to a luminous efficacy of up to 85 lm/W and a lamp life of up to 8000 or 10000 hours depending on the operating mode, are available not only in a wide range of types but also in different light colours. These light colours are classified in colour rendering groups 1B (Ra 80 to 89) and 1A (Ra 90 to 100). The range also includes various models for special applications in medicine, cosmetics and technology.



The following sections present the range of pin-based lamps, their properties, the necessary accessories accompanied by notes on luminaire design, lamp applications and measurement.

1.2 The OSRAM DULUX® range



OSRAM DULUX® lamps are innovative light sources with the following features:

- Small dimensions
- Low power consumption
- High luminous efficacy
- Long life
- Low thermal output
- Different light colours
- Excellent colour rendering
- Wide range of types and wattages



Lamps with integrated starter and two-pin base for conventional operation

<b>OSRAM DULUX® S</b> Super slim	25 W 40 W 60 W 75 W		→ → → →		5 W = 250 lm 7 W = 400 lm 9 W = 600 lm 11 W = 900 lm
-------------------------------------	------------------------------	--	------------------	---	---

OSRAM DULUX® S is a single-turn lamp with a 12 mm tube diameter and G23 two-pin base. The starter components are housed in the lower section of the base. This lamp has already become a classic and is used in a wide range of applications. Many luminaires (wall-mounted, desktop, workplace, low-profile surface-mounted, downlight and outdoor) are built around this basic model of the compact fluorescent lamp.

<b>OSRAM DULUX® D</b> Super short	60 W 75 W 100 W 2 x 75 W		→ → → →		10 W = 600 lm 13 W = 900 lm 18 W = 1200 lm 26 W = 1800 lm
--------------------------------------	-----------------------------------	--	------------------	--	--

OSRAM DULUX® D is a lamp with double-turn tubes, which make it much shorter than the S version. The starter components are housed in the lower section of the G24d base. These lamps are used mainly in single or multi-lamp downlights. They can also be found in a wide variety of indoor and outdoor luminaires.

<b>OSRAM DULUX® T</b> Ultra short	75 W 100 W 2 x 75 W		→ → →		13 W = 900 lm 18 W = 1200 lm 26 W = 1800 lm
--------------------------------------	---------------------------	--	-------------	---	---

OSRAM DULUX® T is a new version with triple-turn tubes for an extremely short overall length.



The starter components are housed in the lower section of the base. The two-pin base is a GX24d base. This type of lamp is ideal for shallow downlights and can also be used in various indoor and outdoor luminaires. OSRAM DULUX® T 13, 18 and 26 W can be used with lampholder systems for OSRAM DULUX® D 13, 18 and 26 W. The only thing to remember is that upper section of the base on the T version is larger.

OSRAM DULUX® T 13, 18 and 26 W lamps can be operated on the same control gear as OSRAM DULUX® D 13, 18 and 26 W lamps.



OSRAM DULUX® S, D, T and T IN lamps with two-pin bases (CCG operation) are not suitable for emergency systems or dc operation.





**Lamps with four-pin bases for operation with electronic control gear (ECG)**

<b>OSRAM DULUX® S/E</b> Super slim for ECG operation	25 W		→		5 W = 250 lm
	40 W				7 W = 400 lm
	60 W				9 W = 600 lm
	75 W				11 W = 900 lm

OSRAM DULUX® S/E are similar to OSRAM DULUX® S lamps in their design. The main differences are the four-pin 2G7 base and the lack of an integrated glow starter. With these lamps the advantage of the benefits of ECG operation can be made use of, such as improved economy and more comfortable light. ECG operation opens up new applications, notably battery operated camping luminaires and emergency lighting (pictogram luminaires).

<b>OSRAM DULUX® D/E</b> Super short for ECG operation	60 W		→		10 W = 600 lm
	75 W				13 W = 900 lm
	100 W				18 W = 1200 lm
	2 x 75 W				26 W = 1800 lm

OSRAM DULUX® D/E with a G24q base is the four-pin version of the classic OSRAM DULUX® D, designed for ECG operation. In conjunction with suitable control gear, this lamp can also be dimmed.

<b>OSRAM DULUX® T/E</b> Ultra short for ECG operation	75 W		→		13 W = 900 lm
	100 W				18 W = 1200 lm
	2 x 75 W				26 W = 1800 lm
	150 W				32 W = 2400 lm
	200 W				42 W = 3200 lm

OSRAM DULUX® T/E with a GX24q four-pin base is an extremely short lamp with the photometric benefits of triple-turn tubes. Designed for ECG operation, these lamps can also be dimmed in conjunction with suitable control gear.

**Lamps with four-pin bases for conventional or ECG operation**

<p><b>OSRAM DULUX® L</b>                  For modern short-run luminaires</p>		<p>18 W = 1200 lm                  24 W = 1800 lm                  36 W = 2900 lm                  40 W* = 3500 lm                  55 W* = 4800 lm                  80 W* = 6000 lm</p> <p><small>* For ECG operation only</small></p>
---	--	---

OSRAM DULUX® L lamps are compact fluorescent lamps with a high luminous flux. They have almost the same luminous flux and power consumption as tubular fluorescent lamps but are less than half as long and are more compact than U-shaped and ring-shaped lamps. OSRAM DULUX® L are the ideal light source for modern space-saving wall and ceiling lighting in offices, shops, exhibition rooms, foyers and canteens. They are also used for display and outdoor lighting.

OSRAM DULUX® L 18, 24 and 36 W lamps can be used with conventional control gear or appropriate electronic control gear, such as QUICKTRONIC®. These lamps can also be dimmed in conjunction with suitable electronic control gear. If used with conventional control gear, a power factor correction capacitor is needed to improve voltage current phase shift.

<p><b>OSRAM DULUX® F</b>                  Perfect for 2 M to 3 M module luminaires</p>		<p>18 W = 1100 lm                  24 W = 1700 lm                  36 W = 2800 lm</p>
--	--	---

OSRAM DULUX® F is a particularly low-profile compact fluorescent lamp with a high luminous flux. Thanks to its compact dimensions, OSRAM DULUX® F is the perfect lamp for area lighting with 2 M to 3 M module luminaires (200 to 300 mm edge length) in the form of square recessed and surface-mounted luminaires or low-profile wall and ceiling luminaires.

OSRAM DULUX® F 18, 24 and 36 W are suitable for CCG and ECG operation. If used with conventional control gear, a power factor correction capacitor is needed to improve voltage current phase shift.



The lamps can only be dimmed with appropriate electronic control gear such as QUICKTRONIC®.

**Lamps for special applications**



In some cases the design of the luminaire or the application itself put special demands on the lamps. The lamps may, for example, have to operate at a high ambient temperature or they may have to ignite and operate at low ambient temperatures. Some of the ranges of existing lamps have been modified to meet these special requirements, most notably the following:

- OSRAM DULUX® T IN (two-pin base)
- OSRAM DULUX® T/E IN (four-pin base) and
- OSRAM DULUX® L SP (four-pin base).

OSRAM DULUX® T IN and OSRAM DULUX® T/E IN with triple-turn tubes have been optimised for certain indoor (IN) applications such as narrow downlights in which high ambient temperatures may occur. Thanks to the special amalgam technique used in these lamps, the luminous flux remains more or less constant over a wide range of temperatures (see 4.6.2). IN version lamps are identical in construction to the OSRAM DULUX® T and T/E lamps except for their rounded tube cross-section at the bend and a shorter discharge tube (about 5 mm shorter).

<b>OSRAM DULUX® T IN</b> <b>Ultra short for indoor applications</b>	100 W 2 x 75 W		→ →		18 W = 1200 lm 26 W = 1800 lm
--	-------------------	--	--------	---	----------------------------------

OSRAM DULUX® T IN has a two-pin GX24d base. These lamps use the same control gear as OSRAM DULUX® D and OSRAM DULUX® T.

<b>OSRAM DULUX® T/E IN</b> <b>Ultra short for ECG operation for indoor applications</b>	100 W 2 x 75 W 150 W 200 W Icon add 70 W = 5200 lm		→ → → → →		18 W = 1200 lm 26 W = 1800 lm 32 W = 2400 lm 42 W = 3200 lm 57 W = 4300 lm
--	--	--	-----------------------	---	--

OSRAM DULUX® T/E IN is the four-pin version with a GX24q base. It uses the same electronic control gear as OSRAM DULUX® D/E and T/E. These lamps can be dimmed with certain restrictions (see 4.7.1).

These lamps are not suitable for emergency lighting to DIN EN 1838. OSRAM DULUX® T/E IN lamps, particularly the high-wattage models, can be used in outdoor luminaires of suitable dimensions.

<b>OSRAM DULUX® L SP</b> <b>Special model for outdoor applications</b>		18 W = 1200 lm 24 W = 1800 lm
---	--	----------------------------------

OSRAM DULUX® L SP for outdoor lighting has been developed specifically for large-volume ventilated luminaires and for cool climates. These lamps produce their maximum luminous flux at a lower temperature than conventional compact lamps (see 4.6.3). Apart from their rounded ends, they are identical in construction to OSRAM DULUX® L lamps and are operated with the same conventional or electronic control gear.





### 1.3 Economy

Compared with incandescent lamps of similar luminous flux, OSRAM DULUX® lamps consume only one quarter to one fifth of the electrical energy. OSRAM DULUX® lamps are particularly economical in applications where the lamps remain switched on for long periods. The following table shows the clear cost savings:

Lamp	OSRAM DULUX® T/E 18 W	OSRAM DULUX® T 18 W	Incandescent lamp
Lamp wattage	18 W	18 W	100 W
CCG losses	-	6 W	-
ECG losses	2 W <sup>1)</sup>	-	-
Total wattage	20 W <sup>1)</sup>	24 W	100 W
Luminous flux	1.150 lm <sup>1)</sup>	1.200 lm	1.380 lm
Lamp life (average life for a 3 h switching cycle)	10.000 h	8.000 h	1.000 h
Hours burned	8.000 h	8.000 h	8 x 1.000 h
Power consumption during 8.000 hours of operation	160 kWh	192 kWh	800 kWh
Electricity costs at € 0,13/kWh 8.000 h	€ 20,80	€ 24,96	€ 104,00
<b>Savings over the life of one OSRAM DULUX® lamp: 8.000 h</b>	<b>€ 83,20</b>	<b>€ 79,40</b>	

<sup>1)</sup> Operated on QT-T/E 1 x 18/230-240

To this figure must be added the savings in relamping costs. An OSRAM DULUX® lamp used with conventional control gear will last around eight times as long as an incandescent lamp, and around ten times as long if it is operated with electronic control gear. The extra cost of purchasing an OSRAM DULUX® lamp will be offset by reduced electricity costs after as little as 1000 hours of operation, depending on the wattage.

Cost/benefit analyses can also be carried out with the OSRAM ECOS program (see OSRAM Lighting Programme on CD-ROM).

**1.4 Technical design and operation**

In OSRAM DULUX® lamps, as in conventional fluorescent lamps, light is generated by a low-pressure gas discharge. Electrical current is conducted through the tube from one electrode to the other. The electrons excite mercury atoms so that they emit optical radiation. This radiation is converted into visible light by the triphosphor coating on the inner wall of the tube.

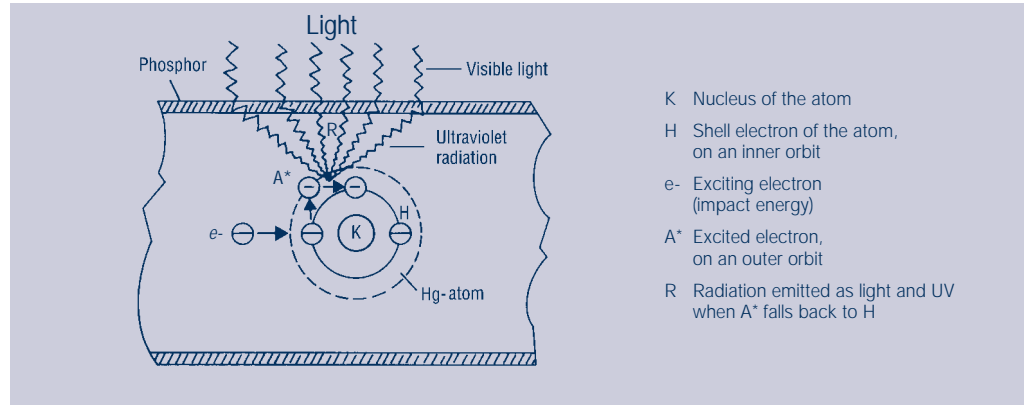

The principle of light generation in a fluorescent lamp

High luminous efficacy (the relationship between luminous flux and power consumption) is achieved when an optimum mercury vapour pressure exists in the discharge tube. This depends on the temperatures on the inner tube wall and is regulated by the vaporisation of mercury and its condensation at the cool zones of the discharge tube.

In contrast to fluorescent lamps, the corners at the top of the discharge tube on an OSRAM DULUX® lamp act as cold spots. The temperature at these cold spots depends to some extent on the burning position of the lamp and the ambient temperature. Good conditions for luminous flux and lamp performance exist when the temperature at these cold spots is between 40°C and 50°C.

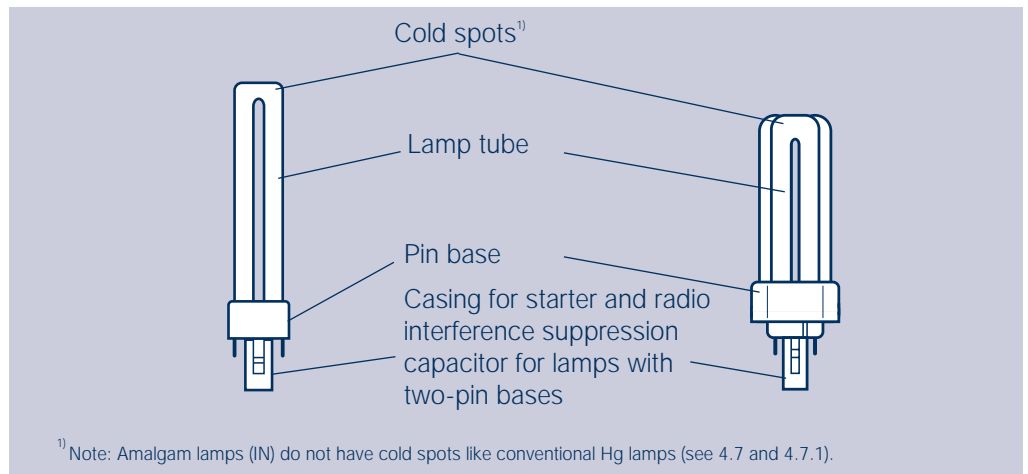

Technical design of OSRAM DULUX® S and OSRAM DULUX® T

This method of generating light needs only one quarter (or one fifth if electronic control gear is used) of the electrical energy which an incandescent lamp of the same brightness would need.

### 1.4.1 Radio interference suppression

Even if used with conventional control gear (50/60 Hz), gas discharge lamps generate electromagnetic radiation in the HF range. This radiation has such a low energy, however, that radio and television transmissions are normally not affected. The HF energy is dissipated as radiation and via cables. The radiated energy decreases so rapidly with distance ( $1/r^2$ ) that the radiation component about one metre from the source is lower than the level of ambient noise.

To prevent interference being carried over the cables, OSRAM DULUX® lamps with two-pin bases have built-in interference suppression capacitors:

Lamps with two-pin bases	Interference suppression capacitor nF
OSRAM DULUX® S 5 W, 7 W, 9 W, 11 W	3,3
OSRAM DULUX® D 10 W, 13 W	3,3
OSRAM DULUX® D 18 W, 26 W	1,2
OSRAM DULUX® T 13 W	3,3
OSRAM DULUX® T 18 W, 26 W <sup>1)</sup>	1,2

<sup>1)</sup> Also for the IN version

An interference suppression capacitor is also built into the external starter used for lamps with four-pin bases that are being operated on conventional control gear. In the case of electronic control gear, ECG manufacturers are responsible for ensuring that their products meet the relevant radio interference suppression requirements (CISPR 15 or EN 55015). In addition, interference suppression will also depend on the way in which cables are routed in the luminaire; this factor may be quite considerable. The luminaire manufacturer must ensure that the luminaire has adequate radio interference suppression.

If an additional interference suppression capacitor is installed in the luminaire, ensure that it is parallel with the mains and not with the lamp.

**Compact Fluorescent Lamps OSRAM DULUX®**

Technical Guide

**1.5 What accessories are needed for OSRAM DULUX® lamps?**

As it is the case with fluorescent lamps, OSRAM DULUX® compact fluorescent lamps (CFLs) require suitable control gears. A distinction is made between lamps with two-pin bases for operation on conventional (magnetic) control gear (CCG) and lamps with four-pin bases for operation on electronic control gear (ECG).

With conventional control gear, a choke is used to limit the current and, in conjunction with the starter housed in the lower section of the base (on OSRAM DULUX® S, D and T) to ignite the lamp. OSRAM DULUX® L and OSRAM DULUX® F lamps require an external starter.

OSRAM DULUX® D 18 W, OSRAM DULUX® T 18 W and OSRAM DULUX® T 18 W IN need special conventional control gear, adjusted to a lamp current of 220 mA. Operation of these lamps on CCG for L 18 W fluorescent lamps with a lamp current of 370 mA will overload the lamps. This will cause serious blackening of the lamp glass in the electrode region and reduce the life of the lamps considerably.

Conventional control gear is available in different versions (with integrated lampholder, for example, or integrated in the mains plug). With some types of lamp, it is possible to connect two lamps in series in conjunction with suitable control gear.

CCG operation is generally an inductive form of operation. In connection with suitable close-tolerance capacitors, capacitive operation (choke and capacitor in series) is also possible. To maintain the prescribed operating and preheating values, close-tolerance capacitors ( $\pm 2\%$ ) and chokes ( $\pm 1,5\%$ ) from renowned manufacturers are needed for series compensation – dielectric strength of the capacitors 450 V ac. However, this mode of operation is suitable only for a few types of lamp (see 3.2).

In addition to what is generally referred to as standard control gear, the group of inductive control gear includes low-loss gear (LLG). As their name suggests, this type of control gear is characterised by its low power loss.

Operating lamps on electronic control gear is a much better option. Apart from the benefits of more comfortable light, longer lamp life and greater luminous efficacy from the system (lamp + ECG), the functions of ignition, current limitation and compensation are all integrated in the ECG. ECGs are also suitable for operation on direct current (which means they can be used in emergency lighting systems) and comply with safety standards (automatic disconnection of faulty lamps, etc.). There are ECG models for most single and double-lamp arrangements. Some models have an integrated lampholder (DULUXTRONIC®, for example).

OSRAM DULUX® lamps are equipped with pin bases. Appropriate lampholders are available as standard products from all leading manufacturers in a wide variety of designs (surface-mounting and push-in lampholders for screw or clamp mounting, for example; see 6.1).

OSRAM DULUX® L lamps need a lamp support in addition to the lampholder. Lamp supports are optional for other OSRAM DULUX® lamps, such as the OSRAM DULUX® S and OSRAM DULUX® F (see 6.2).

2 Lamp data

2.1 Geometric data

The tables below show the maximum overall lengths and the maximum lengths to IEC 60901. These dimensions do not include the clearance required to replace the lamp.

2.1.1 OSRAM DULUX® S

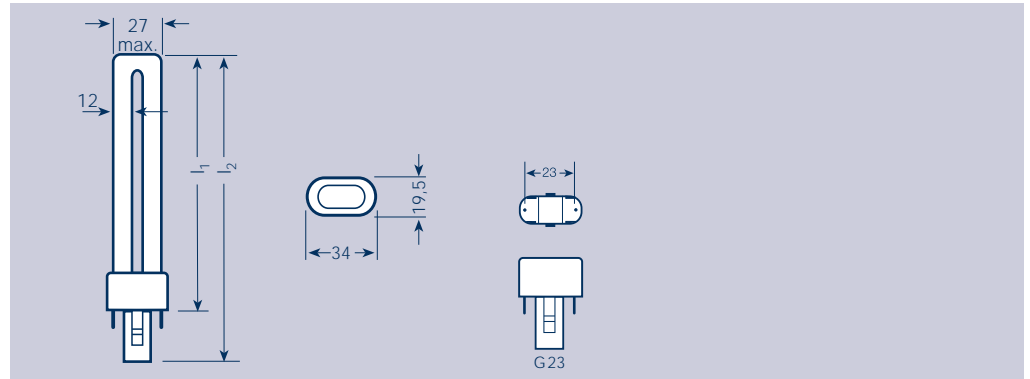

Add geometry on the Icon

Type	Overall length <sup>1)</sup> l <sub>1</sub> max. mm	Overall length <sup>1)</sup> l <sub>2</sub> max. mm	Maximum length l <sub>1</sub> to IEC mm	Base
OSRAM DULUX® S 5 W	85	108	85	G 23
OSRAM DULUX® S 7 W	114	137	115	G 23
OSRAM DULUX® S 9 W	144	167	145	G 23
OSRAM DULUX® S 11 W	214	237	215	G 23

<sup>1)</sup> - 6 mm tolerance

2.1.2 OSRAM DULUX® S/E

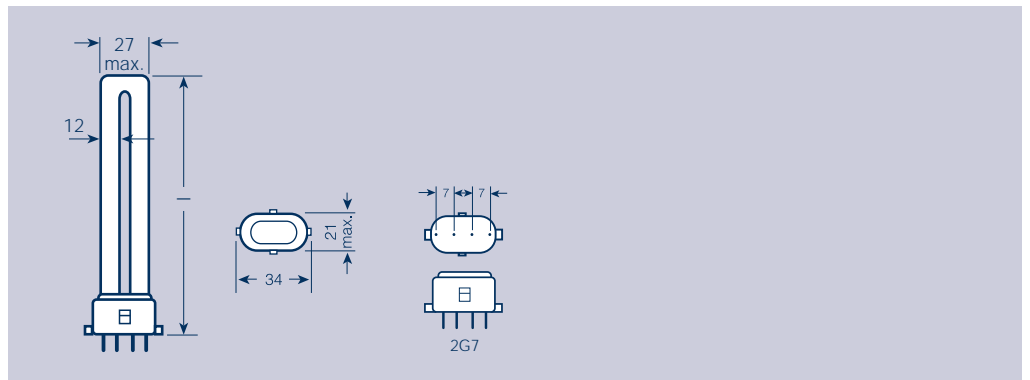

Add geometry on the Icon

Type	Overall length <sup>1)</sup> l max. mm	Maximum length l to IEC mm	Base
OSRAM DULUX® S/E 5 W	85	85	2 G 7
OSRAM DULUX® S/E 7 W	114	115	2 G 7
OSRAM DULUX® S/E 9 W	144	145	2 G 7
OSRAM DULUX® S/E 11 W	214	215	2 G 7

<sup>1)</sup> - 6 mm tolerance



2.1.3 OSRAM DULUX® D

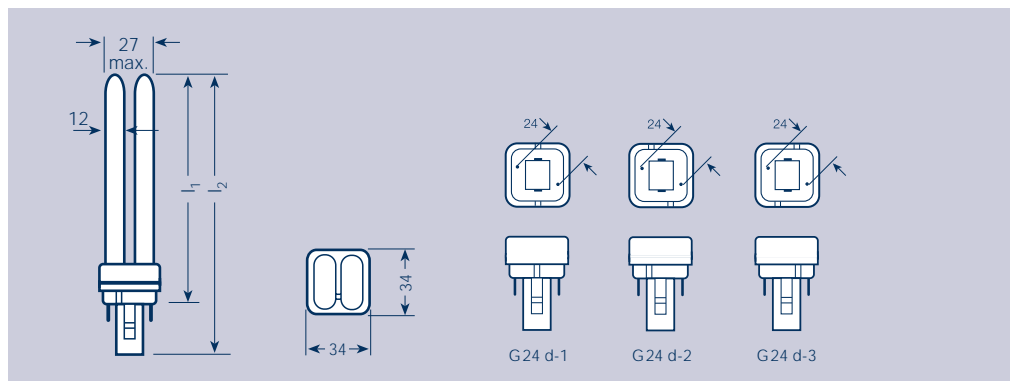

Type	Overall length <sup>1)</sup>		Maximum length l <sub>1</sub> to IEC mm	Base
	l <sub>1</sub> max. mm	l <sub>2</sub> max. mm		
OSRAM DULUX® D 10 W	87	110	95	G 24 d-1
OSRAM DULUX® D 13 W	115	138	130	G 24 d-1
OSRAM DULUX® D 18 W	130	153	140	G 24 d-2
OSRAM DULUX® D 26 W	149	172	160	G 24 d-3

<sup>1)</sup> - 6 mm tolerance

2.1.4 OSRAM  
 DULUX® D/E

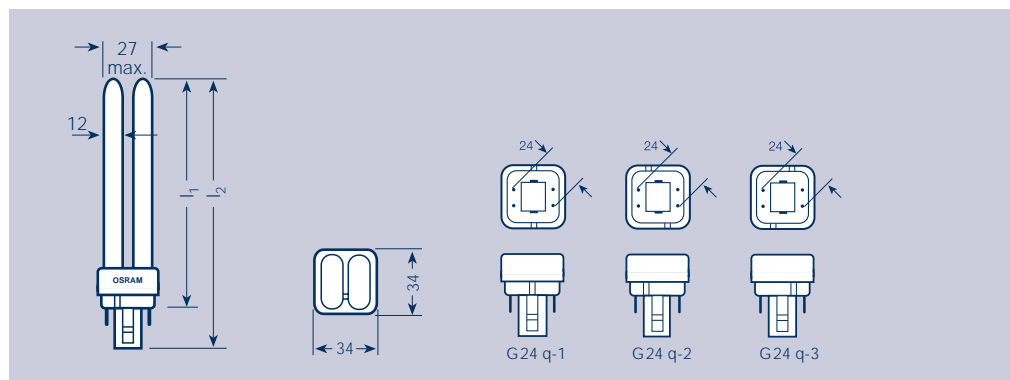

Type	Overall length <sup>1)</sup>		Maximum length l <sub>1</sub> to IEC mm	Base
	l <sub>1</sub> max. mm	l <sub>2</sub> max. mm		
OSRAM DULUX® D/E 10 W	87	103	95	G 24 q-1
OSRAM DULUX® D/E 13 W	115	131	130	G 24 q-1
OSRAM DULUX® D/E 18 W	130	146	140	G 24 q-2
OSRAM DULUX® D/E 26 W	149	165	160	G 24 q-3

<sup>1)</sup> - 6 mm tolerance

2.1.5 OSRAM DULUX® T

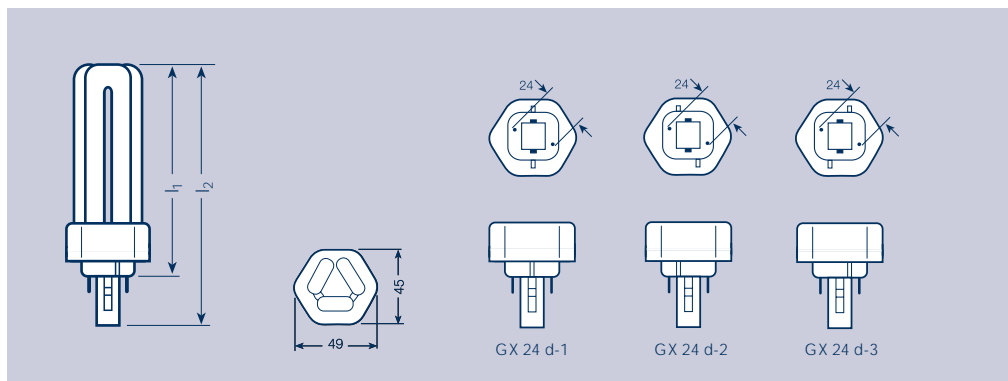

Type	Overall length <sup>1)</sup>		Maximum length $l_1$ to IEC mm	Base
	$l_1$ max. mm	$l_2$ max. mm		
OSRAM DULUX® T 13 W	90	113	90	GX24 d-1
OSRAM DULUX® T 18 W	100	123	110	GX24 d-2
OSRAM DULUX® T 26 W	115	138	130	GX24 d-3

<sup>1)</sup> - 6 mm tolerance

2.1.6 OSRAM  
 DULUX® T/E

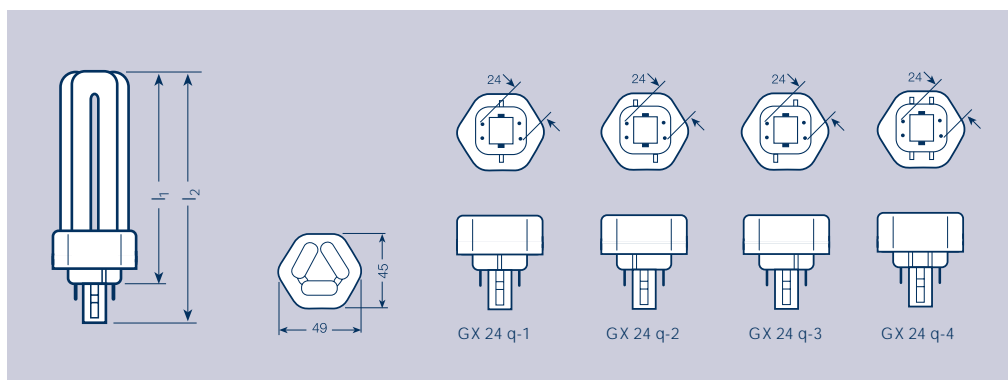

Type	Overall length <sup>1)</sup>		Maximum length $l_1$ to IEC mm	Base
	$l_1$ max. mm	$l_2$ max. mm		
OSRAM DULUX® T/E 13 W	90	106	90	GX24 q-1
OSRAM DULUX® T/E 18 W	100	116	110	GX24 q-2
OSRAM DULUX® T/E 26 W	115	131	130	GX24 q-3
OSRAM DULUX® T/E 32 W	131	147	145	GX24 q-3
OSRAM DULUX® T/E 42 W	152	168	155	GX24 q-4

<sup>1)</sup> - 6 mm tolerance

**2.1.7 OSRAM  
 DULUX® T IN  
 with amalgam**

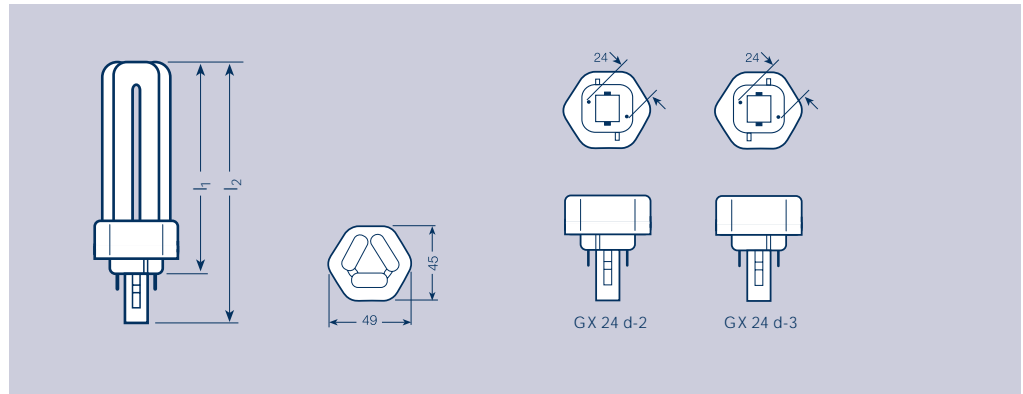

Type	Overall length <sup>1)</sup>		Maximum length l <sub>1</sub> to IEC mm	Base
	l <sub>1</sub> max. mm	l <sub>2</sub> max. mm		
OSRAM DULUX® T 18 W IN	95	118	110	GX24 d-2
OSRAM DULUX® T 26 W IN	110	133	130	GX24 d-3

<sup>1)</sup> - 6 mm tolerance

**2.1.8 OSRAM  
 DULUX® T/E IN  
 with amalgam**

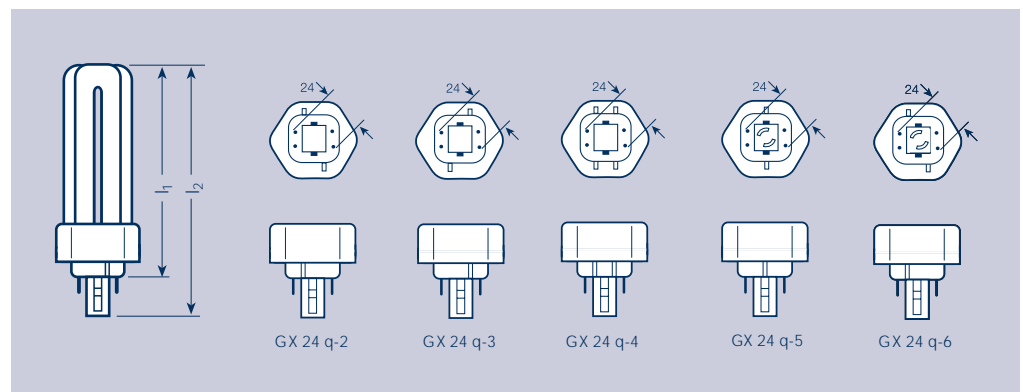

Type	Overall length <sup>1)</sup>		Maximum length l <sub>1</sub> to IEC mm	Base
	l <sub>1</sub> max. mm	l <sub>2</sub> max. mm		
OSRAM DULUX® T/E 18 W IN	95	111	110	GX24 q-2
OSRAM DULUX® T/E 26 W IN	110	126	130	GX24 q-3
OSRAM DULUX® T/E 32 W IN	126	142	145	GX24 q-3
OSRAM DULUX® T/E 42 W IN	147	163	155	GX24 q-4
OSRAM DULUX® T/E 57 W IN	181	197	181	GX24 q-5
OSRAM DULUX® T/E 70 W IN <sup>2)</sup>	219 <sup>2)</sup>	235 <sup>2)</sup>	2)	GX24 q-6

<sup>1)</sup> - 6 mm tolerance

<sup>2)</sup> In preparation, provisional data



2.1.9 OSRAM DULUX® L

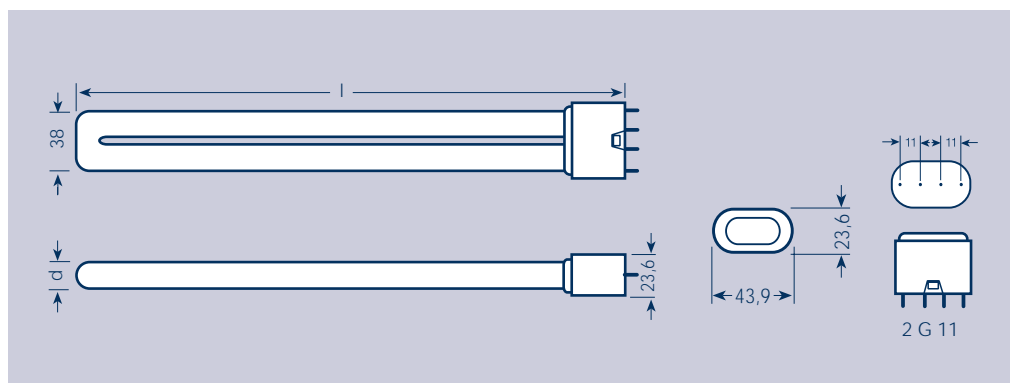

Type	Overall length <sup>1)</sup>		Tube diameter d	Base
	l max.	Maximum length l to IEC		
OSRAM DULUX® L 18 W <sup>2)</sup>	217	225	17.5	2 G 11
OSRAM DULUX® L 24 W <sup>2)</sup>	317	320	17.5	2 G 11
OSRAM DULUX® L 36 W <sup>2)</sup>	411	415	17.5	2 G 11
OSRAM DULUX® L 40 W <sup>2)</sup>	533	535	17.5	2 G 11
OSRAM DULUX® L 55 W <sup>2)</sup>	533	535	17.5	2 G 11
OSRAM DULUX® L 80 W <sup>2)</sup>	570	<sup>3)</sup>	17.5	2 G 11

- 1) - 6 mm tolerance
- 2) OSRAM DULUX® L lamps require a lamp support (see 6.2)
- 3) In preparation

2.1.10 OSRAM  
 DULUX® L SP  
 Special model for  
 outdoor lighting

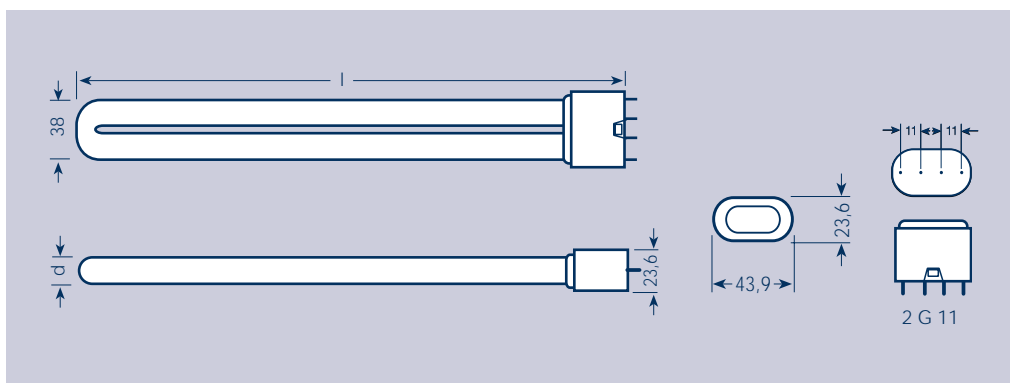

Type	Overall length <sup>1)</sup> l max.	Tube diameter d	Base
OSRAM DULUX® L 18 W SP <sup>2)</sup>	209	17.5	2 G 11
OSRAM DULUX® L 24 W SP <sup>2)</sup>	309	17.5	2 G 11

- 1) - 6 mm tolerance
- 2) OSRAM DULUX® L lamps require a lamp support (see 6.2)

2.1.11 OSRAM  
 DULUX® F

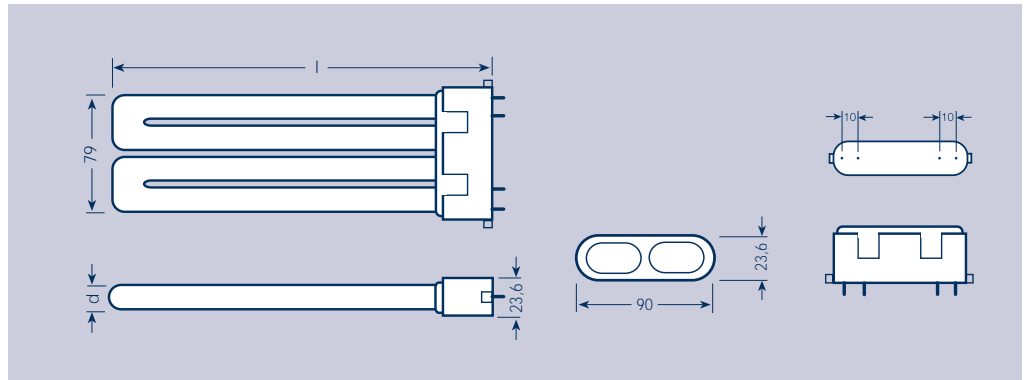

Type	Overall length <sup>1)</sup> l max. mm	Maximum length l to IEC mm	Tube diameter d mm	Base
OSRAM DULUX® F 18 W	122	122	17.5	2 G 10
OSRAM DULUX® F 24 W	165	165	17.5	2 G 10
OSRAM DULUX® F 36 W	217	217	17.5	2 G 10

<sup>1)</sup> - 6 mm tolerance

## 2.2 Operating modes and electrical data

### 2.2.1 Electronic operation

Only OSRAM DULUX® lamps with four-pin bases are suitable for electronic operation. In particular, OSRAM DULUX® L 40 W, 55 W and 80 W and OSRAM DULUX® T/E 32 W, 42 W, 57 W and 70 W are approved exclusively for electronic operation. Single-lamp and two-lamp operation are the most common arrangements for ECG operation.

The following table shows the data for reference lamps:

Measurement conditions

according to IEC 60901:

Operation on reference gear

Operating frequency 25 kHz

Ambient temperature 25°C

Lamps aged for 100 hours

Base-up position for OSRAM DULUX® S/E, D/E, T/E

Horizontal position for OSRAM DULUX® L, F

Lamp reference	Luminous flux	Lamp wattage	Luminous efficacy	Arc voltage	Lamp current
	lm	W	lm/W	V	mA
OSRAM DULUX® S/E 5W	250	5	50	27	190
OSRAM DULUX® S/E 7W	400	6.5	62	37	175
OSRAM DULUX® S/E 9W	600	8	75	48	170
OSRAM DULUX® S/E 11W	850	11	77	75	150
OSRAM DULUX® D/E 10W	600	9.5	63	51	190
OSRAM DULUX® D/E 13W	850	12.5	68	77	165
OSRAM DULUX® D/E 18W	1150	16.5	70	80	210
OSRAM DULUX® D/E 26W	1750	24	73	80	300
OSRAM DULUX® T/E 13W	850	12.5	68	77	165
OSRAM DULUX® T/E 18W <sup>1)</sup>	1150	16.5	70	80	210
OSRAM DULUX® T/E 26W <sup>1)</sup>	1750	24	73	80	300
OSRAM DULUX® T/E 32W <sup>1)</sup>	2400	32	75	100	320
OSRAM DULUX® T/E 42W <sup>1)</sup>	3200	43	74	135	320
OSRAM DULUX® T/E 57W <sup>2)</sup>	4300	57	75	182	320
OSRAM DULUX® T/E 70W <sup>2)3)</sup>	5200	70	74	219	320
OSRAM DULUX® L 18W	1150	16	72	50	320
OSRAM DULUX® L 24W	1750	22	80	75	300
OSRAM DULUX® L 36W	2800	32	88	90	360
OSRAM DULUX® L 40W	3500	40	88	126	320
OSRAM DULUX® L 55W	4800	55	87	101	550
OSRAM DULUX® L 80W	6000	80	75	145	555
OSRAM DULUX® F 18W	1050	16	66	50	320
OSRAM DULUX® F 24W	1650	22	75	75	300
OSRAM DULUX® F 36W	2700	32	84	90	360

<sup>1)</sup> Also as the „IN“ version

<sup>2)</sup> Only as the „IN“ version

<sup>3)</sup> In preparation, provisional data

**2.2.2 Inductive operation  
 Single-lamp circuit**

OSRAM DULUX® S, D, T, F and L lamps can be operated on conventional control gear. In the OSRAM DULUX® S, D and T models the starter necessary for ignition is accommodated in the lower section of the base; a separate starter is needed for OSRAM DULUX® F and L models (see 6.3). Exceptions are the OSRAM DULUX® L 40, 55 and 80 W, which are approved only for high-frequency operation.

OSRAM DULUX® S/E, D/E and T/E and T/E IN lamps (up to 26 W) with four-pin bases can, in principle, be operated with a separate starter but this is not recommended (see 3.2.3).

Measurement conditions

- according to IEC 60901:
- 220 V / 50 Hz supply voltage<sup>1)</sup>
  - Operation on reference gear
  - Ambient temperature 25°C
  - Lamps aged for 100 hours
  - Base-up position for OSRAM DULUX® S, D, T
  - Horizontal position for OSRAM DULUX® L, F

Lamp data (rated values)						Reference control gear data		
Lamp reference	Luminous flux	Lamp wattage	Luminous efficacy	Arc voltage	Lamp current	Calibration current	Impedance	Power factor
	lm	W	lm/W	V	mA	mA	Ω	
OSRAM DULUX® S 5W	250	5.4	46	35	180	170	1180	0.12
OSRAM DULUX® S 7W	400	7.1	56	47	175	170	1180	0.12
OSRAM DULUX® S 9W	600	8.7	69	60	170	170	1180	0.12
OSRAM DULUX® S 11W	900	11.8	76	91	155	170	1180	0.12
OSRAM DULUX® D 10W	600	10	60	64	190	190	1070	0.12
OSRAM DULUX® D 13W	900	13	69	91	175	165	1070	0.12
OSRAM DULUX® D 18W	1200	18	67	100	220	220	800	0.12
OSRAM DULUX® D 26W	1800	26	69	105	325	315	540	0.10
OSRAM DULUX® T 13W	900	13	69	91	175	165	1070	0.12
OSRAM DULUX® T 18W	1200	18	67	100	225	220	800	0.12
OSRAM DULUX® T 26W	1800	26.5	69	105	325	315	540	0.10
OSRAM DULUX® L 18W	1200	18	67	58	375	370	540	0.10
OSRAM DULUX® L 24W	1800	24	75	87	345	340	540	0.10
OSRAM DULUX® L 36W	2900	36	67	106	435	430	390	0.10
OSRAM DULUX® F 18W	1100	18	61	56	375	370	540	0.10
OSRAM DULUX® F 24W	1700	24	71	87	345	340	540	0.10
OSRAM DULUX® F 36W	2800	36	67	106	435	430	390	0.10

<sup>1)</sup> In accordance with IEC 60901, measurements are taken at 220 V/50 Hz on the reference control gear. There is no change, however, in the electrical lamp data for 230 V and 240 V supplies, provided suitable control gear is used.

**2.2.3 Inductive operation  
 Series circuit**

Series circuits (tandem circuits) are possible only for certain types of lamp in which the arc voltage does not exceed certain values (see 3.2.1).

Measurement conditions

- according to IEC 60901: 220 V / 50 Hz supply voltage<sup>1)</sup>
- Operation on reference gear
- Ambient temperature 25°C
- Lamps aged 100 hours
- Base-up position for OSRAM DULUX® S, D, T
- Horizontal position for OSRAM DULUX® L, F

Lamp data						Reference control gear data		
Lamp reference	Luminous flux	Lamp wattage	Luminous efficacy	Arc voltage	Lamp current	Calibration current	Impedance	Power factor
	lm	W	lm/W	V	mA	mA	Ω	
2x DULUX® S 5W	500	11	45	35	180	170	1070	0.12
2x DULUX® S 7W	800	13.7	58	47	160	170	1070	0.12
2x DULUX® S 9W	950	14.4	66	60	130	170	1070	0.12
2x DULUX® L 18W	2500	38	66	58	425	370	390	0.12
2x DULUX® F 18W	2300	38	61	56	425	370	390	0.12

<sup>1)</sup> In accordance with IEC 60901, measurements are taken at 220 V/50 Hz on the reference control gear. There is no change, however, in the electrical lamp data for 230 V and 240 V supplies, provided suitable control gear is used.

**2.2.4 Inductive operation  
 Lead-lag circuit**

With certain lamps in two-lamp inductive arrangements, a lead-lag circuit can be set up in which one of the two CCGs is combined with a series capacitor. For data for the capacitor see 3.2.2.



## 2.3 Photometric data

### 2.3.1 Light colours

The light colours of the lamps are divided into three groups, each covering a particular colour temperature range.

Light colour	Colour temperature
Daylight	> 5000 K
Cool White	3300 - 5000 K
Warm White	< 3300 K

The light colour is determined by the x and y coordinates in the chromaticity table. For practical purposes, it is important to know the colour rendering properties of the lamps in addition to their light colour and colour temperature. These properties are defined by the (general) colour rendering index  $R_a$ .

The colour rendering index (computed using the CIE method) provides an indication of how non-luminous colours will appear when illuminated by the relevant light source. Colour rendering is assessed by comparison with a Planckian radiator (< 5000 K) and normalised daylight ( $\geq 5000$  K) of the same colour temperature. By definition, these radiators have the ideal colour rendering index of 100. Any deviation from this ideal is rated with values lower than 100.

The general colour rendering index  $R_a$  is the average value of eight different internationally standardised test colours (CIE).

There are various ranges for the  $R_a$  value, known as colour rendering groups:

$R_a$ value	Group (according to DIN 5035)	
90 - 100	1A	Very good
80 - 89	1B	Very good
70 - 79	2A	Good
60 - 69	2B	Good
40 - 59	3	Satisfactory
20 - 39	4	Unsatisfactory

Note:

The colour perception of a non-luminous colour therefore always depends on the colour temperature of the illuminating lamp and colour rendering properties of this lamp.

Example:

Blue tones will always appear brighter in the light from a lamp with a daylight colour than in the light from a lamp with a warm white colour, even if both lamps have an  $R_a$  value of 100.

**Compact Fluorescent Lamps OSRAM DULUX®**

Technical Guide

OSRAM DULUX® compact fluorescent lamps are available in LUMILUX® and LUMILUX® DE LUXE light colours. The most economical lighting is achieved with LUMILUX®. These light colours fall into colour rendering group 1B, which means they are ideal for most applications (including office and shop lighting, hotel and restaurant lighting, living rooms and outdoors). In places where colour rendering is a particular important factor (art galleries, museums, laboratories and graphical trades, for example), OSRAM DULUX® lamps are also supplied in LUMILUX® DE LUXE light colours. As group 1A lamps, these offer the best colour rendering. However, because their luminous flux is lower than their LUMILUX® counterparts, more lamps are needed to achieve the same lighting level.

Ultimately, the choice of light colour depends on the specific application, room conditions and personal preference.

**2.3.2 Colour specifications**

The following table shows the various light colours in which OSRAM DULUX® lamps are available, together with their principal colour parameters:

Light colour	Colour temperature	Colour rendering group	Colour rendering index (CRI)
Reference	K	DIN 5035	R <sub>a</sub>
<b>LUMILUX®</b>			
860 LUMILUX® Daylight	6000	1B	≥ 80
840 LUMILUX® Cool White	4000	1B	≥ 80
830 LUMILUX® Warm White	3000	1B	≥ 80
827 LUMILUX INTERNA®	2700	1B	≥ 80
<b>LUMILUX® DE LUXE</b>			
950 LUMILUX® DE LUXE Daylight	5400	1A	≥ 90
940 LUMILUX® DE LUXE Cool White	3800	1A	≥ 90
930 LUMILUX® DE LUXE Warm White	3000	1A	≥ 90
<b>Special light colours<sup>1)</sup></b>			
60 Red	-	-	-
66 Green	-	-	-
67 Blue	-	-	-

1) Lamps with chromaticity coordinates that do not lie in the vicinity of the reference radiators (Judd lines; see CIE calculation method) cannot, by definition, be assigned a colour temperature and hence cannot be assigned a colour rendering index.

**2.3.3 Chromaticity coordinates tolerance fields**

Chromaticity coordinate tolerance fields are ellipses in the chromaticity table which represent the permissible range for the relevant light colour. The tolerances are five threshold units for all light colours (LUMILUX®, LUMILUX® DE LUXE). A threshold unit represents the minimum perceivable difference in colour between two lamps (see also IEC 60901 and IEC 60081).



2.3.4 DULUX®  
 light  
 colours

Type	Luminous flux (lm) for light colour									
	LUMILUX®				LUMILUX® DE LUXE			Special light colour		
	860 Daylight	840 Cool white	830 Warm white	827 INTERNA®	950 Daylight	940 Cool white	930 Warm white	60 Red	66 Green	67 Blue
OSRAM DULUX® S 5W		250	250	250						
OSRAM DULUX® S 7W	375	400	400	400						
OSRAM DULUX® S 9W	565	600	600	600				400	800	200
OSRAM DULUX® S 11W	850	900	900	900						
OSRAM DULUX® S/E 5W		250		250						
OSRAM DULUX® S/E 7W		400	400	400						
OSRAM DULUX® S/E 9W		600	600	600						
OSRAM DULUX® S/E 11W		900	900	900						
OSRAM DULUX® D 10W		600	600	600						
OSRAM DULUX® D 13W		900	900	900						
OSRAM DULUX® D 18W		1200	1200	1200						
OSRAM DULUX® D 26W		1800	1800	1800						
OSRAM DULUX® D/E 10W		600	600	600						
OSRAM DULUX® D/E 13W		900	900	900						
OSRAM DULUX® D/E 18W		1200	1200	1200						
OSRAM DULUX® D/E 26W		1800	1800	1800						
OSRAM DULUX® T 13W		900	900	900						
OSRAM DULUX® T 18W <sup>1)</sup>		1200	1200	1200						
OSRAM DULUX® T 26W <sup>1)</sup>		1800	1800	1800						
OSRAM DULUX® T/E 13W		900	900	900						
OSRAM DULUX® T/E 18W <sup>1)</sup>		1200	1200	1200						
OSRAM DULUX® T/E 26W <sup>1)</sup>		1800	1800	1800						
OSRAM DULUX® T/E 32W <sup>1)</sup>		2400	2400	2400						
OSRAM DULUX® T/E 42W <sup>1)</sup>		3200	3200	3200						
OSRAM DULUX® T/E 57W <sup>2)</sup>		4300	4300	4300						
OSRAM DULUX® T/E 70W <sup>2)3)</sup>		5200	5200							
OSRAM DULUX® L 18W		1200	1200	1200	750	750	750			
OSRAM DULUX® L 24W		1800	1800	1800	1200	1200	1200			550
OSRAM DULUX® L 36W	2750	2900	2900	2900	1900	1900	1900			
OSRAM DULUX® L 40W	3325	3500	3500	3500	2200					
OSRAM DULUX® L 55W	4550	4800	4800	4800	3000	3000	3000			
OSRAM DULUX® L 80W		6000	6000	6000						
OSRAM DULUX® L 18W SP			1200							
OSRAM DULUX® L 24W SP			1800							
OSRAM DULUX® F 18W		1100	1100	1100						
OSRAM DULUX® F 24W		1700	1700	1700						
OSRAM DULUX® F 36W		2800	2800	2800						

1) Also for IN models  
 2) Only for IN models  
 3) In preparation



### 2.3.5 Factors affecting colour consistency

There are a number of factors that affect colour consistency and the perception of the light colour of compact fluorescent lamps.

#### **Iridescence**

Iridescence is a property of some anodised reflector finishes which results in a „rainbow“ effect when use in conjunction with trichrome phosphors. Since all OSRAM DULUX® lamps contain trichrome phosphors, this effect caused by the reflector may be wrongly ascribed to the lamps as „different light colours“.

#### **Ambient temperature**

The light colour of trichrome phosphors changes slightly as the ambient temperature changes because of the relationship between luminous flux and temperature. This is apparent in applications in which, say, open ceiling luminaires are installed close to air-condition outlets. In such cases, the light colour may be slightly different from that of luminaires located further away. This effect can be minimised by coordinating the air-conditioning system with the lighting system.

#### **Manufacturing tolerances**

There may be minimal differences in the light colours of lamps from different manufacturers. In applications in which colour consistency is a critical factor, all the lamps in a particular zone should come from the same manufacturer and should all be replaced together. If lamps are replaced individually there may be differences in light colour.

#### **Dimming**

When fluorescent lamps are dimmed there is a slight reduction in colour temperature. The colour temperature of a fully dimmed OSRAM DULUX® L 36 W lamp, for example, is around 150 K lower than that of an undimmed lamp. The colour difference appears greater to the eye because of the considerable difference in luminance. Even greater differences may occur temporarily if there is a sharp change in the dimmer setting (see 4.7 and 5.1.4).

#### **Ageing**

Generally speaking, there are no changes in colour temperature or shifts in chromaticity coordinates in the course of a lamp's service life. However, lamps do suffer a drop in luminous flux as they age (see 2.4) and it is the resulting difference in luminance between an old lamp and a new lamp that give the impression of a change in colour temperature.

**2.3.6 Spectral distribution**

The relative spectral power distribution is determined mainly by the light colour, whereas the different models and wattages have a negligible effect.

The spectral distributions shown below are therefore typical of all OSRAM DULUX® lamps for the relevant light colour.

y axis: mW/(m² x 5 nm x 1000 lx)  
 x axis: wavelength in nanometres

Notes on the charts:

The spectral irradiance distributions refer to an illuminance of 1000 lx. The advantage here is that the absolute values of any illuminance can be found simply by dividing by 1000 lx:

$$\frac{\text{Illuminance E (measured)} \times (\text{y-axis value})}{1000 \text{ lx}}$$

The spectral intensities are condensed into wavelength ranges of 5 nanometres. In other words, irrespective of the actual distributions, the values given have been integrated over 5 nm. This corresponds to the standard applied to all calculations of consequential results (such as colour and colour rendering).

The spectral power distribution of OSRAM DULUX LUMILUX® and LUMILUX® DE LUXE lamps can be found in the latest edition of the Lighting Programme.

**Light colours**

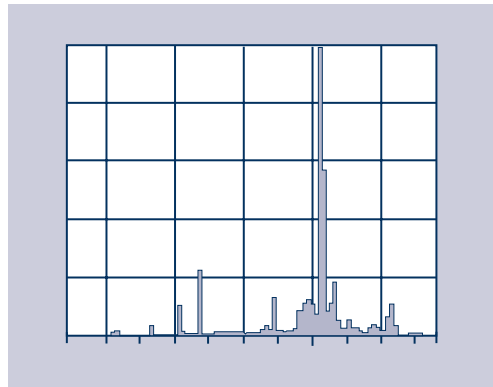

Colour 60 – Red

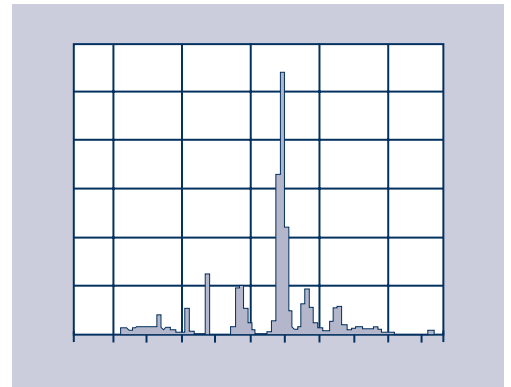

Colour 66 – Green

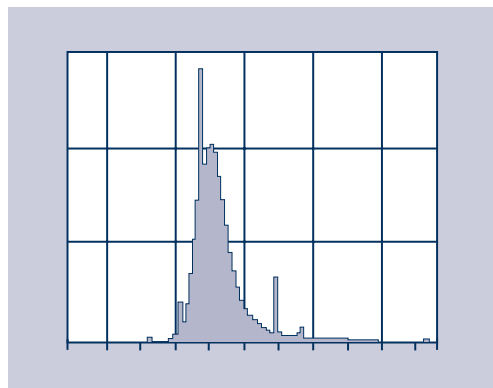

Colour 67 – Blue



### 2.3.7 Radiation components in the ultra-violet range

Ultra-violet radiation can have desirable effects (such as tanning) and undesirable effects (such as sunburn) on the human body. The intensity of these effects depends on the irradiance level and the period of exposure.

In the case of lamps intended for general lighting applications, lamp and luminaire manufacturers must ensure that there is no possibility of any harmful effects even under high illuminance levels over a full day.

The table shows that OSRAM DULUX® lamps meet this requirement without the need for any additional protective measures.

If light-sensitive materials are exposed to this light for relatively long periods, there may be some change in colour (bleaching, for example). In OSRAM DULUX® lamps this effect is caused primarily by UV-A radiation. Lamps with low UV-A components or low illuminance levels should therefore be chosen for illuminating light-sensitive materials.

UV components of OSRAM DULUX® light colours, referred to 1000 lux

Light colour		315-400nm UV-A	Ery- thema threshold*)	Pigmen- tation- threshold*)
No.	Type	mW/m <sup>2</sup>	h	h
<b>LUMILUX®</b>				
860	LUMILUX® Daylight	60,8	± 2500	400
840	LUMILUX® Cool white	60,8	± 2500	400
830	LUMILUX® Warm white	60,8	± 2500	400
827	LUMILUX INTERNA®	60,8	± 2500	400
<b>LUMILUX® DE LUXE</b>				
950	LUMILUX® DE LUXE Daylight	60,8	± 2500	400
940	LUMILUX® DE LUXE Cool white	60,8	± 2500	400
930	LUMILUX® DE LUXE Warm white	60,8	± 2500	400

\*) Exposure time after which at 1000 lux the first effects of reddening or tanning of the skin are noticeable (calculated according to DIN 5031/10).

### 2.3.8 Radiation components in the infra-red range

Fluorescent lamps emit radiation at wavelengths which are also used for infra-red transmissions. Since the IR receivers used for televisions, wireless headphones and sound transmission systems, for example, are often not sufficiently selective there may be interference in the IR system, particularly with lamps operated by electronic control gear, if light or optical radiation from the lighting system enters the IR receiver. The light emitted by a fluorescent lamp is essentially modulated at twice the operating frequency (50 to 250 kHz in the case of electronic control gear and 100 or 120 Hz in the case of conventional control gear). Interference may occur if the useful signal is also operating in this frequency range.

#### Audio transmission

For further information on this topic please consult the OSRAM QUICKTRONIC® technical guides or visit [www.osram.com](http://www.osram.com).

#### IR remote control

Interference-free operation is possible with systems that work with a sufficiently high carrier frequency (400 to 1500 kHz). If interference occurs in systems or equipment operating at a lower carrier frequency, it is best to move the IR receiver as far as possible away from the radiation footprint of the lamp or shield it from direct light.

For further information on this topic please consult the OSRAM QUICKTRONIC® technical guides or visit [www.osram.com](http://www.osram.com).

#### Electronic merchandise security systems

In many shops nowadays, merchandise such as CDs and clothing is protected against theft by electronic security systems. These systems typically operate with resonances in the kHz range. If the operating frequency is between 30 kHz and 150 kHz it may lead to interference. Such interference can be avoided by increasing the distance between the luminaires and the transmitting/receiving system.

For further information on this topic please consult the OSRAM QUICKTRONIC® technical guides or visit [www.osram.com](http://www.osram.com).

Infra-red components radiated by compact fluorescent lamps as a percentage of power consumption:

IR-C (> 2700 nm)	IR-B (1400 - 2700 nm)	IR-A (780 - 1400 nm)
38 - 40 %	0.15 %	0.6 %

**2.3.9 Luminous intensity distribution curves**

The luminous intensity distributions of OSRAM DULUX® lamps depend on the plane in which measurements are taken. For assessment and planning purposes, it is therefore not sufficient simply to consider the average of all planes. Measurements of the luminous intensity distribution in three selected planes are adequate.

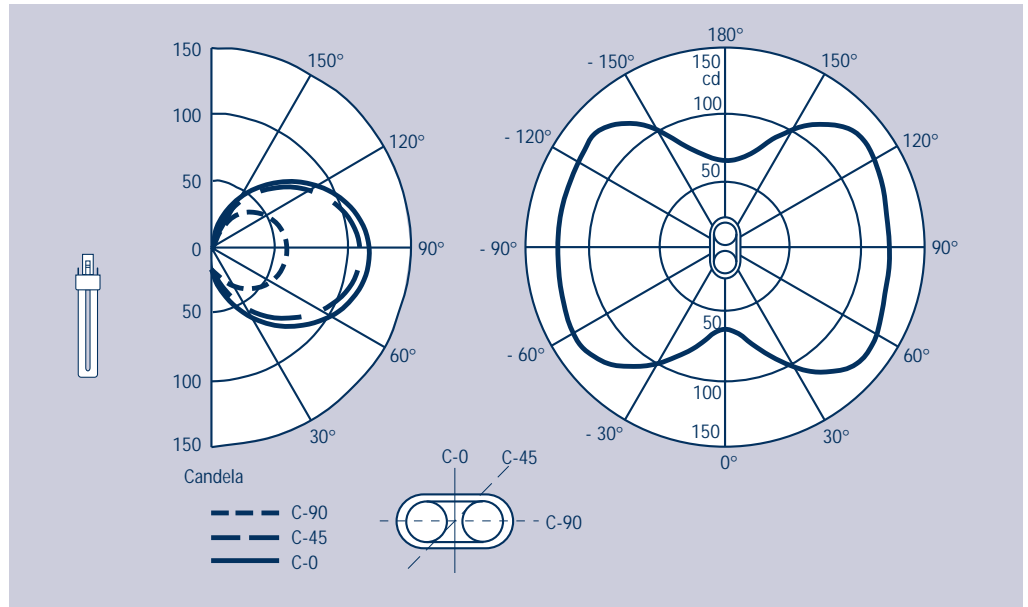

OSRAM DULUX® S, OSRAM DULUX® S/E, OSRAM DULUX® L  
 Axial and radial luminous intensity distribution referred to 1000 lm  
 Base-up position

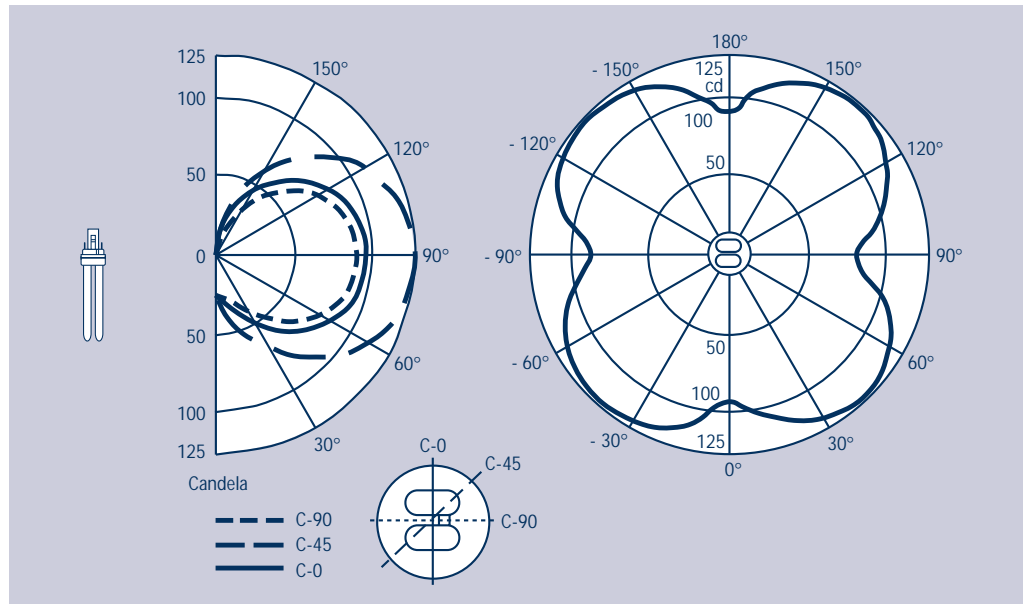

OSRAM DULUX® D, OSRAM DULUX® D/E  
 Axial and radial luminous intensity distribution referred to 1000 lm  
 Base-up position



2.3.9 Luminous intensity distribution curves (continued)

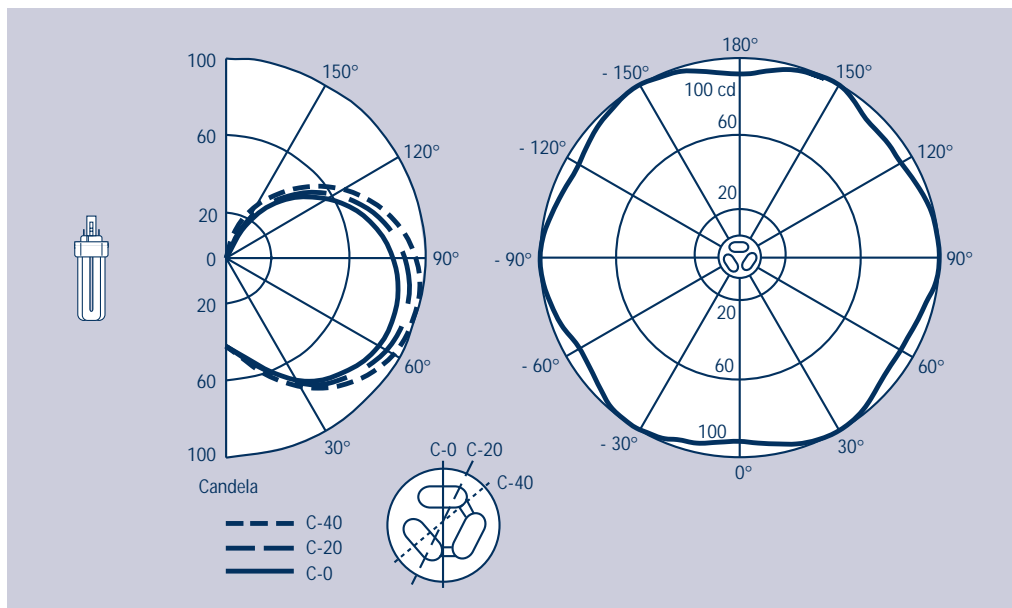

OSRAM DULUX® T, OSRAM DULUX® T/E  
 Axial and radial luminous intensity distribution referred to 1000 lm  
 Base-up position

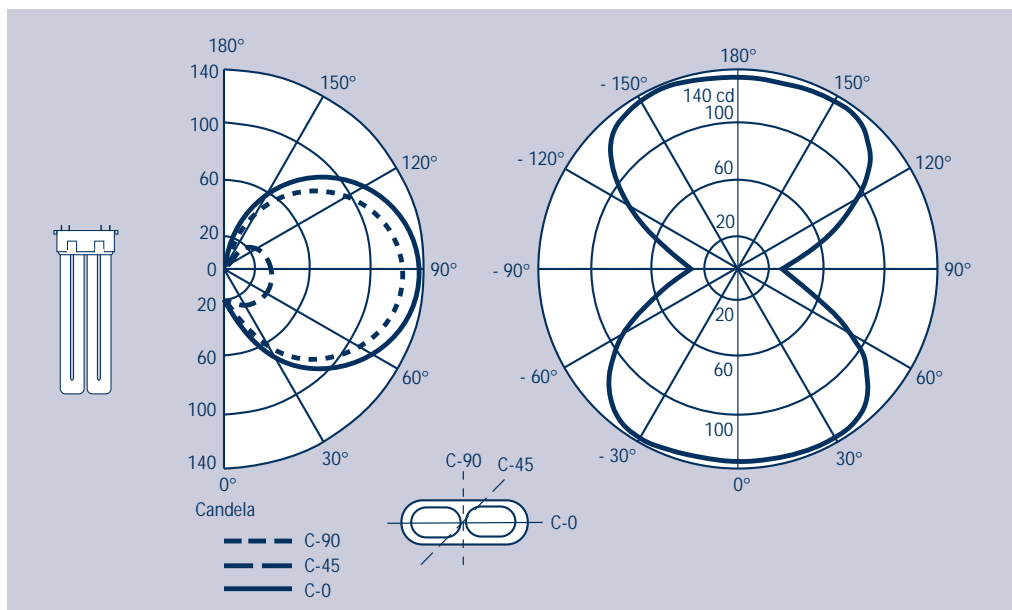

OSRAM DULUX® F  
 Axial and radial luminous intensity distribution referred to 1000 lm  
 Base-up position

**2.3.10 Luminance of OSRAM DULUX® lamps**

The luminance values shown in the following table are reference values only:

Lamp	Average luminance <sup>1)</sup> cd/cm <sup>2</sup>
OSRAM DULUX® S and S/E 5W	2.5
OSRAM DULUX® S and S/E 7W	2.6
OSRAM DULUX® S and S/E 9W	2.8
OSRAM DULUX® S and S/E 11W	2.7
OSRAM DULUX® D and D/E 10W	4.0
OSRAM DULUX® D and D/E 13W	4.0
OSRAM DULUX® D and D/E 18W	4.5
OSRAM DULUX® D and D/E 26W	5.5
OSRAM DULUX® T and T/E 13W	4.2
OSRAM DULUX® T and T/E 18W <sup>2)</sup>	4.7
OSRAM DULUX® T and T/E 26W <sup>2)</sup>	6.0
OSRAM DULUX® T/E 32W <sup>2)</sup>	6.5
OSRAM DULUX® T/E 42W <sup>2)</sup>	7.0
OSRAM DULUX® T/E 57W IN	7.0
OSRAM DULUX® T/E 70W IN <sup>3)</sup>	7.0
OSRAM DULUX® L 18W	2.1
OSRAM DULUX® L 24W	2.1
OSRAM DULUX® L 36W	2.8
OSRAM DULUX® L 40W	2.3
OSRAM DULUX® L 55W	3.2
OSRAM DULUX® L 80W	3.2
OSRAM DULUX® F 18W	2.4
OSRAM DULUX® F 24W	2.5
OSRAM DULUX® F 36W	3.0

<sup>1)</sup> For colours 840 LUMILUX® Cool White, 830 LUMILUX® Warm White and 827 LUMILUX INTERNA®

<sup>2)</sup> Also for „IN“ models

## 2.4 Lamp life and loss of luminous flux

### 2.4.1 Definitions

There are several definitions of lamp life and these are applied differently depending on the type of lamp, the lamp manufacturer and the geographical region. The most important definitions for compact fluorescent lamps are given below.

**Lamp life** is the period of time during which a lamp can be operated until it is unusable (electrical failure, too little light).

**Average rated lamp life** is the average value of the life values of individual lamps operated under standardised conditions (50 % failure). In other words, this is the period of time in which for a standardised 3-hour switching cycle (165 minutes on/15 minutes off in accordance with IEC 60901) 50 % of the lamps fail.

OSRAM DULUX® lamps	Average rated lamp life
OSRAM DULUX® S, D and T,	8.000 h
OSRAM DULUX® S/E, D/E and T/E with CCG	
OSRAM DULUX® S/E, D/E and T/E with ECG	10.000 h
OSRAM DULUX® L and F with CCG	8.000 h
OSRAM DULUX® L and F with ECG	10.000 h

Typical failure distributions are shown in **mortality curves**.

Because of chemical changes in the phosphor, the luminous flux of a fluorescent lamp decreases as the lamp ages. The term „**maintenance**“ is used to indicate how well luminous flux is retained throughout the life of the lamp. The loss of luminous flux for the trichrome phosphors (LUMILUX®) used in OSRAM DULUX® lamps is around 15 %.

The mortality and luminous flux curves for OSRAM DULUX® lamps are shown on the following pages.



2.4.2 Maintenance, loss of luminous flux for OSRAM DULUX® lamps

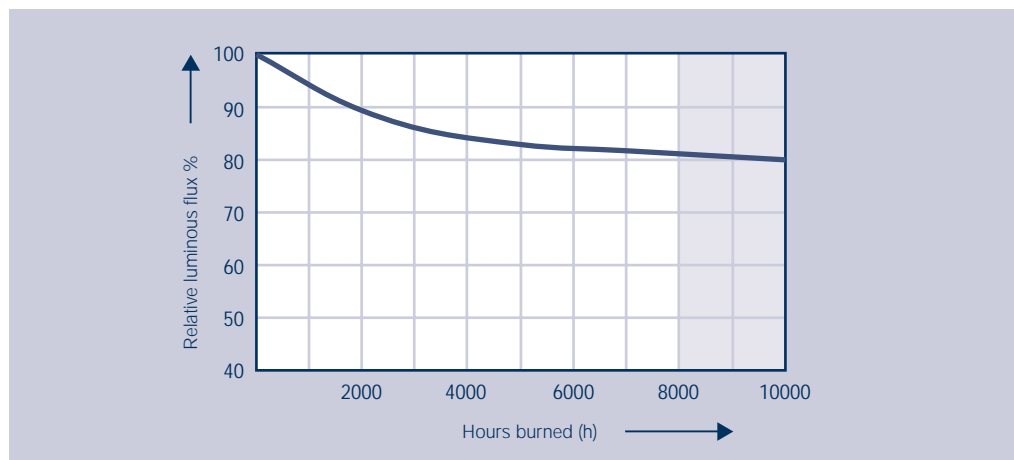

Relationship between luminous flux and hours burned (maintenance) for CCG operation

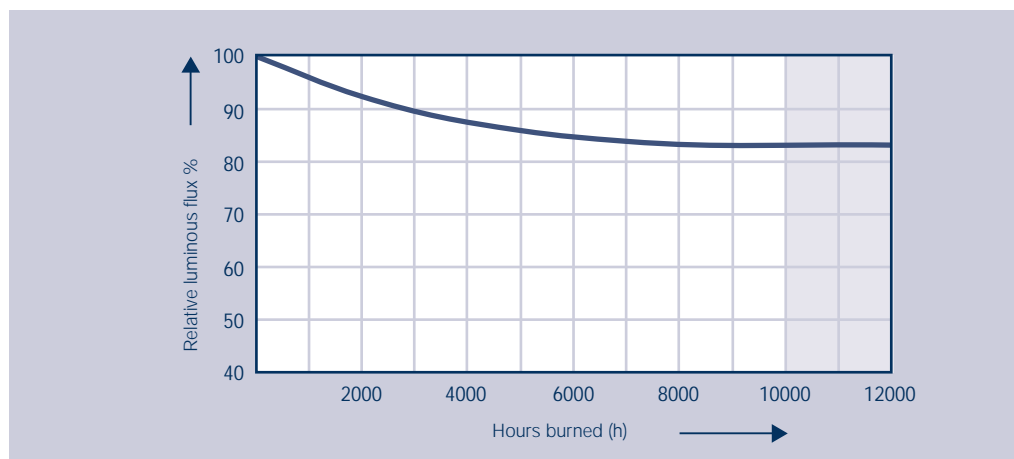

Relationship between luminous flux and hours burned (maintenance) for ECG operation

The curves shown here are the result of a large number of investigations under controlled and constant laboratory conditions. In actual practice, individual lamps or groups of lamps may deviate from these values.

A 3-hour switching cycle is used (165 minutes on / 15 minutes off).  
 The initial value for luminous flux corresponds to the 100 h value.

OSRAM DULUX® L 40, 55 and 80 W and OSRAM DULUX® T/E and T/E IN 32 to 70 W may only be operated on ECGs.

### 2.4.3 Mortality curves of OSRAM DULUX® lamps

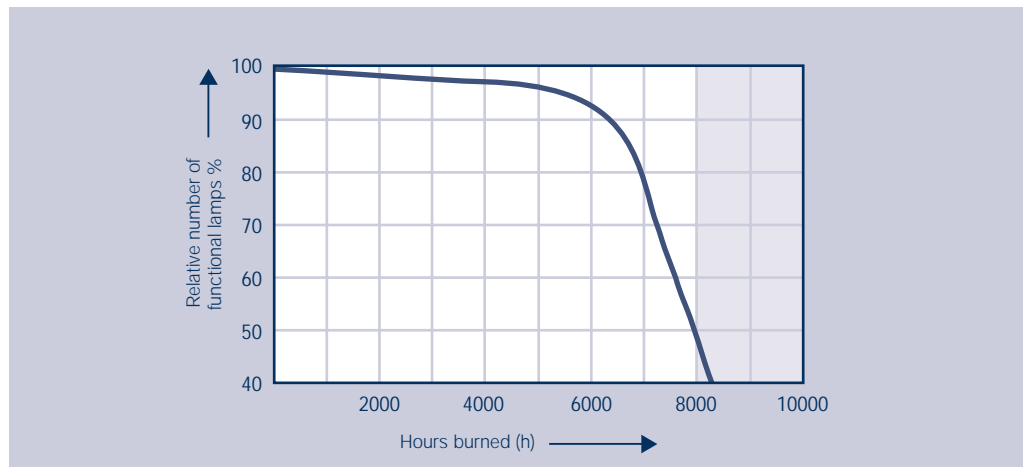

Typical mortality curve for CCG operation

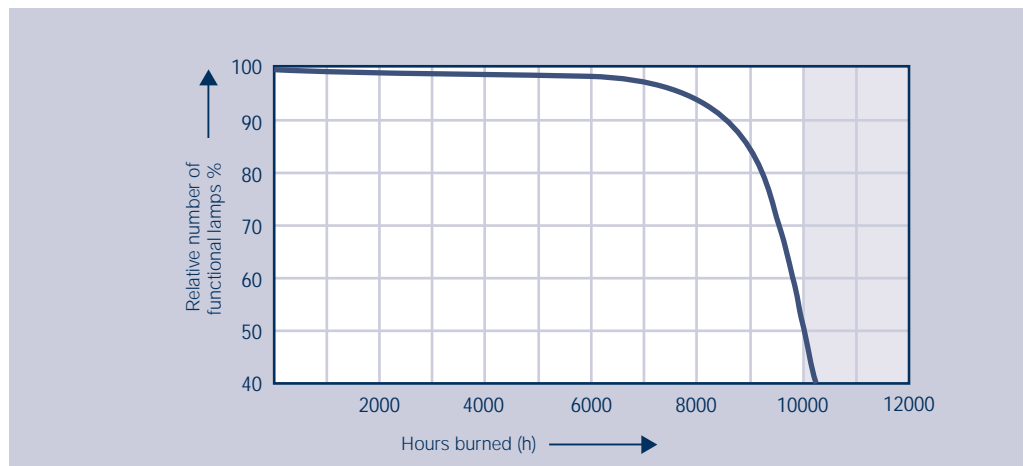

Typical mortality curve for ECG operation

The curves shown here are the result of a large number of investigations under controlled and constant laboratory conditions. In actual practice, individual lamps or groups of lamps may deviate from these values.

A 3-hour switching cycle is used (165 minutes on / 5 minutes off).  
The initial value for luminous flux corresponds to the 100 h value.

OSRAM DULUX® L 40, 55 and 80 W and OSRAM DULUX® T/E and T/E IN 32 to 70 W may only be operated on ECGs.

#### 2.4.4 Effect of switching operations on lamp life

Average rated lamp life is based on a switching cycle of 165 minutes on and 15 minutes off in accordance with IEC 60901. If there are fewer switching operations than under these standard conditions, average rated lamp life will be increased. If, however, the lamp is switched on and off more than this, it will not last as long.

If an electronic control gear designed for pre heat start is used, the number of possible switching operations is greatly increased against operation with a CCG thanks to optimum warm starting of the lamp.

The typical failure curves below show the basic relationship between the number of switching cycles and lamp life under rated conditions.

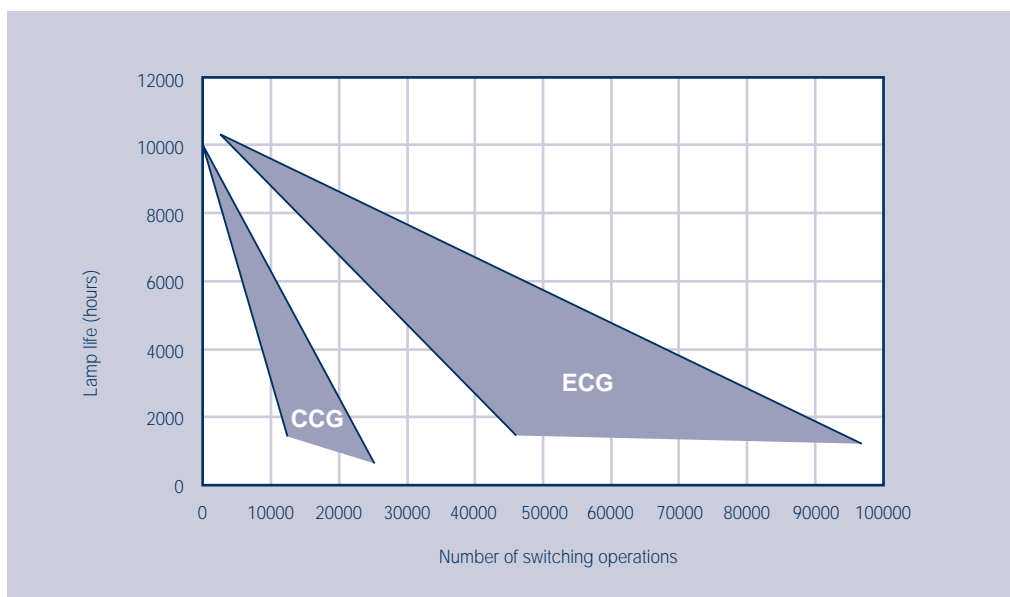

After the lamps have been switched off it is necessary to wait a certain time, depending on the type of equipment (see ECG specifications), to ensure optimum warm restart (essential for maximum lamp life).

### 3 Circuits

#### 3.1 Operation with electronic control gear (ECG)

OSRAM DULUX® S/E, D/E and T/E lamps and OSRAM DULUX® L 40, 55 W and 80 W lamps with four-pin bases have been designed to operate with electronic control gear only. OSRAM DULUX® L and F 18, 24 and 36 W can be operated with either electronic or conventional control gear.

To ensure safe operation of both the lamp and the ECG, the wiring between the outputs of the ECG and the terminals on the lampholder(s) must be correct. This applies not only to two-lamp arrangements but also to single-lamp configurations. Certain cables from the ECG to the lamp or lamps („hot ends“) should be kept as short as possible to avoid problems with radio interference. This means one should choose an asymmetrical mounting location in the luminaire to increase the length of the low-potential cables if you can thereby shorten the lamp cables carrying high potential. The correct circuit layout is generally printed on the ECG casing. Check with the ECG manufacturer to establish which terminals are the „hot ends“. This information may be shown on the casing (e.g. „keep wires x and y short“).

With dimmable ECGs the length of the control cable(s) and the way in which they are laid also play a role. For further information on this topic please consult the OSRAM QUICKTRONIC® technical guides or visit [www.osram.com](http://www.osram.com).

Another important factor with ECGs is the  $t_c$  measuring point on the casing. The temperature indicated here must not be exceeded during operation otherwise the unit will fail prematurely.

A prominent characteristic of electronic control gear, and one that applies to most units (see information on the casing) is whether or not it is suitable for dc operation (for approximately the same rms values for AC and DC). In many cases, a DC-compatible ECG can also be used in emergency lighting systems. The relevant regulations governing emergency lighting must be observed. QUICKTRONIC® control gear from OSRAM is suitable for emergency lighting in accordance with VDE 0108.

Information from the manufacturers regarding circuits (circuit diagrams) can generally be found on the casing cover.

For further information on permissible lamp/ECG combinations and system data please consult the latest edition of the OSRAM Lighting Programme or visit [www.osram.com](http://www.osram.com).

#### 3.2 Operation with conventional control gear (CCG)

OSRAM DULUX® S, D and T lamps with a two-pin base have an integrated glow starter and are suitable for CCG operation. OSRAM DULUX® L and F lamps with four-pin bases do not have an integrated glow starter and require an external starter (see 6.3) if they are to be operated with conventional control gear (18 W to 36 W). It is recommended that only suitable lamp/CCG combinations for single and series circuits be used. The system data (lamp + CCG) is shown in the table in 3.2.1.

Circuit diagrams are included in the current OSRAM Lighting Programme.

**Compact Fluorescent Lamps OSRAM DULUX®**

Technical Guide

**3.2.1 Permissible lamp/  
CCG combinations  
and system data**

OSRAM DULUX® lamps should be operated only with suitable control gear. If the control gear has a too high rating the lamps will be overloaded by an excessively high current, which may shorten their life and an overheating of the lamp cap. If, however, the gear has too low a rating the lamps will not be supplied with enough current; this may damage the lamp and therefore again shorten its life. Normally, if the lamps are underloaded in this way, the glow starter will also be made to operate as a result of excessive increase in lamp voltage.

The following table provides a summary of suitable conventional control gear, together with system data.

Lamp	CCG	Lumi- nous flux lm	Sys- tem loss <sup>1)</sup> W	System wattage W	System luminous efficacy lm/W
OSRAM DULUX® S 5 W	5-11W / KLL (155-180 mA)	250	4.5	9.9	25
OSRAM DULUX® S 7 W	5-11W / KLL (155-180 mA)	400	4.0	11.1	36
OSRAM DULUX® S 9 W	5-11W / KLL (155-180 mA)	600	4.0	12.7	47
OSRAM DULUX® S 11 W	5-11W / KLL (155-180 mA)	900	3.5	15.3	59
2x OSRAM DULUX® S 5 W	10-13W / KLL (165-180 mA) <sup>2)</sup>	500	5.0	15.8	32
2x OSRAM DULUX® S 7 W	10-13W / KLL (165-180 mA) <sup>2)</sup>	800	4.0	18.2	44
2x OSRAM DULUX® S 9 W	10-13W / KLL (165-180 mA) <sup>2)</sup>	950	5.0	22.4	42
OSRAM DULUX® D 10 W	10-13W / KLL (165-180 mA)	600	5.0	15.0	40
OSRAM DULUX® D 13 W	10-13W / KLL (165-180 mA)	900	4.0	17.0	53
OSRAM DULUX® D 18 W	18W / KLL (220 mA)	1200	5.0	23.0	52
OSRAM DULUX® D 26 W	24-26W / KLL (315 mA) also 18W/LLp (370 mA) <sup>3)</sup>	1800 1800	4.5	30.5	59
OSRAM DULUX® T 13 W	10-13W / KLL (165-180 mA)	900	4.0	17.0	53
OSRAM DULUX® T 18 W (IN)	18W / KLL (220 mA)	1200	5.0	23.0	52
OSRAM DULUX® T 26 W (IN)	24-26W / KLL (315 mA) also 18W/LLp (370 mA) <sup>3)</sup>	1800 1800	4.5	31.0	58
OSRAM DULUX® L 18 W	18W / LLp (370 mA)	1200	6.0	24.0	50
OSRAM DULUX® L 24 W	24-26W/KLL (315 mA) also 18W / LLp (370 mA) <sup>3)</sup>	1800 1800	5.5	29.5	61
OSRAM DULUX® L 36 W	36W / LLp (430 mA)	2900	6.5	42.5	68
2 x OSRAM DULUX® L 18 W	36W / LLp (430 mA) <sup>3)</sup>	2500	6.5	42.5	59
OSRAM DULUX® F 18 W	18W / LLp (370 mA)	1100	6.0	24.0	46
OSRAM DULUX® F 24 W	24-26W / KLL (315 mA) also 18W / LLp (370 mA) <sup>3)</sup>	1700 1700	5.0	29.0	59
OSRAM DULUX® F 36 W	36W / LLp (430 mA)	2800	6.5	42.5	66
2 x OSRAM DULUX® F 18 W	36W / LLp (430 mA) <sup>3)</sup>	2300	6.0	42.0	55

<sup>1)</sup> Approximate values for low-loss gear, depending on the particular unit

<sup>2)</sup> While **2 x OSRAM DULUX® 5 W** and **7 W** can be operated in series with suitable control gear on 200 V and higher, a supply voltage of at least 220 V is needed for **2 x OSRAM DULUX® 9 W** in series.

Conventional control gear for L 13 W can also be used for **2 x OSRAM DULUX® 5 W**, **2 x 7 W** and **2 x 9 W** in series provided a preheating current of 240 mA is maintained under limit conditions.

Control gear for series circuits must not be used for **OSRAM DULUX® S** lamps in single circuits.

<sup>3)</sup> With this combination, however, there are considerable restrictions regarding the life of the lamps.

It is not possible to connect **2 x OSRAM DULUX® D** or **OSRAM DULUX® T** in series using a choke. It is not possible to connect **2 x OSRAM DULUX® S 11 W**, **2 x OSRAM DULUX® L** and **F 24 W** and **36 W** in series because the arc voltage is too high.

### 3.2.2 Compensation

The need to compensate for the reactive power depends on the technical connection conditions of the electricity supply company. Compensation for reactive power is covered by the EN 61000-3-2 standard (see 9.1.2). Compensation can be provided on an individual basis per luminaire, for groups of luminaires or at a central location. Generally, electricity consumption should involve a power factor of between  $\cos \varphi$  0,9 (capacitive) and 0,8 (inductive). Depending on the type of system, which obviously comprises more inductive loads than just low-voltage discharge lamps, one has to decide which type of compensation should be used:

- Individual compensation per luminaire
- Group compensation
- or central compensation.

The capacitor must be connected in parallel with the mains terminals. Compensation with a series capacitor is possible in certain circumstances but, except in the case of OSRAM DULUX® L 36 W, is not recommended since the permissible current and power limits cannot be reliably maintained if the permissible tolerances for the capacitors, control gear and lamps are fully utilised.

The limits for exploiting the permitted tolerances (close tolerance) for the capacitance of the series capacitor ( $\pm 2\%$ ) and the impedance of the choke ( $\pm 1,5\%$ ) or lamps cannot be reliably met.

Mains parallel capacitors are not permitted in existing audio-frequency remote control systems operating at high frequency. They are suitable only for compensation with series capacitors.

Compensation is not required if the lamps are operated with electronic control gear. The following table shows the capacitance values for the various lamps.

	Parallel compensation <sup>1)</sup> 230V/50Hz $\mu\text{F}$	Series compensation <sup>2)</sup> 230V/50Hz $\mu\text{F}$
OSRAM DULUX® S 5 W	2.2	-
OSRAM DULUX® S 7 W	2.1	-
OSRAM DULUX® S 9 W	2.0	-
OSRAM DULUX® S 11 W	1.7	-
2x OSRAM DULUX® S 5 W	1.9	-
2x OSRAM DULUX® S 7 W	1.6	-
2x OSRAM DULUX® S 9 W	1.2	-
OSRAM DULUX® D 10 W	2.2	-
OSRAM DULUX® D 13 W	1.8	-
OSRAM DULUX® D 18 W	2.2	1.7
OSRAM DULUX® D 26 W	3.2	2.5 <sup>3)</sup>
OSRAM DULUX® T 13 W	1.8	-
OSRAM DULUX® T 18 W (IN)	2.3	1.7
OSRAM DULUX® T 26 W (IN)	3.3	2.5 <sup>3)</sup>
OSRAM DULUX® L 18 W	4.2	2.7
OSRAM DULUX® L 24 W	3.6	2.7
OSRAM DULUX® L 36 W	4.4	3.4
2 x OSRAM DULUX® L 18 W	3.4	3.4
OSRAM DULUX® F 18 W	4.2	2.7
OSRAM DULUX® F 24 W	3.6	2.7
OSRAM DULUX® F 36 W	4.4	3.4
2 x OSRAM DULUX® F 18 W	3.4	3.4

<sup>1)</sup> For  $\cos \phi = 0,95$ ; Dielectric strength of the capacitors 250 V ac; Capacitance tolerance  $\pm 10\%$

<sup>2)</sup> For  $\cos \phi =$  at least 0,95; Dielectric strength of the capacitors 450 V ac  
 To guarantee the prescribed operating and preheating values, capacitors and control gear with narrow tolerances ( $\pm 2\%$  and  $\pm 1,5\%$  respectively) are needed for series compensation. Please refer to the catalogues of the major manufacturers.

<sup>3)</sup> 24-26 W CCG for CFLs (2,7 $\mu\text{F}$  for 18 W CCG for fluorescent lamp).



## Compact Fluorescent Lamps OSRAM DULUX®

Technical Guide

### 3.2.3 Operation of OSRAM DULUX® S/E, D/E and T/E with external starter and CCG

OSRAM DULUX® S, D and T lamps (with two-pin bases) have been designed specifically for operation with conventional control gear. Integrated in their bases is a specially developed glow starter that has been adapted to the particular requirements of these compact fluorescent lamps. OSRAM DULUX® S/E, D/E and T/E with four-pin bases are intended for operation with electronic control gear, and hence without a starter. Generally, it is possible to operate OSRAM DULUX® S/E, D/E and T/E lamps (13 W, 18 W and 26 W only) with conventional control gear and an external starter under normal operating conditions. However, there is no starter currently available on the market that has been designed specifically for this purpose (see also 6.3).

**In this mode, considerable limitations can therefore be expected, such as greatly reduced lamp life with lamp glass blackening on the electrode side and longer ignition times. For this reason, this mode of operation is not recommended or supported by OSRAM.**

OSRAM DULUX® T/E 32 W, 42 W, 57 W and 70 W lamps and OSRAM DULUX® L 40, 55 and 80 W lamps are approved only for ECG operation owing to their high arc voltages.

**Compact Fluorescent Lamps OSRAM DULUX®**

Technical Guide

**3.3 Operating on dc sources****Compact fluorescent lamps cannot be operated from DC sources with conventional control gear.**

Most ECGs are DC-compatible. The dc voltage must be around the rated mains voltage of 230 V. See information supplied by ECG manufacturers.

Special ECGs such as OSRAM ACCUTRONIC® are available which allow OSRAM DULUX® S/E, D/E, T/E, L and F lamps to be operated from DC sources which do not correspond to rated mains voltages (such as the 12 V, 24 V or 48 V sources found in emergency lighting systems, vehicles and caravans).

In these cases, power is supplied by a battery or batteries. In continuous operation, the dc voltage must not drop below 11 V (AT 7-9/12 L) or 23 V (AT 7-9/24 L) otherwise the lamps will be constantly operating in underload mode. This will damage the lamp electrodes (sputter effect at the electrode).

Manufacturers of suitable control gear for different lamp wattages and battery voltages are listed in 10.2 and 10.3.

Changeover units (emergency luminaires with internal changeovers, known as battery packs) are offered. These feed the lamps directly on emergency power supply and interrupt the system circuit between the CCG or ECG and the lamps. These changeover units for emergency lighting must reliably comply with the parameters for preheating and for operating the lamps. If operated continuously, control gear for emergency lighting can generate a dc component that may damage the lamp electrodes (underload operation of the lamps). This underload operation with a DC component causes electrophoresis in the lamp. As a result, the mercury migrates from one electrode to another if the lamp is operated continuously. This greatly reduces the life of the lamp. In this case, OSRAM therefore cannot guarantee the life of the lamp.

**3.3.1 Suitable OSRAM ECGs for DC operation**

OSRAM offers the following ECGs under the ACCUTRONIC® name for dc operation. (See Lighting Programme).



---

**3.4 Operation with motion detectors and light sensors**

It is basically possible to operate OSRAM DULUX® compact fluorescent lamps with pin bases in conjunction with motion detectors and light sensors. Bear in mind that in these arrangements the lamps operate only for short periods before switching off again, so the run-up time for light output (the time the lamp takes to reach 100 % luminous flux) and the reduction in lamp life due to the high number of switching operations are factors that must be taken into account. (see 2.4.4)

CCG-operated lamps should not be used in applications with extremely frequent on/off switching. Instead, only compact fluorescent lamps for ECG operation should be used. The ECG should be selected to ensure optimum lamp starting every time.

Stand-by operating modes are ideal for such applications. In stand-by mode the light is dimmed when it is not needed. This avoids unnecessary switching operations and saves energy. Because the light is never fully switched off there is always a certain amount of light available for people to find their way around. Full light is available instantly, with no pre-heating delay. Typical applications for stand-by mode include all those with frequent on/off switching, such as stairwells, corridors and underground garages. Particularly if the light is controlled with motion detectors or time switches.

**3.5 Dimensioning of automatic circuit breakers**

Information on the maximum permitted number of luminaires per automatic circuit-breakers can be found in the OSRAM Lighting Programme.

## 4 Operating characteristics

### 4.1 Start-up characteristics

#### 4.1.1 Single circuit, inductive operation

For OSRAM DULUX® compact fluorescent lamps the average starting times in inductive mode are: 1.5 to 3.0 seconds for a supply voltage of 230 V and an ambient temperature of 25°C. At low temperatures and/or if the supply voltage falls 10 % below its rated value of 230 V there will be a considerable increase in the starting times.

OSRAM DULUX® T 18 and 26 W IN (amalgam lamps) should be ignited and operated only at the optimum supply voltage (230 V) and never below 5°C.

Type	Power	Average ignition time at the rated voltage 230 V (s)				Average ignition time at the rated voltage 230 V -10% (s)			
		25°C	0°C	-10°C	-20°C	25°C	0°C	-10°C	-20°C
OSRAM DULUX® S	5 W	2	2	2	2	2	2	2	2
	7 W	2	3	3	3	3	7	>10	>10
	9 W	1	3	>10	>10	2	3	>10	>10
OSRAM DULUX® D	11 W	2	2	2	5	4	4	4	6
	10 W	2	2	3	3	4	5	6	8
	13 W	2	2	2	-	3	6	4	-
	18 W	2	2	2	3	6	7	8	-
OSRAM DULUX® T	26 W	3	3	3	-	6	7	-	-
	13 W	3	>10	>10	>10	7	-	-	-
	18 W	2	>10	-	-	5	>10	-	-
OSRAM DULUX® T IN	26 W	2	3	>10	-	6	9	-	-
	18 W	*)	*)	*)	*)	>10	-	-	-
	26 W	3	12	-	-	>10	-	-	-
OSRAM DULUX® L	18 W	1	2	2	3	3	4	5	7
	24 W	2	4	5	6	5	7	10	>10
	36 W	3	4	4	5	5	8	8	-
OSRAM DULUX® L SP	18 W	*)	*)	*)	*)	*)	*)	*)	*)
	24 W	*)	*)	*)	*)	*)	*)	*)	*)
OSRAM DULUX® F	18 W	*)	*)	*)	*)	*)	*)	*)	*)
	24 W	*)	*)	*)	*)	*)	*)	*)	*)
	36 W	*)	*)	*)	*)	*)	*)	*)	*)

\*) In preparation

#### 4.1.2 Series circuit, inductive operation

The average starting times are also increased in the case of series circuits in inductive mode.

Amalgam lamps are not suitable for series circuits in inductive or capacitive operation.

**4.2 Starting at low temperatures**

Some of the models in the OSRAM DULUX® compact fluorescent lamp range are ideal for use in outdoor lighting systems where temperatures during the cold season may be 0°C or below. Some models ignite quite readily even at these low temperatures, and some have critical ignition limits. When selecting lamps and luminaires, therefore, the temperature factor should also be considered.

The following table shows the low temperature ranges at which various models with two-pin bases will still start reliably in conjunction with conventional control gear.

Operating conditions: 230 V/50 Hz supply voltage  
 Base-down position

Lamp	Reliable ignition at temperatures down to:							
	5°C	0°C	-5°C	-10°C	-15°C	-20°C	-25°C	-30°C
OSRAM DULUX® S		7 W, 9 W						5 W, 11 W
OSRAM DULUX® D		26 W		13 W, 18 W				10 W
OSRAM DULUX® T		13 W, 18 W, 26 W						
OSRAM DULUX® T IN 26 W		18 W						
OSRAM DULUX® L							36 W	18 W, 24 W
OSRAM DULUX® L SP								18 W, 24 W
OSRAM DULUX® F						36 W	18 W, 24 W	

With electronic control gear, the temperature range for reliable ignition is extended downwards, even for critical models. Irrespective of the ambient temperature, the lamp is always supplied with the optimum ignition pulse. Repeated attempts to ignite the lamp at low temperatures will damage the lamp. With ECGs this situation is avoided altogether. The temperature range in which an ECG will reliably ignite a lamp depends on the ECG itself. Consult the ECG manufacturer for more details. Depending on the particular lamp and the particular ECG used, OSRAM QUICKTRONIC® units can ignite compact fluorescent lamps at temperatures as low as -15°C or -20°C.

Reliable ignition (inductive operation) of the lamps (at low temperatures according to the above table) takes place at rated voltage within a period of 60 s. There is a chance that these ignition times will increase as the lamps age (ageing of the starters) or if moisture penetrates the luminaire. In capacitive operation a longer ignition time than with inductive operation must be expected.

In the case of inductive operation with undervoltage, the temperature threshold for reliable ignition of the lamps is raised. This longer ignition time must be taken into account.



**4.3 Run-up behaviour (Luminous flux)**

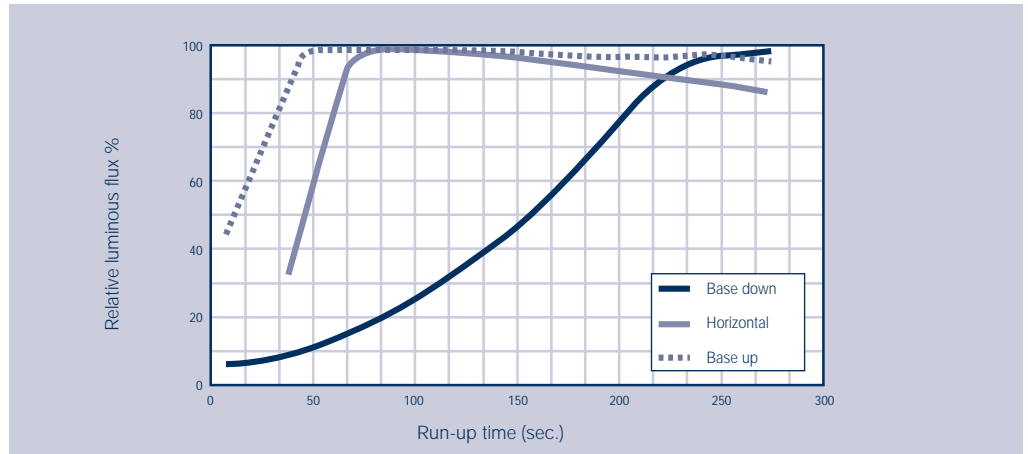

Typical run-up behaviour of OSRAM DULUX® lamps (except special models) in CCG operation, 25 °C ambient temperature, 230 V/50 Hz, free-burning

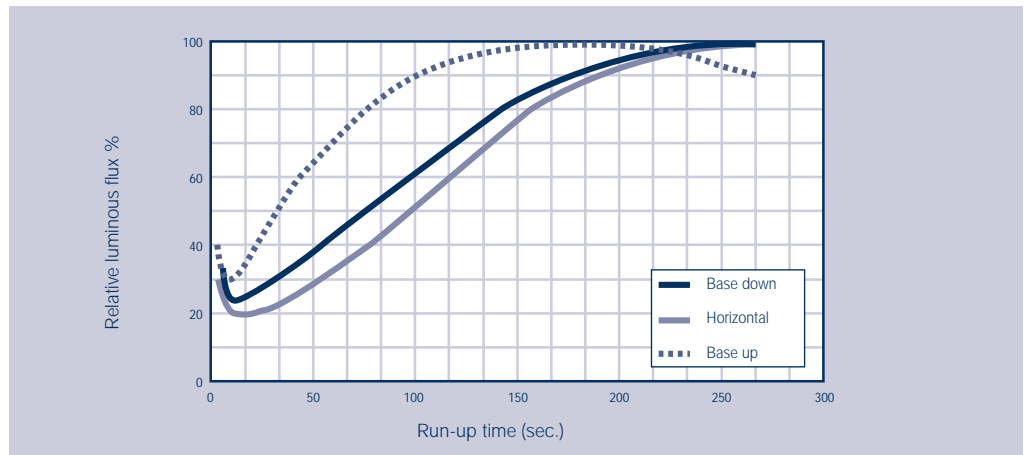

Typical run-up behaviour of OSRAM DULUX® lamps (except special models) in ECG operation, 25 °C ambient temperature, 230 V/50 Hz, free-burning

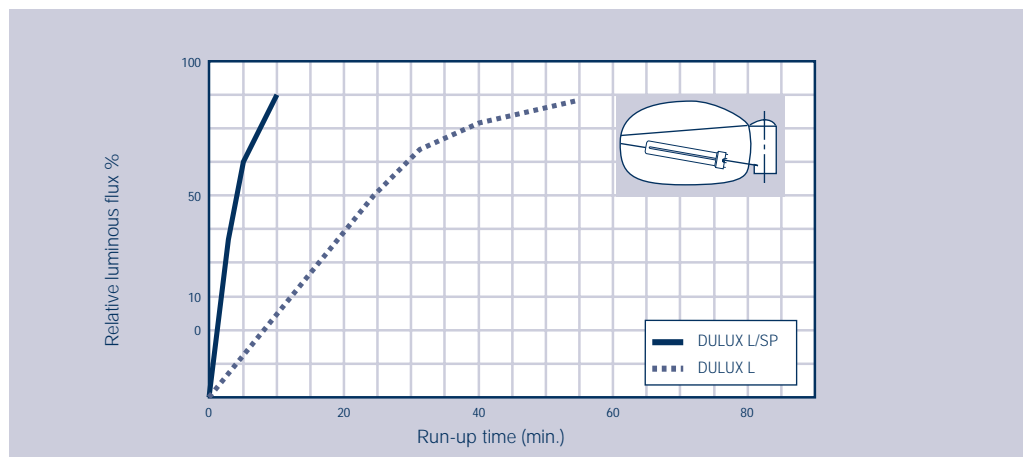

Typical run-up behaviour of OSRAM DULUX® L and L...SP lamps in a side surface-mounted luminaire until 90 % of the luminous flux is reached. The curves relate to a luminaire ambient temperature of -5 °C. Burning position of the lamps in the luminaire horizontal +9.5° angle.

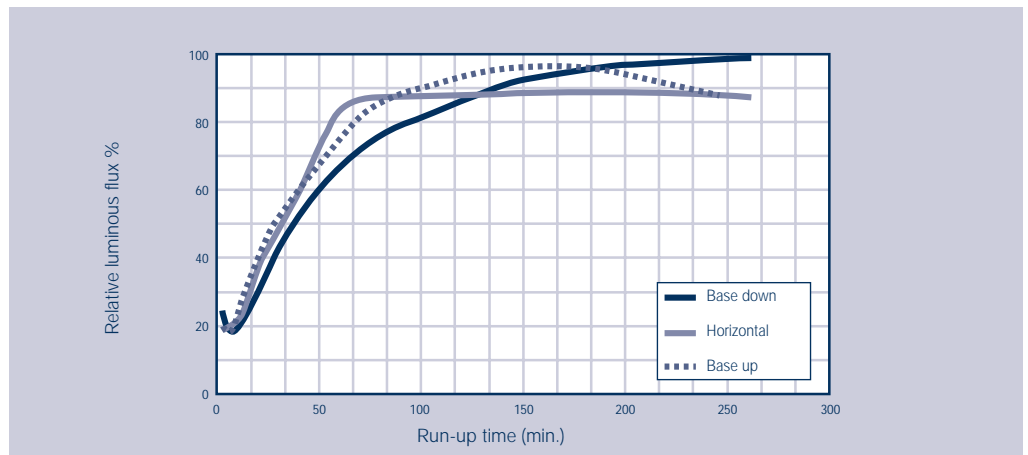

Typical run-up behaviour of OSRAM DULUX® T/E...IN (amalgam lamps) in ECG operation (long off time), 25 °C ambient temperature, 230 V/50 Hz, free-burning

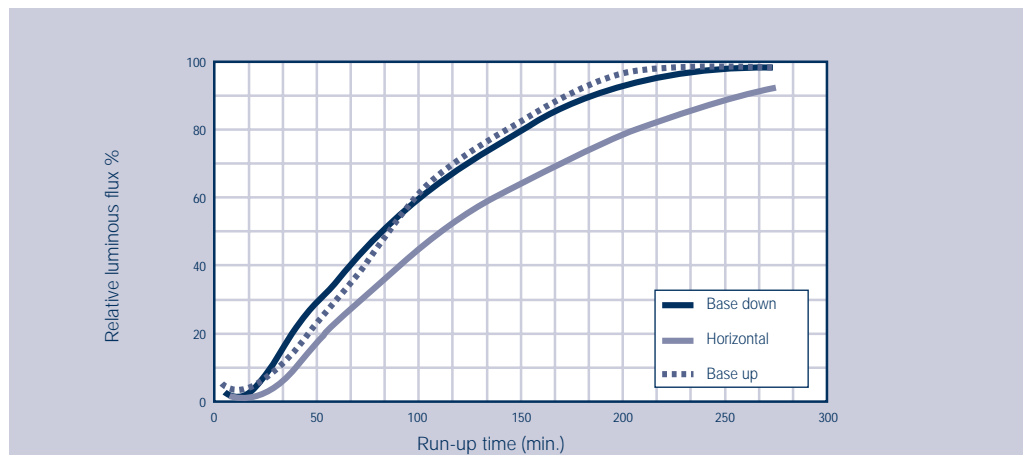

Typical run-up behaviour of OSRAM DULUX® T/E...IN (amalgam lamps) in ECG operation (short off time), 25 °C ambient temperature, 230 V/50 Hz, free-burning

4.4 Operating values of the lamps as a function of mains voltage

Burning position: Base up, free-burning  
 Ambient temperature: 25 °C

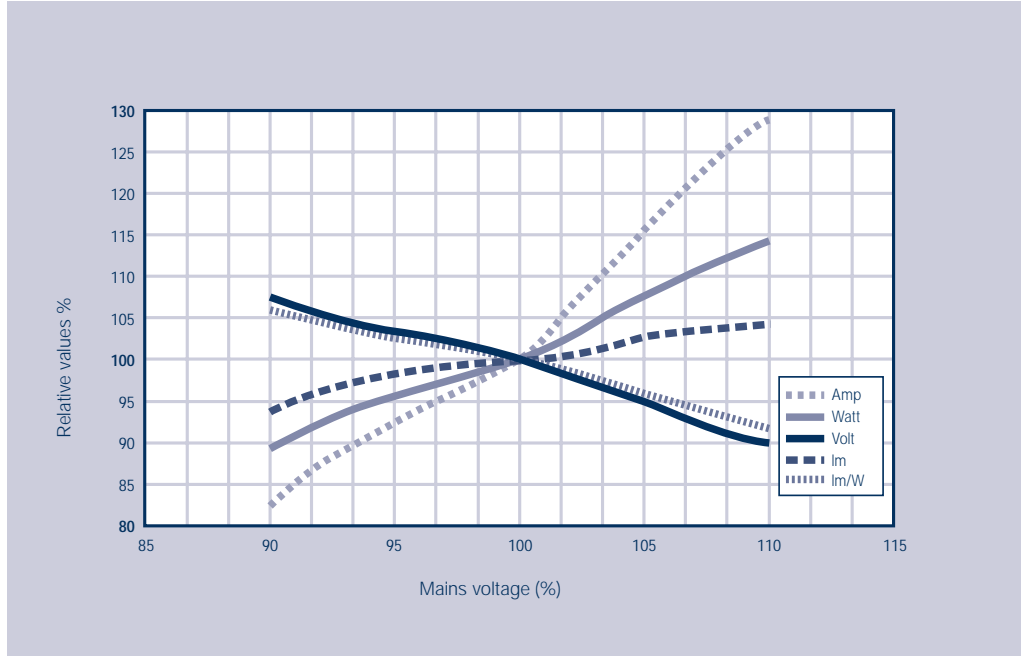

Typical curves for the electrical and photometric data as a function of mains voltage for OSRAM DULUX® lamps in CCG operation

Burning position: Base up, free-burning  
 Ambient temperature: 25 °C

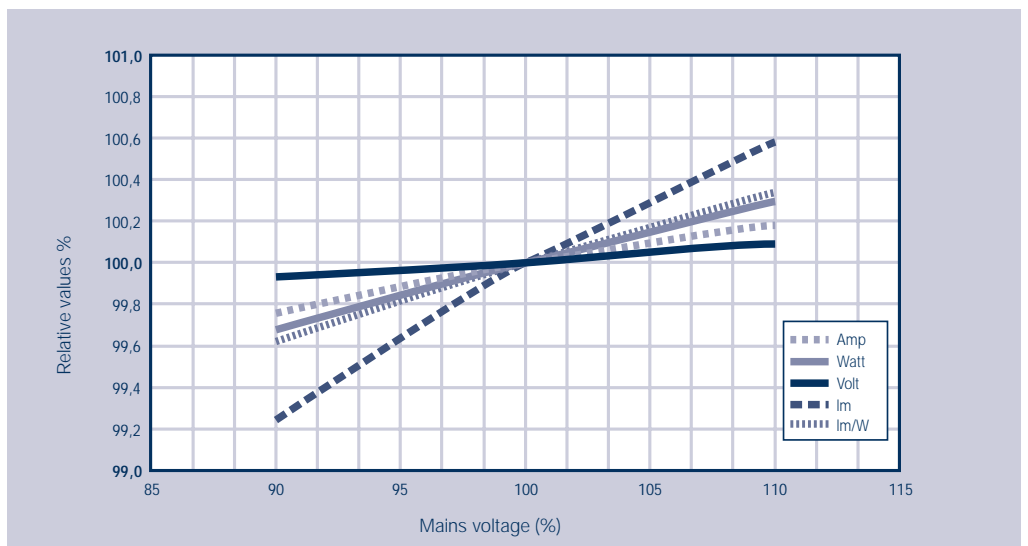

Typical curves for the electrical and photometric data as a function of mains voltage for OSRAM DULUX® lamps in ECG operation

**4.5 Operating values of the lamps as a function of ambient temperature**

Burning position: Base up, free-burning  
 Mains voltage: 230 V

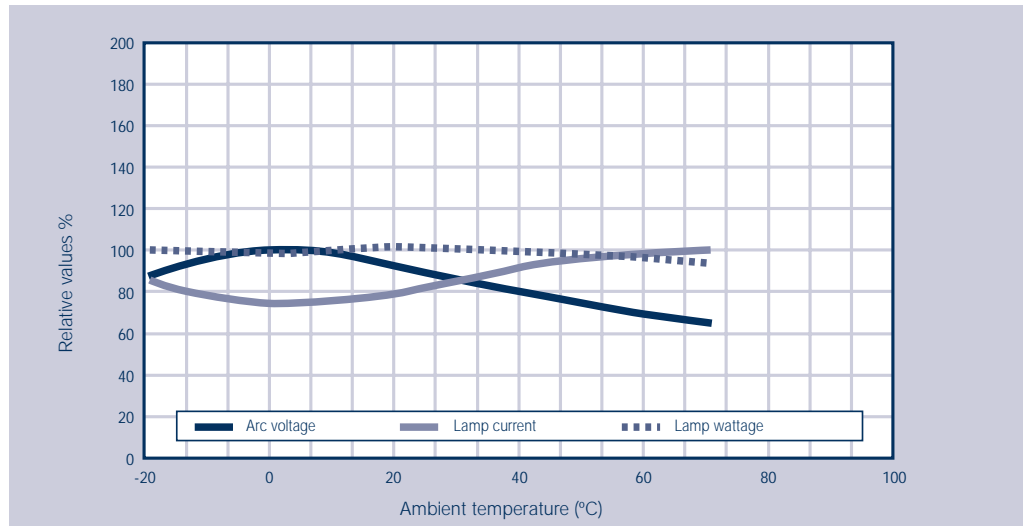

Typical curves for the electrical data as a function of ambient temperature for OSRAM DULUX® lamps in CCG operation

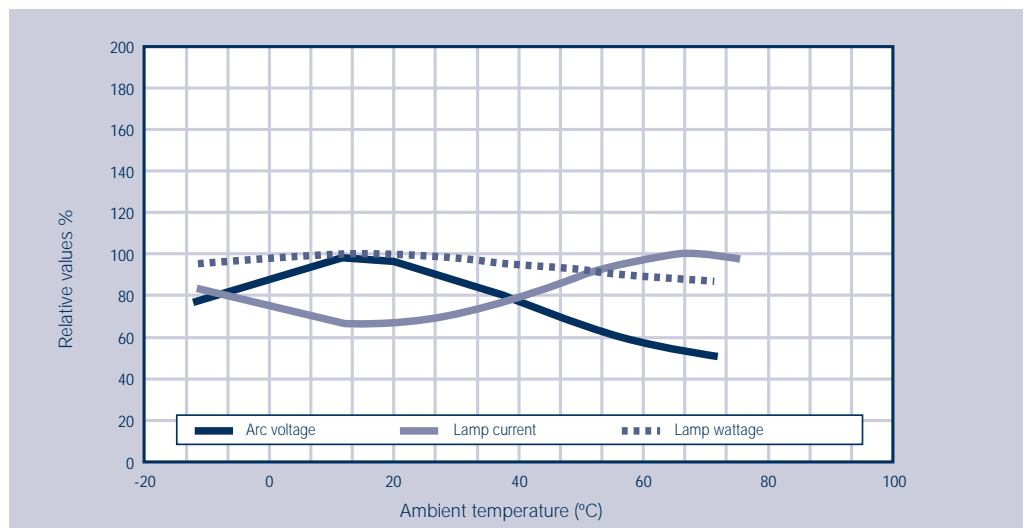

Typical curves for the electrical data as a function of ambient temperature for OSRAM DULUX® lamps in ECG operation

#### 4.6 Luminous flux as a function of temperature and burning position

OSRAM DULUX® lamps achieve 100 % luminous flux at ambient temperatures of 15 °C or 25 °C, depending on the burning position, only after a certain run-up time has elapsed, as the curves above show (see 4.3).

For free-burning lamps, the ambient temperature corresponds to the room temperature. If lamps are operated in luminaires, the temperature in the immediate vicinity of the lamp is the one that is relevant to any measurement of luminous flux.

The lamps can be operated in any burning position. However, different burning positions and different ambient temperatures will lead to different luminous flux values. This is due to temperature changes at certain locations on the lamp, known as the cold spots. For this reason, we talk about the cold spot temperature. This temperature affects the mercury vapour pressure in the lamp and therefore the luminous flux. A knowledge of the luminous flux/temperature curve is important for luminaire designers. The base-up position is favoured for indoor lighting, for example, whereas the base-down position is preferred for out-door lighting (compare the values at 0 °C, for example).

OSRAM DULUX® and OSRAM DULUX® IN lamps are optimised for various temperature ranges. OSRAM DULUX® IN amalgam lamps are ideal for high ambient temperatures and emit more than 90 % of their maximum luminous flux over a wide temperature range. If both types are used in a system with several luminaires there may, however, be differences in colour perception and brightness. For this reason the two types should not be used in combination.

Depending on the burning position the maximum luminous flux will be reached only after a certain Run-up time (see 4.3). Under optimum conditions in CCG and ECG operation, all the lamps require a burn-in time of 100 h (ageing).

##### 4.6.1 Luminous flux/temperature curves for OSRAM DULUX® lamps in general

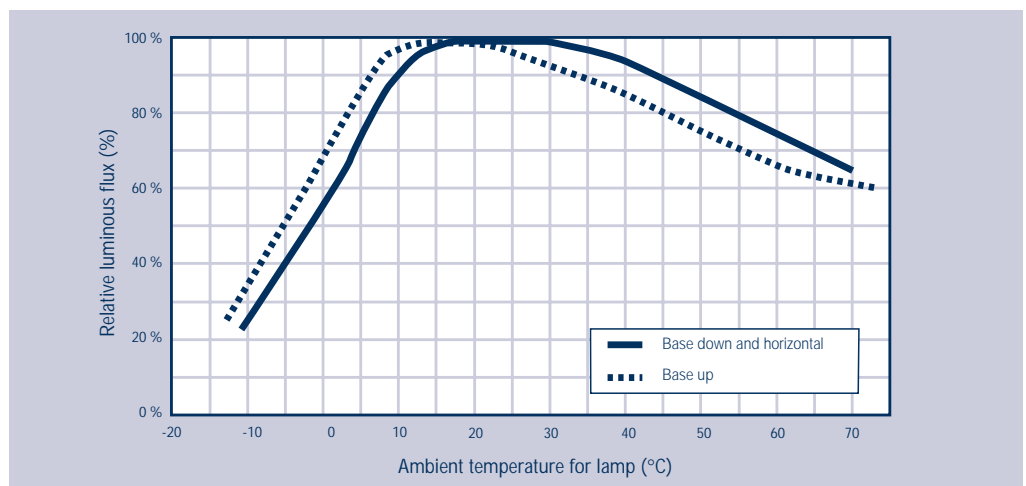

Typical luminous flux/temperature curves (here OSRAM DULUX® T/E).



**4.6.2 Luminous flux/  
 temperature curves  
 for OSRAM DULUX®  
 IN lamps for indoor  
 lighting**

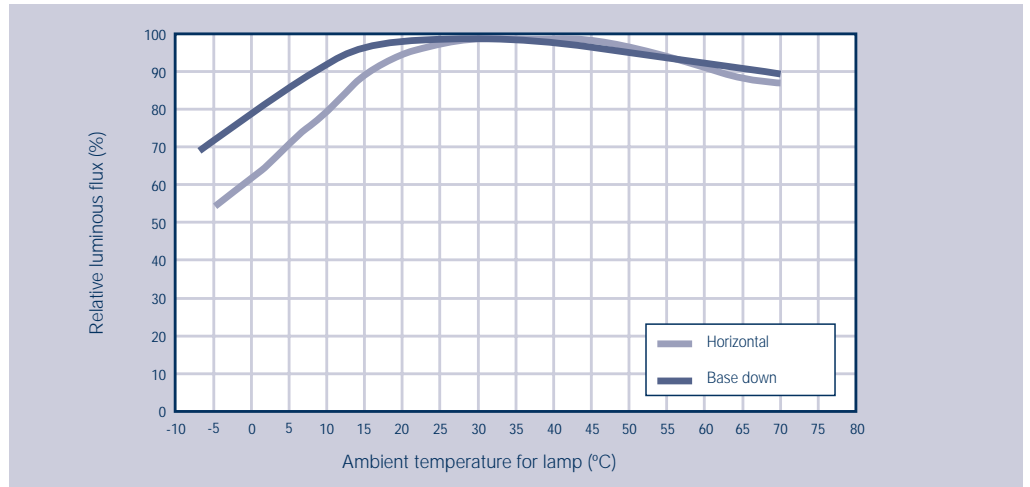

Typical luminous flux/temperature curve for OSRAM DULUX® T IN and OSRAM DULUX® T/E IN for high ambient temperatures

**4.6.3 Luminous flux/  
 temperature curves  
 for OSRAM  
 DULUX® L SP for  
 outdoor lighting**

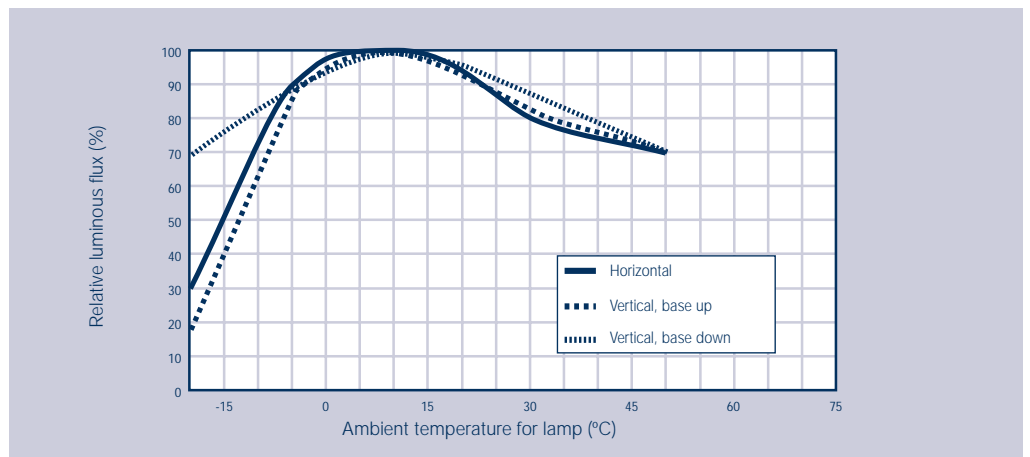

Typical luminous flux/temperature curve for OSRAM DULUX® L SP for outdoor lighting.

#### 4.6.4 Operation at high temperatures

On conventional linear fluorescent lamps, the cold spot is normally in the centre of the lamp. Additionally the luminaire will generally have a large radiating surface which will ensure moderate tube wall temperatures and high efficiency. In contrast to linear fluorescent lamps, compact fluorescent lamps are much shorter despite having high lamp wattages. There is therefore a tendency to make luminaires as small as possible. Often the thermal characteristics are ignored.

In particularly small enclosed luminaire systems the temperatures at the points on normal OSRAM DULUX® lamps that have a major influence on luminous flux are so high that luminous flux and therefore the efficiency of the luminaire are reduced appreciably.

**Because in such cases the lamps are no longer operated at their optimum there are also changes in the electrical values of the lamp (reduced lamp power) at high ambient temperatures, which in turn will impair the control gear and shorten the life of the lamp. It is important therefore to take into consideration the maximum temperatures permitted on the lamp (see 4.8).**

At high ambient temperatures, at which conventional OSRAM DULUX® lamps cannot be operated at their optimum (reduced luminous flux), it makes sense to use OSRAM DULUX® IN amalgam lamps to achieve maximum luminous flux. Since they achieve their optimum mercury vapour pressure at a high lamp ambient temperature, amalgam lamps operate at their optimum efficiency under the same conditions in narrow luminaires and therefore achieve a higher lamp power.

All the electrical and photometric values (lamp current, lamp voltage and luminous flux) relate to the higher lamp output. In narrow luminaires equipped with OSRAM DULUX® IN lamps, there is therefore more heat released than is the case with normal OSRAM DULUX® lamps. This leads to an increase in temperature at the IEC measuring point and must be taken into consideration when designing the luminaires. The maximum permitted temperature at the IEC measuring point is 140 °C (measuring point 1, see 4.8).

#### 4.6.5 Operation at low temperatures

The following points must be taken into account when operating OSRAM DULUX® lamps on CCGs and ECGs at low temperatures:

1. The lamp must be capable of starting at the required temperature.
2. After ignition, the tube wall must warm up sufficiently for the lamp to operate within its optimum range

The low ambient temperatures at which OSRAM DULUX® will ignite reliably in conjunction with conventional control gear are shown in 4.2. If operated with appropriate electronic control gear, OSRAM DULUX® lamps with four-pin bases can ignite at even lower temperatures.

In low-temperature applications, the lamps should be used only in enclosed luminaires. It is important for the volume of the luminaire to be such that the lamp(s) can warm up rapidly so that ambient temperatures at which the lamps will operate efficiently are reached within a short time. If there are considerable fluctuations in temperature, the luminous flux/temperature curves for the different burning positions should be studied in order to arrive at a suitable compromise between lamp and luminaire efficiency.

OSRAM DULUX® T/E IN lamps (amalgam lamps), particularly the high-wattage models, can also be used at low temperatures in luminaires of suitable dimensions. However, they will take longer to reach their full luminous flux.

## 4.7 Dimming

Important notes regarding the dimming of compact lamps with and without amalgam:

- For optimum operation, new lamps should be aged for 100 hours at full output before they are dimmed for the first time.
- Amalgam lamps react more slowly than lamps without amalgam. For this reason it is best not to mix the two types in a system.
- Colour temperature differences of around 150 K are noticeable between dimmed (3 % luminous flux) and undimmed lamps (100 % luminous flux).
- When the lamps are dimmed to the lowest dimmer setting (3 % luminous flux) the colour temperature shift compared with undimmed lamps is initially around 500 K. After a stabilization period of 30 to 40 minutes (amalgam lamps) and 20 to 30 minutes (for lamps without amalgam) this reduces to about 150 K.

### 4.7.1 Dimming of OSRAM DULUX®.../E IN amalgam lamps

The technical requirements for dimming also apply to amalgam lamps without restrictions. Note also that the chemical activity of the amalgam causes a delayed reaction of the lamp with regard to changes in power. This generally occurs with visible differences from one lamp to another. When amalgam lamps are dimmed there may therefore be noticeable differences in brightness and colour perception between lamps of the same type, even if they are operated under identical conditions.

The luminous flux of free-burning OSRAM DULUX® IN lamps stabilises at 100 % after 15 to 30 minutes. In the case of OSRAM DULUX® lamps without amalgam the luminous flux stabilises within less than 10 minutes.

These differences in brightness between amalgam lamps of the same wattage can also occur if the lamps are operated in luminaires with different volumes. In such cases the different temperatures within the luminaires have an effect.

Amalgam lamps can however be dimmed, with the restrictions mentioned above.

If the lamps are stored or left off for a long period of time (> 20 hours) the mercury may migrate into the amalgam. At low dimmer settings and ambient temperatures there is then the possibility that the lamp will produce only very low light output (Hg-free stage, burning pink). This is caused by a too low discharge temperature (Hg).

The solution is to allow the lamp to operate for about 5 minutes at full output and then to dim it (no damage to the lamp).

For optimum operation, new lamps should be aged for 100 hours at full output before they are dimmed for the first time.

**4.8 Lamp temperatures and limiting values**

Temperature measuring points are defined for OSRAM DULUX® lamps. The temperatures at these points must be within the thresholds for the safe and reliable operation of the lamps.

Temperature measuring points:

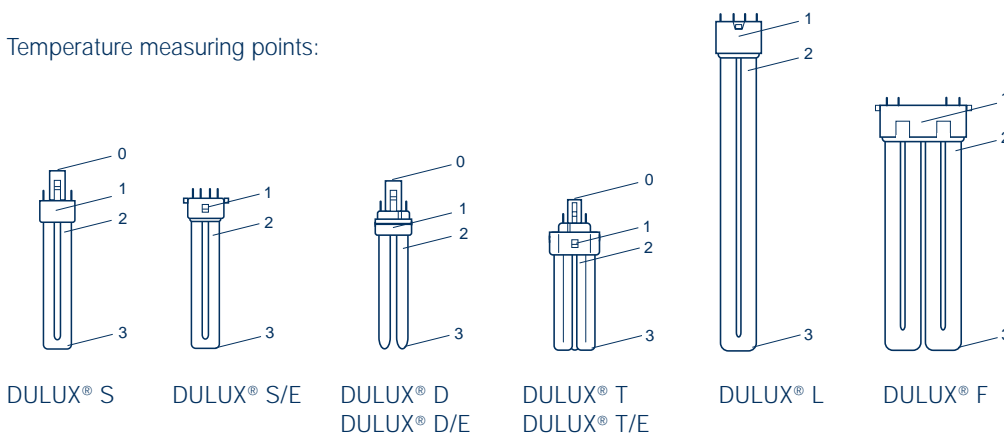

The following limit temperatures must not be exceeded at these points even under adverse installation conditions (in the luminaire, high room temperatures) and at high supply voltages:

Measuring point	Description	Max. temp.
0	This point is located at the bottom of the base and is determined by the thermal load capacity of the glow starter installed in the bases of two-pin lamps for conventional operation. It is therefore relevant only for these lamps (OSRAM DULUX® S, D, T and T IN).	90°C <sup>1)</sup> according to EN 60901
1 IEC measuring point	The hottest point on the surface of the base on a line which on G23, 2G7 bases (OSRAM DULUX® S and OSRAM DULUX® S/E) is 8 mm and on G24, GX24, 2G10 and 2G11 bases (OSRAM DULUX® D, D/E, T, T/E, L and F) 12 mm from the reference plane in the direction of the glass bulb. The limit value for this measuring point has been defined in the relevant standard for safety reasons. (If this maximum temperature is exceeded the plastic base may start to soften (applies to end of life).)	140°C <sup>2)</sup> according to EN 61199 Information for luminaire design as per IEC.
2 Electrode measuring point	Measuring point 2 at the glass tube near the filament is the hottest point on the lamp. Measurements are taken 5 mm from the edge of the base.	max. 190°C
3 Cold spot measuring point	Applies only to OSRAM DULUX® 2-pin and OSRAM DULUX® 4-pin lamps <u>without amalgam</u> . Corresponds to the cold spot for base-up burning position and a free-burning lamp. In certain circumstances and with other burning positions in the luminaire, however, the cold spot may be somewhere other than measuring point 3. Exceeding the maximum permitted temperature has a considerable impact on the electrical and photometric data of the lamp and will cause the lamp to fail.	In CCG and ECG operation max. 100°C (approx. 60% luminous flux) optimum 40°–50°C (= 100% luminous flux)
Amalgam measuring point	<b>Amalgam lamps:</b> The measuring point for amalgam lamps is <u>on the lamp glass of the amalgam reservoir inside the lamp base</u> . This temperature can be measured only with specially prepared lamps.	85°–115°C (= 90% luminous flux)

<sup>1)</sup> Measuring conditions: 25°C ambient temperature, draught free air  
 Reference ballast  
 Supply voltage  $U_V = 1.06 \times U_{Rated}$

<sup>2)</sup> Measuring conditions: Short-circuited starter  
 25°C ambient temperature, draught free air  
 Supply voltage  $U_V = 1.1 \times U_{Rated}$   
 Reference ballast



**4.8.1 Maximum temperatures for DULUX®-Lamps**

The following table shows the permitted maximum temperatures on OSRAM DULUX® lamps. Exceeding one or more of the maximum values specified here will lead to:

- a noticeable reduction in lamp life
- and/or damage to the CCG or ECG
- and/or damage to the lamp base and the luminaire holder.

In the case of OSRAM DULUX® S, D, T (without amalgam), L and F the limit value of 100 °C at **measuring point 3** (cold spot) should not be exceeded. Exceeding this limit value may cause the lamp to fail.

At cold spot temperatures above the optimum (see table 4.8) there are changes in the electrical and photometric data of the lamps (the luminous flux is no longer at 100 %).

The limit value at **measuring point 1** is 140 °C for OSRAM DULUX® lamps with and without amalgam. This maximum value was defined as part of the IEC standard for safety reasons. Exceeding this value leads to softening of the plastic base and discolouration of the base material.

Measuring point limit values	0 As per EN 60901	1 As per EN 61199	2 <sup>(1)</sup>	3 <sup>(2)</sup>
OSRAM DULUX® 2-pin (CCG operation)	90 °C	140 °C	190 °C	100 °C
OSRAM DULUX® 4-pin (ECG operation)	–	140 °C	190 °C	100 °C
OSRAM DULUX® IN 2-pin (CCG operation)	90 °C	140 °C	190 °C	–
OSRAM DULUX® IN 4-pin (ECG operation)	–	140 °C	190 °C	–

1) Measuring point 2 on the glass tube near to the filament is the hottest point on the lamp. Measurements are taken 5 mm from the edge of the base.

2) Maximum limit value of the mercury vapour pressure (see 1.4)

On amalgam lamps (OSRAM DULUX® T and T/E...IN), the cold spots are not at the bend in the lamp but in the lower half of the discharge tube inside the base. As far as the luminous flux/temperature curve is concerned, it is not the value at measuring point 3 that is relevant but at the **amalgam measuring point** inside the base. The optimum amalgam temperature at the measuring point (amalgam reservoir) is between 85 °C and 115 °C. This temperature can be measured only with specially prepared lamps.

Undershooting or overshooting the temperature range will lead to a reduction in lamp power and luminous flux.

Measuring point 1 (IEC measuring point) is not relevant for determining the amalgam temperature and should not be used for this purpose.

In addition, any information from ECG manufacturers regarding the permissible limit values at temperature measuring point T<sub>c</sub> on the ECG must be observed. If these limit values are exceeded the life of the ECG will be reduced.



**5 Data for control gear manufacturers**

Fluorescent lamps and compact fluorescent lamps cannot be operated directly from the mains supply; they need a control gear. This may be integrated in the lamp (as in the case of OSRAM DULUX® EL lamps) or may take the form of an external unit connected between the lamp and the mains outlet (as with all CFLs with pin bases). Models with two-pin bases are designed to operate with conventional control gear; lamps with four-pin bases are designed to operate with electronic control gear (high frequency operation). In either case, the operating data of the control gear must be tailored to the lamp data.

**5.1 Electronic operation**

The advantages of high-frequency operation are greater economy, longer lamp life, greater switching resistance and more comfortable light than it is the case with choke/starter circuits. To make best use of these advantages, however, it is important to ensure that the permissible operating data listed below for preheating, igniting and operating the lamps maintained. The values in the table apply to an operating frequency of 25 kHz and a sinusoidal voltage (crest factor 1.4) during operation with no ignition aids.

**5.1.1 Preheating (ECG operation)**

Starting lamps with filament preheating (warm start) is recommended by OSRAM as the standard starting procedure. In a warm start, the electrodes are heated by a preheating current with energy  $Q_{preheat}$  to the emission temperature before the lamp is ignited.

The necessary or permissible preheating current is determined by the design of the electrodes and the preheating time  $t_{preheat}$  selected. Preheating times of less than 0.4 s are generally not permissible for compact fluorescent lamps. This is because with such short times it is impossible to ensure sufficiently uniform heating along the entire length of the electrode.

The minimum and maximum permitted preheating energy can be calculated using the parameters in the following table for various preheating times. Violating these limit values will cause blackening around the electrodes and shorter lamp life, particular if the lamp is switched on and off frequently. Compliance with the prescribed limits is tested on control gear using an equivalent resistor  $R_{sub}$  which is connected to the control gear instead of the lamp electrodes. The energy fed into this resistor is measured over the selected preheating time. For the testing of the minimum limit  $Q_{preheat, min}$  a substitution resistor  $R_{sub min}$  is used. For the maximum limit (correspond with a higher electrode resistance) a substitution resistor  $R_{sub max}$  is used.

$R_{sub max}$  is separately defined, the rule of thumb  $R_{sub max} = 4/3 \cdot R_{sub min}$  is in force. The minimum and maximum value of the preheat energy is calculated by

$$Q_{preheat, min} = Q + Pt_{preheat}$$

$$Q_{preheat, max} = 2 \cdot Q_{preheat, min}$$

If electrode preheating is carried out with a constant current  $I_{preheat}$  or constant voltage  $U_{preheat}$  the necessary current or voltage can be calculated as follows:

$$U_{preheat, constant} = \sqrt{\frac{QR_{sub}}{t_{preheat}} + PR_{sub}}$$

$$I_{preheat, constant} = \sqrt{\frac{Q}{R_{sub}t_{preheat}} + \frac{P}{R_{sub}}}$$

5.1.1 Preheating  
(ECG operation)  
continued

Lamp	P [W]		Q [J]		R <sub>sub</sub> [Ω]	
	min	max	min	max	min	max
OSRAM DULUX® S/E 5 W	0.5	1.0	1.0	2.0	30	40
OSRAM DULUX® S/E 7 W	0.5	1.0	1.0	2.0	30	40
OSRAM DULUX® S/E 9 W	0.5	1.0	1.0	2.0	30	40
OSRAM DULUX® S/E 11 W	0.5	1.0	1.0	2.0	30	40
OSRAM DULUX® D/E 10 W	0.6	1.2	1.0	2.0	30	40
OSRAM DULUX® D/E 13 W	0.7	1.4	1.0	2.0	30	40
OSRAM DULUX® D/E 18 W	0.7	1.4	0.9	1.8	18	24
OSRAM DULUX® D/E 26 W	0.8	1.6	1.0	2.0	9	12
OSRAM DULUX® T/E 13 W <sup>1)</sup>	0.7	1.4	1.0	2.0	30	40
OSRAM DULUX® T/E 18 W <sup>1)</sup>	0.7	1.4	0.9	1.8	18	24
OSRAM DULUX® T/E 26 W <sup>1)</sup>	0.8	1.6	1.0	2.0	9	12
OSRAM DULUX® T/E 32 W <sup>1)</sup>	0.8	1.6	1.0	2.0	9	12
OSRAM DULUX® T/E 42 W <sup>1)</sup>	0.8	1.6	1.0	2.0	9	12
OSRAM DULUX® T/E 57 W IN	0.8	1.6	1.0	2.0	9	12
OSRAM DULUX® T/E 70 W IN	0.8	1.6	1.0	2.0	9	12
OSRAM DULUX® L 18 W	0.9	1.8	1.5	3.0	8	11
OSRAM DULUX® L 24 W	0.9	1.8	1.5	3.0	8	11
OSRAM DULUX® L 36 W	1.0	2.0	1.6	3.2	7	9
OSRAM DULUX® L 40 W	0.9	1.8	1.5	3.0	8	11
OSRAM DULUX® L 55 W	1.1	2.2	2.4	4.8	5	6.5
OSRAM DULUX® L 80 W	1.5	3.0	2.4	4.8	5	6.5
OSRAM DULUX® F 18 W	0.9	1.8	1.5	3.0	8	11
OSRAM DULUX® F 24 W	0.9	1.8	1.5	3.0	8	11
OSRAM DULUX® F 36 W	1.0	2.0	1.6	3.2	7	9

<sup>1)</sup> Also for IN model

**5.1.2 Starting  
(ECG operation)**

The lamp should not ignite during the preheating time; the open-circuit voltage of the ECG must therefore not exceed a lamp-specific maximum value. After the preheating phase the lamp should ignite reliably; the open-circuit voltage of the ECG must therefore not fall below a lamp-specific minimum value. The following table contains the permissible or necessary limit values for the open-circuit voltage of the ECG. Because of the temperature response of the ignition voltage of fluorescent lamps and compact fluorescent lamps, these values are given for two ambient temperature ranges.

Lamp	Maximum open-circuit voltage during preheating $V_{rms}$	Minimum open-circuit voltage for ignition	
		Ambient temperature >+10°C $V_{rms}$	Ambient temperature -15°C to +10°C $V_{rms}$
OSRAM DULUX® S/E 5 W	120	250	300
OSRAM DULUX® S/E 7 W	130	270	320
OSRAM DULUX® S/E 9 W	150	290	340
OSRAM DULUX® S/E 11 W	170	330	370
OSRAM DULUX® D/E 10 W	180	340	360
OSRAM DULUX® D/E 13 W	190	380	420
OSRAM DULUX® D/E 18 W	220	400	460
OSRAM DULUX® D/E 26 W	240	420	520
OSRAM DULUX® T/E 13 W	190	400	430
OSRAM DULUX® T/E 18 W	250	430	450
OSRAM DULUX® T/E 26 W	265	500	520
OSRAM DULUX® T/E 32 W	265	530	550
OSRAM DULUX® T/E 42 W	265	550	575
OSRAM DULUX® T/E 18 W IN	250	550	550
OSRAM DULUX® T/E 26 W IN	265	550	560
OSRAM DULUX® T/E 32 W IN	265	560	600
OSRAM DULUX® T/E 42 W IN	265	600	600
OSRAM DULUX® T/E 57 W IN	350	640	660
OSRAM DULUX® T/E 70 W IN	350	700	750
OSRAM DULUX® L 18 W	150	300	320
OSRAM DULUX® L 24 W	170	320	340
OSRAM DULUX® L 36 W	190	340	380
OSRAM DULUX® L 40 W	220	360	420
OSRAM DULUX® L 55 W	220	360	420
OSRAM DULUX® L 80 W	230	370	420
OSRAM DULUX® F 18 W	130	350	390
OSRAM DULUX® F 24 W	170	400	440
OSRAM DULUX® F 36 W	190	420	480



**5.1.3 Operating data for undimmed lamps**

All the lamp data is specified only for operation at rated current. The lamp current may vary within the tolerance range without affecting lamp life. The precise data is shown in the table. In this range there is no need for constant heating current to maintain the electrodes at emission temperature.

The critical load of a lamp is determined by two criteria: the maximum lamp current and the maximum current maximum in any lead. The lamp current is the current that goes through the discharge in the lamp. The current maximum in any lead is a limit value for the load capacity of the power supply leads if a heating current flows in addition to the lamp current. The current in any lead equals approximately the lamp current plus the heating current.

Lamp	Minimum lamp current mA	Maximum lamp current <sup>1)</sup> mA	Maximum current in any lead mA
OSRAM DULUX® S/E 5 W	120	190	240
OSRAM DULUX® S/E 7 W	120	190	240
OSRAM DULUX® S/E 9 W	120	190	240
OSRAM DULUX® S/E 11 W	120	190	240
OSRAM DULUX® D/E 10 W	135	210	240
OSRAM DULUX® D/E 13 W	120	190	240
OSRAM DULUX® D/E 18 W	160	240	330
OSRAM DULUX® D/E 26 W	220	360	480
OSRAM DULUX® T/E 13 W	120	190	240
OSRAM DULUX® T/E 18 W <sup>2)</sup>	160	240	330
OSRAM DULUX® T/E 26 W <sup>2)</sup>	220	360	480
OSRAM DULUX® T/E 32 W <sup>2)</sup>	220	360	480
OSRAM DULUX® T/E 42 W <sup>2)</sup>	220	360	480
OSRAM DULUX® T/E 57 W IN	220	360	420
OSRAM DULUX® T/E 70 W IN	220	360	420
OSRAM DULUX® L 18 W	260	425	640
OSRAM DULUX® L 24 W	260	425	640
OSRAM DULUX® L 36 W	300	500	700
OSRAM DULUX® L 40 W	260	425	640
OSRAM DULUX® L 55 W	450	650	780
OSRAM DULUX® L 80 W	425	690	740
OSRAM DULUX® F 18 W	260	425	640
OSRAM DULUX® F 24 W	260	425	640
OSRAM DULUX® F 36 W	300	500	700

This table complies with the latest edition of IEC 60901 and 61199. IEC 61199 is currently being revised. As a result, some values may change.

<sup>1)</sup> Exceeding the maximum lamp current may shorten lamp life (overheating of the base) and a decrease in maintenance

<sup>2)</sup> Also for IN model

5.1.4 Dimming

Reducing the lamp current below the minimum value specified in 5.1.3 can be used to reduce the luminous flux of the lamp appreciably below its rated value, thereby dimming the lamp. Please note the following:

- The lamp electrodes must be maintained at emission temperature by a continuous heating current.
- The lamp voltage at lower discharge current is generally higher than the rated value.
- The chromaticity coordinate of the light colour may deviate from its specified value.

In the interest of maximising lamp life, the auxiliary heating current must be matched to the lamp current. If the auxiliary heating current is too low, the lamp electrodes will very quickly be destroyed by sputtering. A constant heating current that is too high will result in excessive emitter evaporation which leads to end blackening.

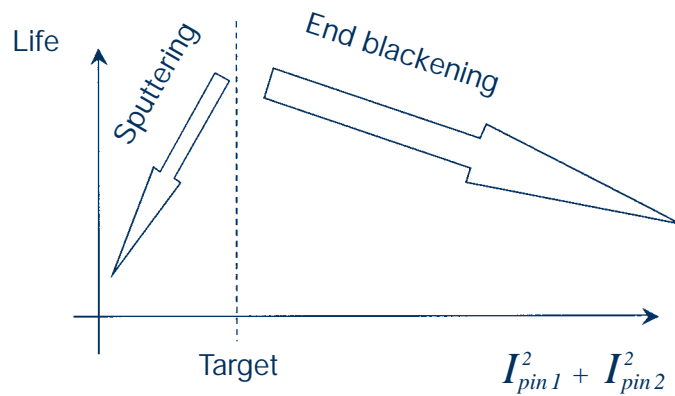

Generally speaking, it is not easy to measure the continuous heating current when the lamp is being operated on an electronic control gear because the current is fed to the electrodes in the lamp via the two lead wires in a split that depends on the design of the control gear, and because the lamp current and the auxiliary heating current may differ in phase, curve shape and frequency. Therefore it is not reasonable to specify the necessary auxiliary heating current as a function of the lamp current.

The important variable for electrode heating is the electrical heating power  $P_{heat}$  fed to the electrode. As

$$P_{Heat} = P_{Lamp\ current} + P_{Heating\ current} = f(I^2_d, I^2_{Heat}) \approx f(I^2_d + I^2_{Heat})$$

or

$$P_{Heat} \approx f(I^2_{Pin\ 1} + I^2_{Pin\ 2})$$

the necessary auxiliary heating current can also be specified as a function of lamp current by indicating the total of  $I^2_{Pin\ 1} + I^2_{Pin\ 2}$ , where  $I_{Pin\ 1}$  and  $I_{Pin\ 2}$  are the two pin currents at an electrode in the lamp.  $I_{Pin\ 1}$  and  $I_{Pin\ 2}$  can be easily measured on electronic control gear.

As the diagram above shows, there is an ideal target setting for the sum of the squares of the two pin currents at which the lamp life will be at its optimum. If the sum of the squares of the pin currents decreases, sputtering will occur at the electrodes and

lamp life will be drastically reduced. If the sum of the squares of the pin currents increases with respect to the target value, end blackening gradually occurs and at very high values for heating the life of the lamp is gradually reduced due to high thermal evaporation of the emitter material.

The data are shown in the table below:

$$I^2_{\text{Pin 1}} + I^2_{\text{Pin 2}} \Big|_{\text{Target}} = - m_{\text{Target}} * I_d + b_{\text{Target}}$$

$$I^2_{\text{Pin 1}} + I^2_{\text{Pin 2}} \Big|_{\text{min}} = - m_{\text{min}} * I_d + b_{\text{min}}$$

$$I^2_{\text{Pin 1}} + I^2_{\text{Pin 2}} \Big|_{\text{max}} = + m_{\text{max}} * I_d + b_{\text{max}}$$

Lamp	Minimum lamp current [A]	m <sub>Target</sub> [A <sup>2</sup> /A]	b <sub>Target</sub> [A <sup>2</sup> ]	m <sub>min</sub> [A <sup>2</sup> /A]	b <sub>min</sub> [A <sup>2</sup> ]	m <sub>max</sub> [A <sup>2</sup> /A]	b <sub>max</sub> [A <sup>2</sup> ]
OSRAM DULUX® S/E 5 W	0.015	0.072	0.030	0.240	0.030	0.060	0.040
OSRAM DULUX® S/E 7 W	0.015	0.072	0.030	0.240	0.030	0.060	0.040
OSRAM DULUX® S/E 9 W	0.015	0.072	0.030	0.240	0.030	0.060	0.040
OSRAM DULUX® S/E 11 W	0.015	0.072	0.030	0.240	0.030	0.060	0.040
OSRAM DULUX® D/E 10 W	0.015	0.078	0.035	0.260	0.035	0.065	0.045
OSRAM DULUX® D/E 13 W	0.015	0.078	0.035	0.260	0.035	0.065	0.045
OSRAM DULUX® D/E 18 W	0.020	0.105	0.070	0.350	0.070	0.090	0.080
OSRAM DULUX® D/E 26 W	0.030	0.171	0.175	0.570	0.175	0.145	0.210
OSRAM DULUX® T/E 13 W	0.0	0.078	0.035	0.260	0.035	0.065	0.045
OSRAM DULUX® T/E 18 W <sup>1)</sup>	0.020	0.105	0.070	0.350	0.070	0.090	0.080
OSRAM DULUX® T/E 26 W <sup>1)</sup>	0.030	0.171	0.175	0.570	0.175	0.145	0.210
OSRAM DULUX® T/E 32 W <sup>1)</sup>	0.030	0.171	0.175	0.570	0.175	0.145	0.210
OSRAM DULUX® T/E 42 W <sup>1)</sup>	0.030	0.171	0.175	0.570	0.175	0.145	0.210
OSRAM DULUX® T/E 57 W IN	0.030	0.171	0.175	0.570	0.175	0.145	0.210
OSRAM DULUX® T/E 70 W IN	0.030	0.171	0.175	0.570	0.175	0.145	0.210
OSRAM DULUX® L 18 W	0.035	0.189	0.210	0.630	0.210	0.160	0.255
OSRAM DULUX® L 24 W	0.035	0.189	0.210	0.630	0.210	0.160	0.255
OSRAM DULUX® L 36 W	0.040	0.213	0.270	0.710	0.270	0.180	0.325
OSRAM DULUX® L 40 W	0.035	0.189	0.210	0.630	0.210	0.160	0.255
OSRAM DULUX® L 55 W	0.050	0.279	0.450	0.930	0.450	0.235	0.550
OSRAM DULUX® L 80 W	0.055	0.306	0.550	1.020	0.550	0.260	0.665
OSRAM DULUX® F 18 W	0.035	0.189	0.210	0.630	0.210	0.160	0.255
OSRAM DULUX® F 24 W	0.035	0.189	0.210	0.630	0.210	0.160	0.255
OSRAM DULUX® F 36 W	0.040	0.213	0.270	0.710	0.270	0.180	0.325

<sup>1)</sup> Also for IN model

The diagram shows an example of an OSRAM DULUX® D/E 26 W lamp.

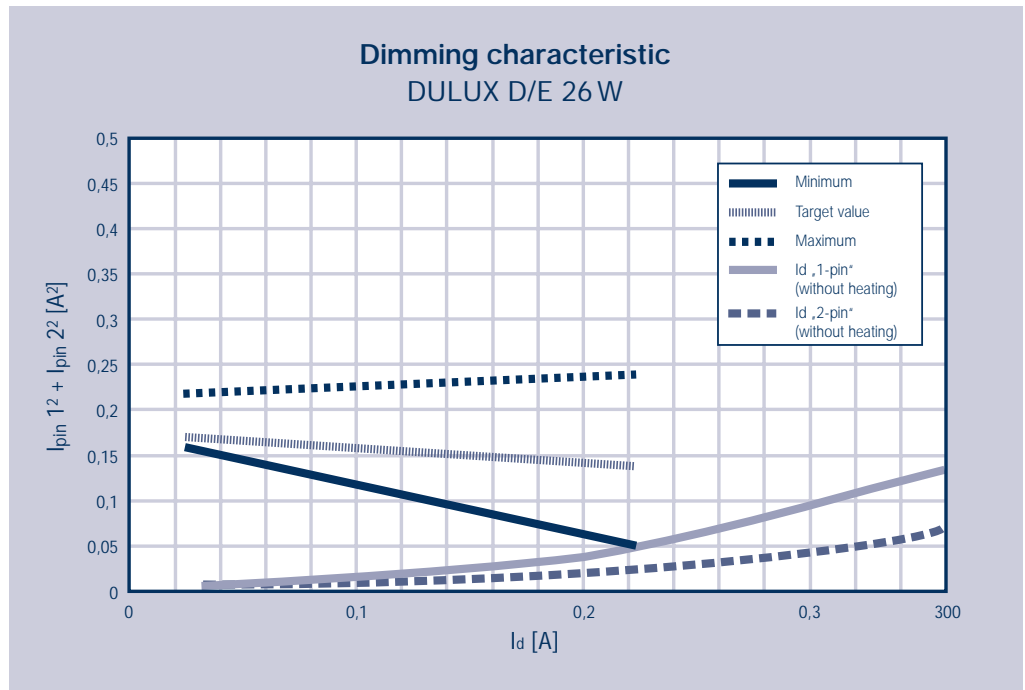

The  $I_{d,1-pin}$  and  $I_{d,2-pin}$  lines in the diagram show the discharge current for the two limiting cases.

1. The discharge current of the lamp is fed only via one lead wire
2. The discharge current of the lamp is fed equally via the two lead wires

The intersection of the curve with the line  $I_{d,1-pin}$  with  $I_{Pin 1}^2 + I_{Pin 2}^2 \min$  (= minimum) gives the value of the minimum discharge current below which heating must be provided.

The optimum dimming operation would be along the target line. If there are any deviations toward smaller values for  $I_{Pin 1}^2 + I_{Pin 2}^2$  the life of the lamp will be significantly reduced. If  $I_{Pin 1}^2 + I_{Pin 2}^2$  is above the target value, blackening might be observed at the ends of the lamp. Proper lamp operation cannot take place below the „Minimum“ line or above the „Maximum“ line. Only burning duration tests can give a reliable indication of achievable lamp life in dimmer mode. These tests must be performed by the control gear manufacturers. Control gear manufacturers are also responsible for carrying out tests on the permissible ambient temperature ranges and on stability in dimmer mode.

**For optimum operation, new lamps should be burnt in for 100 hours at full output before they are dimmed for the first time.**

**5.2 Conventional operation**

The following table shows the data for conventional control gear for OSRAM DULUX® lamps.

**5.2.1 Conventional operation  
 220 V, 230 V and  
 240 V / 50 Hz**

Lamp	Preheating						Ignition							
	Impedance $\Omega$ <sup>1)</sup>			Rated preheating current mA		Preheating current		Substitution resistance <sup>2)</sup> $\Omega$			Open-circuit voltage			
	At 220 V	At 230 V	At 240 V	Rated value at 220/230/240		min mA	max mA	At 220 V	At 230 V	At 240 V	220 V min Vrms	230 V min Vrms	240 V min Vrms	max V <sub>Peak</sub>
DS 5 W	1180	1240	1300	190	190	153	240	160	160	160	198	207	216	400
DS 7 W	1180	1240	1300	190	190	153	240	160	160	160	198	207	216	400
DS 9 W	1180	1240	1300	190	190	153	240	160	160	160	198	207	216	400
DS 11 W	1180	1240	1300	190	190	153	240	160	160	160	198	207	216	400
2 x DS 5 W	1070	1140	1210	190	190	153	240	320	320	320	198	207	216	400
2 x DS 7 W	1070	1140	1210	190	190	153	240	320	320	320	198	207	216	400
2 x DS 9 W	1070	1140	1210	190	190	153	240	320	320	320	198	207	216	400
DD 10 W	1070	1140	1210	210	210	153	275	100	100	100	198	207	216	440
DD 13 W	1070	1140	1210	210	210	153	275	100	100	100	198	207	216	440
DD 18 W	800	845	900	280	280	190	375	80	80	80	198	207	216	440
DD 26 W	540	571	610	420	420	270	550	25	25	25	198	207	216	440
DT 13 W <sup>3)</sup>	1070	1140	1210	210	210	153	275	100	100	100	198	207	216	440
DT 18 W <sup>3)</sup>	800	845	900	280	280	190	375	80	80	80	198	207	216	440
DT 26 W <sup>3) 4)</sup>	540	571	610	420	420	270	550	25	25	25	198	207	216	440
DL 18 W	540	568	600	510	510	315	670	50	50	50	198	207	216	400
DL 24 W	540	568	600	510	510	315	670	50	50	50	198	207	216	400
DL 36 W	390	419	447	650	650	365	775	40	40	40	198	207	216	400
2 x DL 18 W	390	419	447	540	510	315	670	80	100	100	198	207	216	400
DF 18 W	540	568	600	510	510	315	670	50	50	50	198	207	216	400
DF 24 W	540	568	600	510	510	315	670	50	50	50	198	207	216	400
DF 36 W	390	419	447	650	650	365	775	40	40	40	198	207	216	400
2 x DF 18 W	390	419	447	540	510	315	670	80	100	100	198	207	216	400

<sup>1)</sup> For the calibration current of the reference control gear (see 2.2.2 and 2.2.3) Tolerance  $\pm 3\%$ .

<sup>2)</sup> Substitution resistance of both electrodes connected in series.

<sup>3)</sup> Control gear for OSRAM DULUX® D 13, 18 and 26 W can also be used to operate OSRAM DULUX® T 13, 18 and 26 W.

<sup>4)</sup> Also for IN model

**5.3 Electrical data for the filaments**

The electrode or filament is an extremely important component of a fluorescent lamp. To operate the lamp at its optimum it is essential for the filament to be maintained within a particular temperature range. To ensure that this is the case even if control gear is operated with lamps from different manufacturers, the filament data are standardised.

The filament of a compact fluorescent lamp is defined such that the warm resistance  $R_T$  specified in the following table is in equilibrium when the specified test current flows through the filament. The cold resistance is not standardised and is shown here for the purposes of completeness only.

Lamp	Test current $I_T$ mA	Warm resistance $R_T$ at $I_T$ $\Omega$	Cold resistance $R_0$ measured at the pins $\Omega^{2)}$
OSRAM DULUX® S+S/E 5 W	130	50±12.5	11.1
OSRAM DULUX® S+S/E 7 W	130	50±12.5	11.1
OSRAM DULUX® S+S/E 9 W	130	50±12.5	11.1
OSRAM DULUX® S+S/E 11 W	130	50±12.5	11.1
OSRAM DULUX® D+D/E 10 W	140	50±12.5	11.1
OSRAM DULUX® D+D/E 13 W	140	50±12.5	11.1
OSRAM DULUX® D+D/E 18 W	190	26±6.5	6.2
OSRAM DULUX® D+D/E 26 W	310	13±3.25	3.3
OSRAM DULUX® T+T/E 13 W	140	50±12.5	11.1
OSRAM DULUX® T+T/E 18 W <sup>1)</sup>	190	26±6.5	6.2
OSRAM DULUX® T+T/E 26 W <sup>1)</sup>	310	13±3.25	3.3
OSRAM DULUX® T/E 32 W <sup>1)</sup>	310	13±3.25	3.3
OSRAM DULUX® T/E 42 W <sup>1)</sup>	310	13±3.25	3.3
OSRAM DULUX® T/E 57 W IN	310	13±3.25	3.3
OSRAM DULUX® T/E 70 W IN	310	13±3.25	3.3
OSRAM DULUX® L 18 W	340	12±3.0	3.1
OSRAM DULUX® L 24 W	340	12±3.0	3.1
OSRAM DULUX® L 36 W	385	11±2.75	2.9
OSRAM DULUX® L 40 W	340	12±3.0	3.1
OSRAM DULUX® L 55 W	500	8±2.0	2.3
OSRAM DULUX® L 80 W	530	8±2.0	2.1
OSRAM DULUX® F 18 W	340	12±3.0	3.1
OSRAM DULUX® F 24 W	340	12±3.0	3.1
OSRAM DULUX® F 36 W	385	11±2.75	2.9

<sup>1)</sup> Also for IN model

<sup>2)</sup> Guide value

## 6 Accessories

### 6.1 Bases and lampholders

OSRAM DULUX® lamps from the various ranges and compatible lamps from other manufacturers have different bases, some of which are also coded differently. This prevents the wrong type of lamp from being used. Using the wrong lamp in a luminaire impairs the safety of the system, often constitutes a fire risk and leads in most cases to premature lamp failure. It is also important, however, to follow the instructions of the luminaire manufacturer in selecting the right lamp. This applies in particular to cases where the same base/lampholder system is used for two or more lamps (e.g. GX24q-3 for OSRAM DULUX® T/E 26 W and 32 W, 2G11 for OSRAM DULUX® L 18 W to 80 W and 2G10 for OSRAM DULUX® F 18 W to 36 W). In the case of OSRAM DULUX® S and OSRAM DULUX® S/E 5 W to 11 W, there is no need to code the G23 or 2G7 bases owing to the minimal differences between the wattages.

Lampholders have a dual role in that they supply power to the lamp and hold the lamp in position. They must also be able to withstand high temperatures. The quality of the lampholder is therefore an important aspect. Another factor to bear in mind is that the lampholder must be strong enough to withstand the stresses involved in removing old lamps and inserting new lamps several times during the lifetime of the luminaire. The various OSRAM DULUX® bases and their coding are listed below (for diagrams see 2.1 Geometrical data).

Lamp	Base		Starter	Coding
OSRAM DULUX® S 5, 7, 9, 11 W	G23	2-pin	integrated	none
OSRAM DULUX® S/E 5, 7, 9, 11 W	2G7	4-pin	none	none
OSRAM DULUX® D 10, 13 W	G24d-1	2-pin	integrated	1 bar central
OSRAM DULUX® D 18 W	G24d-2	2-pin	integrated	1 bar left
OSRAM DULUX® D 26 W	G24d-3	2-pin	integrated	1 bar right
OSRAM DULUX® D/E 10, 13 W	G24q-1	4-pin	none	1 bar central, short guidepost <sup>1)</sup>
OSRAM DULUX® D/E 18 W	G24q-2	4-pin	none	1 bar left, short guidepost <sup>1)</sup>
OSRAM DULUX® D/E 26 W	G24q-3	4-pin	none	1 bar right, short guidepost <sup>1)</sup>
OSRAM DULUX® T 13 W	GX24d-1	2-pin	integrated	1 bar central, compatible with G24d-1
OSRAM DULUX® T 18 W <sup>2)</sup>	GX24d-2	2-pin	integrated	1 bar left, compatible with G24d-2
OSRAM DULUX® T 26 W <sup>2)</sup>	GX24d-3	2-pin	integrated	1 bar right, compatible with G24d-3
OSRAM DULUX® T/E 13 W <sup>2)</sup>	GX24q-1	4-pin	none	1 bar central, short guidepost <sup>1)</sup> , compatible with G24q-1
OSRAM DULUX® T/E 18 W <sup>2)</sup>	GX24q-2	4-pin	none	1 bar left, short guidepost <sup>1)</sup> , compatible with G24q-2
OSRAM DULUX® T/E 26 W, 32 W <sup>2)</sup>	GX24q-3	4-pin	none	1 bar right, short guidepost <sup>1)</sup> compatible with G24q-3
OSRAM DULUX® T/E 42 W	GX24q-4	4-pin	none	2 bars central, short guidepost <sup>1)</sup>
OSRAM DULUX® T/E 57 W IN	GX24q-5	4-pin	none	1 bar central, short guidepost with coding slits
OSRAM DULUX® T/E 70 W IN <sup>4)</sup>	GX24q-6	4-pin	none	1 bar left, short guidepost with coding slits
OSRAM DULUX® L 18 <sup>3)</sup> , 24 <sup>3)</sup> , 36, 40, 55, 80 W	2G11	4-pin	none	Coding is as per IEC 60901 in connection with a lamp holder at the prescribed distance from the reference level (see 6.2)
OSRAM DULUX® F 18, 24, 36 W	2G10	4-pin	none	none

<sup>1)</sup> Lamps will still fit in old „deep“ holders.

<sup>2)</sup> Also for IN model (amalgam)

<sup>3)</sup> Also for SP model

<sup>4)</sup> In preparation

In the past, it was possible to insert two-pin lamps in holders designed for four-pin lamps (electronic operation). Because of the starter integrated in the two-pin base, this led to problems such as poor ignition, shorter lamp life and even destruction of the electronic control gear. By shortening the guidepost we have made sure that two-pin lamps cannot be installed in the wrong holders. Lampholder manufacturers offer modified holders or holders in conjunction with adapters that prevent lamps with long guideposts (two-pin lamps) from being installed. Four-pin lamps with short guideposts will continue to fit in old (deep) holders, however.

Suppliers of holders for OSRAM DULUX® lamps are listed in 10.1.

## 6.2 Lamp supports

OSRAM DULUX® L lamps require a lamp support. The distance between the lamp support and the reference plane of the lamp is defined in the EN 60901 standard and is given in the table below.

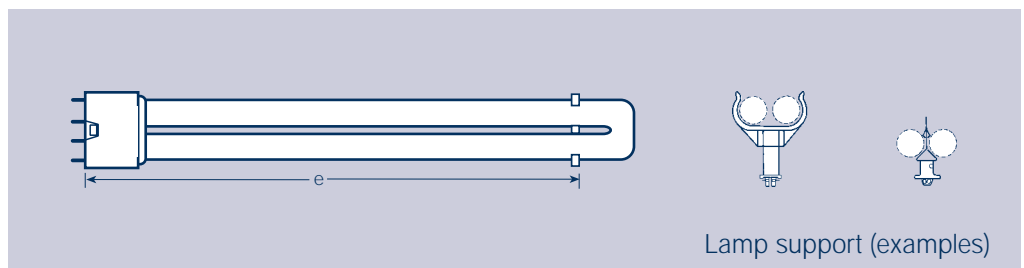

Lamp	Distance from reference plane e	
	Minimum	Maximum
	mm	mm
OSRAM DULUX® L 18 W	140	175
OSRAM DULUX® L 24 W	140	270
OSRAM DULUX® L 36 W	330	365
OSRAM DULUX® L 40 W and 55 W	450	485
OSRAM DULUX® L 80 W	480	515

Lamp supports are optional for other OSRAM DULUX® lamps, such as OSRAM DULUX® S and OSRAM DULUX® F. Lamp supports are offered by lampholder manufacturers (see 10.1).



### 6.3 Starters

In CCG operation, OSRAM DULUX® L and OSRAM DULUX® F lamps require a starter for ignition. There is a choice of conventional glow starters or what are known as safety starters, such as the OSRAM DEOS® starters. Conventional glow starters should be replaced whenever lamps are replaced to ensure trouble-free ignition. This is not necessary with safety starters since they last four times longer than conventional starters. In addition, safety starters reliably shut down burnt-out or defective lamps in inductive or capacitive operation, which not only saves the choke but prevents annoying flicker from these lamps as they reach the end of their life.

OSRAM DULUX® S, D and T (with two-pin bases) have a specially adapted glow starter integrated in the base which ensures reliable ignition. Therefore they do not require external starters.

OSRAM DULUX® S/E, D/E and T/E (with four-pin bases) are designed for ECG operation and do therefore not have an integrated glow starter.

OSRAM DULUX® S/E, D/E and T/E (13, 18 and 26 W only) can be operated under normal conditions with conventional control gear and an external starter. However, there are no special optimised starters available on the market for this application. See also 3.2.3. In this mode, considerable limitations can therefore be expected, such as greatly reduced lamp life with electrode blackening and longer ignition times. For this reason, this mode of operation is not recommended or supported by OSRAM.

## 7 Measuring OSRAM DULUX® compact fluorescent lamps

OSRAM DULUX® lamps differ, in some cases quite considerably, from conventional fluorescent lamps in terms of their technical characteristics. In measurements, therefore, particular attention should be paid to the following (see also DIN 5032):

1. Defined ageing of the lamp (**100 hours**)
2. Adequate burn-in time (stabilisation) before measurements are taken (**15 hours**)
3. Constant  $T_a$  (ambient temperature) during the measurements
4. No destabilisation due to mechanical vibrations, even when switched off
5. High crest factor for lamp voltage (good rms instruments).
6. Short mains supply and measurement instrument wiring to the lamp (for ECG operation).

If these conditions are met, OSRAM DULUX® lamps display good reproducibility of electrical and photometric values. Reference lamps measured under the following conditions can be obtained from OSRAM (see 7.6).

### 7.1 Aging of the lamps

**Before photometric data is gathered, new lamps should be aged for 100 hours.**

All compact fluorescent lamps must contain a small quantity of mercury in the discharge tube in order to generate light. Some of this mercury, which is in liquid form, vaporises when the lamp is switched on, while the rest condenses at the coolest spot (cold spot). Because the discharge tubes of compact fluorescent lamps have such a narrow cross-section, this transport process takes considerably longer than it does in standard fluorescent lamps. For this reason, once new OSRAM DULUX® lamps have been aged by **100 hours**, they must be „stabilised“ for a further **15 hours** before photometric measurements are performed, otherwise it will not be possible to obtain reproducible measured values. Between stabilisation and measurement, OSRAM DULUX® lamps may be switched off for no more than 24 hours; OSRAM DULUX® ... IN lamps (amalgam lamps) may be switched off for no more than 10 seconds.

**Note:** Stabilisation is not required for lamps **without amalgam** in the base-up position if their position does not change after they have been aged for 100 hours or after the last stabilisation process and if they are conveyed carefully when moved from the burn-in position to the measurement position, avoiding any mechanical vibration, sharp movements or tilting. OSRAM DULUX® L + F are stabilised in the horizontal burning position.

In the measurement position, the lamps should be burnt in for a further 30 minutes before measurements are taken.

**Exception:** OSRAM DULUX® T IN and T/E IN should be burned in for two hours.

Because of the widely different spectrums of OSRAM DULUX® lamps, special care should be taken to ensure good spectral matching of the light receiver to the  $V(\lambda)$  curve according to DIN 5031.

The requirements that the photometer must meet are the same as those for linear fluorescent lamps.

**7.2 Operating position** Free-burning OSRAM DULUX® lamps are generally measured in the base-up position, although according to the IEC the reference burning position for OSRAM DULUX® L and OSRAM DULUX® F lamps is horizontal. The base-up position is chosen because the measurements are easier to take and the results are more reliable since the mercury remains at the cold spot at the bottom even when the lamp is moved. With lamps in the horizontal burning position, the mercury shifts as soon as the lamp is moved, which destabilises the lamp. The difference in luminous flux between the base-up and horizontal operating positions at constant lamp output for OSRAM DULUX® S, S/E, D, D/E, T, T/E is no more than 1 to 2 %. Deviations of 10 to 20 % can be expected for OSRAM DULUX® T IN and T/E IN lamps between base up and horizontal operating position.

**7.3 Constant photometric values** Burnt-in and stabilised OSRAM DULUX® lamps provide reproducible photometric data at constant ambient temperature and in an unchanged operating position. Fluctuations are less than 1 % of the upper range value.

**7.4 Electrical measurements** All the cables, control gear and instruments must be arranged, and if necessary shielded, so that there is no chance of interference from external fields. Use instruments which will supply the level of accuracy required in the measured values.

**Recommendations:**

**Instruments:** **Rms instruments (true RMS)**  
 Accuracy: ±0,2% of the measuring range

**Area of application**  
 Frequency: 0-500 Hz (CCG) scanning rate  
 0-400 kHz (ECG) scanning rate  
 Crest factor: > 2 (CCG)  
 > 3 (ECG)

**Lamp supply:** Supply voltage: Depending on the lamp and control gear (CCG, ECG or reference device)  
 Stability: ± 0,2% during the measurement  
 Total harmonic distortion: < 3%  
 Suitable supply:  
 - Noise-free mains  
 - Electronically regulated stabilisers  
 - Rotary measuring generators  
 - Electronic generators  
 The apparent power of the supply unit should be five times the rated system power.

**7.5 Temperature measurement** The luminous flux and hence the luminous efficacy of OSRAM DULUX® lamps depends on the temperature. To achieve optimum operating conditions for the lamp in the luminaire, it is therefore essential to know either the ambient temperature in the vicinity of the lamp or the cold spot temperature directly on the lamp.



### 7.5.1 Ambient temperature

Unless otherwise indicated, the lamp data in this guide is based on an ambient temperature of  $25^{\circ}\text{C} \pm 1^{\circ}\text{C}$  in draught free air in accordance with DIN 5032 (Sheet 4). Lamp data as a function of actual ambient temperature or cold spot temperature is also measured in draught free air.

### 7.5.2 Cold spot temperature for amalgam-free lamps

The cold spot temperatures are dependent on the burning position and lie approximately in the range from  $40^{\circ}\text{C}$  to  $50^{\circ}\text{C}$  (optimum operating conditions). In the base-up operating position and no air circulation, temperature measuring point 3 (see 4.8 – Lamp temperatures and limit values) generally corresponds to the cold spot. The cold spot can however shift as a result of a different operating position or other influences.



Measuring point 3 (cold spot temperature in base-up operating position) is defined for OSRAM DULUX® lamps at the outer lamp arc, centred on the bulb. (See 4.8) To determine the temperature at measuring point 3 (not in the case of the IN version) thermocouples (NiCr-Ni thermo-elements) are cemented there with a neutral, translucent adhesive.

### 7.5.3 Measuring amalgam lamps

Amalgam lamps (OSRAM DULUX® T IN and T/E IN) are specially designed for high ambient temperatures. They therefore achieve their optimum operating conditions (rated data) only at the high temperatures that occur, for example in compact luminaires. Maximum luminous flux ( $\geq 90\%$  of rated value) is achieved in the  $10$  to  $70^{\circ}\text{C}$  temperature range. If photometric measurements are taken under reference conditions (an ambient temperature of  $25^{\circ}\text{C}$ , see 7.5.1), it must be remembered that the measured luminous flux may be as much as 10% below the maximum luminous flux that the lamp can produce.

### 7.6 Reference lamps

Reference lamps (luminous flux and electrical values) can be obtained from the accredited test laboratory of OSRAM GmbH (DAR register number: DAT-P-043/94-00, Lighting Technology). Reference lamps are also available with thermoelements cemented at measuring point 3. For prices and delivery times please contact:

OSRAM GmbH  
Dept. CFL M-M  
Hellabrunner Str. 1      Tel.: (+49) 89/6213-2604  
D - 81536 München      Fax.: (+49) 89/6213-4052

---

## 8 OSRAM DULUX® and the environment

### 8.1 Contents

Like all discharge lamps, OSRAM DULUX® lamps are sealed systems if used as prescribed. Therefore they do not have any effect on the environment apart from emitting light.

The most important substance in discharge lamps as far as the environment is concerned is mercury. Discharge lamps must contain some mercury in order to generate light. By using a patented dosing procedure, OSRAM has succeeded in reducing the amount of mercury in most models to the currently minimum needed to guarantee reliable operation of around 3 mg per lamp.

### 8.2 Waste disposal

WEEE (Waste Electrical and Electronic Equipment) regulations state that in Europe by July 1, 2005 all old electrical equipment including failed discharge lamps must be sent for proper recycling. For private consumers this means that they will have to hand the old lamps in to local recycling centres free of charge.

In the B2B sector (Business to Business), discharge lamps with mercury residue qualify as waste requiring special supervision (special waste code) with a corresponding duty to dispose of them carefully. This applies for example to mercury vapour lamps and (compact) fluorescent lamps.

In Germany this is, today, regulated by the „Kreislaufwirtschaftsgesetz“ and it's legislation.

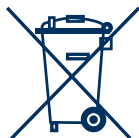

All the above-mentioned lamps affected by the WEEE regulations have a symbol on the packaging showing a dustbin with a line through it.

## 9 European and international standards

### 9.1 Relevant standards

#### 9.1.1 Lamps and caps

OSRAM DULUX® lamps comply with all relevant European and international standards listed in the following table (see also 9.2 Declaration of Conformity).

	German	European	International
Single-capped fluorescent lamps Performance – specifications	DIN EN 60901 (VDE 0715 Teil 7)	EN 60901	IEC 60901
Single-capped fluorescent lamps Safety specifications	DIN EN 61199 (VDE 0715 Teil 9)	EN 61199	IEC 61199
Lamp caps and holders together with gauges for the control of interchangeability and safety	DIN EN 60061	EN 60061	IEC 60061
Part 1: Lamp caps	DIN EN 60061-1	EN 60061-1	IEC 60061-1

#### 9.1.2 Accessories

The following table shows the most important standards that apply to accessories.

	German	European	International
Lamp caps and holders together with gauges for the control of interchangeability and safety	DIN EN 60061	EN 60061	IEC 6061
Part 2: Lampholders	DIN EN 60061-2	EN 60061-2	IEC 60061-2
Part 3: Gauges	DIN EN 60061-3 Band I und II	EN 60061-3	IEC 60061-3
Part 4: Guidelines and general information	DIN EN 60061-4	EN 60061-4	IEC 60061-4
Glow starters for fluorescent lamps	DIN VDE 0712 Teil 101	EN 60 155	IEC 60155
Ballasts for tubular fluorescent lamps General and safety requirements	DIN EN 60 920 (VDE 0712 Teil 10)	EN 60 920	IEC 60920
Ballasts for tubular fluorescent lamps Performance requirements	DIN EN 60 921 (VDE 0712 Teil 11)	EN 60 921	IEC 60921
DC-supplied electronic control gear for tubular fluorescent lamps General and safety requirements	DIN EN 60 924 (VDE 0712 Teil 20)	EN 60 924	IEC 60924
AC-supplied electronic ballasts for tubular fluorescent lamps General and safety requirements	DIN EN 60 928 (VDE 0712 Teil 22)	EN 60 928	IEC 60928
AC-supplied electronic ballasts for tubular fluorescent lamps Performance requirements	DIN EN 60 929 (VDE 0712 Teil 23)	EN 60 929	IEC 60929

	German	European	International
Electromagnetic compatibility (EMC) Section 2: Limits for harmonic currents emissions (Equipment input current $\leq 16A$ per phase)	DIN EN 61000-3-2 (VDE 0838 Teil 2)	EN 61000-3-2	IEC 1000-3-2
Capacitors for use in tubular fluores- cent and other discharge lamp circuits General and safety requirements	DIN EN 61 048 (VDE 0560 Teil 61)	EN 61 048	IEC 1048
Capacitors for use in tubular fluores- cent and other discharge lamp circuits Performance requirements	DIN EN 61049 (VDE 0560 Teil 62)	EN 61 049	IEC 1049

### 9.1.3 Luminaires

The following table shows the most important standards that apply to luminaires.

Suppression of radio disturbances caused by electrical appliances and systems; limits and methods of measurement of radio disturbance characteristics of electrical lighting and similar equipment	DIN EN 55015 VDE 0875 Teil 15	EN 55015	CISPR 15
Equipment for general lighting purposes, EMC immunity requirements	DIN EN 61547	EN 61547	IEC 1547
Luminaires	DIN EN 60598	EN 60598	IEC 598
Part 1: General requirements and tests	DIN EN 60598-1 (VDE 0711 Part 1)	EN 60 598-1	IEC 598-1
Fixed general purpose luminaires purpose luminaires	DIN VDE 0711 Part 201	EN 60 598-2-1	IEC 598-2-1
Recessed luminaires	DIN VDE 0711 Part 202	EN 60 598-2-2	IEC 598-2-2
Luminaires for road and street lighting	DIN EN 60 598-2-3 (VDE 0711 Part 203)	EN 60 598-2-3	IEC 598-2-3
Portable general purpose luminaires	DIN EN 60 598-2-4 (VDE 0711 Part 204)	EN 60 598-2-4	IEC 598-2-4
Floodlights	DIN VDE 0711 Part 205	EN 60 598-2-5	IEC 598-2-5
Luminaires with built-in transformers for filament lamps	DIN EN 60598-2-6 (VDE 0711 Part 206)	EN 60 598-2-6	IEC 598-2-6
Portable luminaires for garden use	DIN EN 60598-2-7 (VDE 0711 Part 207)	EN 60 598-2-7	IEC 598-2-7
Handlamps	DIN VDE 0711 Part 208	EN 60 598-2-8	IEC 598-2-8
Photo and film luminaires (non-professional)	DIN EN 60 598-2-9 (VDE 0711 Part 9)	EN 60 598-2-9	IEC 598-2-9
Portable child-appealing luminaires	DIN EN 60598-2-10 (VDE 0711 Part 210)	EN 60 598-2-10	IEC 598-2-10
Luminaires for stage lighting, television and film studios (outdoor and indoor)	DIN VDE 0711 Part 217	EN 60 598-2-17	IEC 598-2-17

**9.1.3 Luminaires**  
 (continued)

	<b>German</b>	<b>European</b>	<b>International</b>
Luminaires for swimming pools and similar applications	DIN EN 60 598-2-18 VDE 0711 Part 218	EN 60 598-2-18	IEC 598-2-18
Air-handling luminaires (safety requirements)	DIN EN 60 598-2-19 VDE 0711 Part 2-19	EN 60 598-2-19	IEC 598-2-19
Lighting chains	DIN EN 60 598-2-20 VDE 0711 Part 2-20	EN 60 598-2-20	IEC 60598-2-20
Luminaires for emergency lighting	DIN EN 60 598-2-22 VDE 0711 Part 2-22	EN 60 598-2-22	IEC 598-2-22
Luminaires for use in clinical areas of hospitals and health care buildings	DIN EN 60598-2-25 VDE 0711 Part 225	EN 60 598-2-25	IEC 598-2-25
Electrical supply track systems for luminaires	DIN EN 60570 VDE 0711 Part 300	EN 60 570	IEC 60570
Dental equipment Dental operating light	E DIN EN	pr EN ISO ISO 9680	ISO 9680 9680
Specifications for lighting fittings with service voltages below 1000 V	DIN VDE 0710	not yet available	not yet available
General requirements	DIN VDE 0710 Part 1 <sup>1)</sup>	not yet available	not yet available
Special provisions for lamps operated under adverse conditions	DIN VDE 0710 Part 4 <sup>1)</sup>	not yet available	not yet available
Specification rules for flush-fitting signal-light fittings	DIN VDE 0710 Part 11 <sup>1)</sup>	not yet available	not yet available
Luminaires for aquariums	DIN VDE 0710 Part 12 <sup>1)</sup>	not yet available	not yet available
To ball throwing luminaires safety	DIN VDE 0710 Part 13 <sup>1)</sup>	not yet available	not yet available
Luminaires for building-in furniture	DIN VDE 0710 Part 14 <sup>1)</sup>	not yet available	not yet available

<sup>1)</sup> Existing German standard for which there is currently no international counterpart.



9.1.4 Miscellaneous

	German	European	International
International Lamp Coding System (ILCOS) See also 10.1	DIN 49805	–	IEC TS 61231

9.1.5 Sources

Standards can be obtained from

	Publisher	Sales office
DIN Deutsche Normen	DIN Deutsches Institut für Normung e.V. Burggrafenstraße 6 D - 10787 Berlin	Beuth Verlag GmbH D - 10772 Berlin
DIN VDE Normen	DIN Deutsches Institut für Normung e.V. Burggrafenstraße 6 D - 10787 Berlin	Beuth Verlag GmbH D - 10772 Berlin  VDE-Verlag GmbH Bismarckstr. 33 D - 10625 Berlin
IEC Standards	IEC Central Office 3, rue Varembe CH - 1211 Genf	Beuth Verlag GmbH 10772 Berlin  VDE-Verlag GmbH Bismarckstr. 33 D - 10625 Berlin

9.2 Declaration of conformity

**Declaration of Conformity**  
**(Article 10 of Directive 73/23/EEC)**

OSRAM DULUX® compact fluorescent lamps have been developed and manufactured in compliance with the following

- harmonised (Article 5)
- international (Article 6)
- national (Article 7)

EN 60901 Single -ended fluorescent lamps; Function, April 1996  
EN 61199 Single -ended fluorescent lamps; Safety requirements, December 1999

Standards .....  
(Number and date of issue)

in accordance with the provisions of the low-voltage directive of the Council of the European Communities dated February 19, 1973.

Munich, January 1996

.....  
Place and data of issue

**OSRAM**  
Gesellschaft mit beschränkter Haftung  
Hellabrunner Str. 1  
D - 81536 München

*Carsten Jelli*  
.....  
Name and address of the manufacturer  
(company) with signature

This form corresponds to the official version of the „Declaration of Conformity of the Manufacturer“ from CENELEC (European Committee for Electrical Standards) published as an annex to memorandum No. 3, Edition 1, 1990/12.

### 9.3 CE labelling



The CE label on OSRAM DULUX® packaging and on the declarations of conformity indicate compliance with low-voltage guidelines (safety requirements in accordance with EN 61199).

Here are some points to bear in mind about CE labeling:

- The CE label is intended first and foremost for administrative authorities, not end users.
- The CE label is mandatory for the sale of products that can be used independently within the EU.
- It is purely an administrative label. It is not a seal of quality or approval mark.
- The CE label is based on the declaration of conformity issues by manufacturers on their own responsibility. It is not based on testing by a recognised independent inspectorate.
- The CE label acts as a passport. It promotes free trade within Europe.

### 9.4 Energy Efficiency Index

Commission Directive 98/11/EC: Energy labeling for Household Lamps: The EEI (Energy Efficiency Index, e.g. EEI = A), also known as the „energy label“, classifies lamps according to their energy efficiency (it does not relate to luminaires).

Directive 98/11/EC for implementing Directive 92/75/EEC has been in force since April 1998.

The seven classes are defined by certain limit values in lamp output. Lamps in class A are the most efficient at converting electrical into light.

The classification of OSRAM DULUX® lamps is given in the OSRAM Lighting Programme.

**10. Manufacturers of accessories**

**10.1 Manufacturers of lampholders**

Bender & Wirth GmbH & Co  
Volmestraße 161  
D-58566 Kierspe 1  
Tel.: 0 23 58/66 90  
Fax: 0 23 59/66 91 86  
www.bender-wirth.com

Brökelmann, Jaeger und Busse GmbH & Co  
Postfach 1380  
Werlerstraße 1  
D-59755 Arnsberg 1  
Tel.: 0 29 32/98 20  
Fax: 0 29 32/98 24 01  
www.bjb.de  
info@bjb.de

Hermann Mellert GmbH & Co KG  
Pforzheimerstraße 60  
D-75013 Bretten  
Tel.: 0 72 52/50 50  
Fax: 0 72 52/5 05 10

Metalluk Bauscher GmbH & Co KG  
Ohmstraße 8  
D-96050 Bamberg  
Tel.: 09 51/91 61 50  
Fax: 09 51/13 11 49

VLM Murjahn GmbH  
Am Korreshof 15–17  
D-40822 Mettmann  
Tel.: 0 21 04/1 40 10  
Fax: 0 21 04/1 40 19

Kurt Albert Röhr  
Erasmusstraße 18–19  
D-10553 Berlin  
Tel.: 030/3 44 10 30  
Fax: 030/3 45 43 83

Vossloh-Schwabe GmbH  
Steinwerthstraße 4  
Postfach 1860  
D-58778 Werdohl  
Tel.: 0 23 92/520  
Fax: 0 23 92/5 23 84  
www.vossloh-schwabe.com

A.A.G. Stucchi S.p.A.  
Via IV Novembre 30/32  
I-23854 Olginate (Lecco)  
Tel.: +39/341/65 31 11  
Fax: +39/341/65 32 50  
www.aagstucchi.it  
info@aagstucchi.it

**10.2 Manufacturers of control gear**

**Germany**

OSRAM GmbH  
Hellabrunner Straße 1  
D-81536 Munich  
Tel.: 089/62 13-0  
Fax: 089/62 13-20 20  
www.osram.de  
webmaster@osram.de

ABB Brown Boveri  
Impexstraße 5  
D-63322 Rödermark  
Tel.: 0 62 27/60 50  
Fax: 0 62 27/60 52 55  
www.abb.com

Helvar GmbH  
Carl-Zeiss-Straße 12  
D-63322 Rödermark  
Tel.: 0 60 74/9 20 90  
Fax: 0 60 74/92 09 23  
www.helvar.com

HÜCO Elektronik GmbH  
Von dem Busche-Münch-Straße 12  
Postfach 1228  
D-32326 Espelkamp  
Tel.: 0 57 72/56 70  
Fax: 0 57 72/5 67 10  
www.hueco.com

May & Christe GmbH  
Hauptstraße 204  
D-63814 Mainaschaff

Tel.: 0 60 21/70 60  
Fax: 0 60 21/70 61 72  
www.maychriste.de  
verkauf@maychriste.de

Stengel GmbH  
Hanns-Martin-Schleyer-Straße 25  
D-47877 Willich

Tel.: 0 21 54/91 15 75  
Fax: 0 21 54/91 15 73  
www.stengel.de  
info@stengel.de

Trilux-Lenze GmbH + Co KG  
Heidestraße 4  
D-59759 Arnsberg Hüsten

Tel.: 0 29 32/96 96-0  
Fax: 0 29 32/96 96-20  
www.trilux.de  
arnsberg@trilux.de

Vossloh Schwabe GmbH & Co  
Werk Urbach  
Wasenstraße 25  
D-73660 Urbach

Tel.: 0 71 81/8 00 20  
Fax: 0 71 81/80 02 22

Zenit Energietechnik GmbH  
Bouchestraße 12  
D-12435 Berlin

Tel.: 030/53 31 23 95  
Fax: 030/53 31 23 94  
www.zenit-energietechnik.de  
mail@zenit-energietechnik.de

## England

Orbik House  
Northgate Way  
Aldridge, Walsall  
GB-WS9 8TH West Midlands  
United Kingdom

Tel.: +44/922/74 35 15  
Fax: +44/922/74 31 73  
orbik@aldridge98.freemove.co.uk

W.J. Parry Ltd.  
Victoria Mills  
Draycott  
Derby  
GB-DE7 3PW  
United Kingdom

Tel.: +44/1332/87 23 21  
Fax: +44/1332/87 40 35  
www.parry.co.uk

Thorn Lighting Ltd.  
Spennymoor  
Co. Durham  
GB-DL16 7UR  
United Kingdom

Tel.: +44/388/42 00 42  
www.thornlighting.com  
info@thorn.com

Transtar Ltd.  
Victoria Trading Estate  
Victoria Rd. West  
Hebburn  
Tyne & Wear  
GB-NE31 1 UB  
United Kingdom

Tel.: +44/91/4 83 27 97  
Fax: +44/91/4 28 02 62

## Finland

Helvar OY  
Purotie 3, P. O Box 55  
FIN-00380 Helsinki

Tel.: +358/9/5 65 41  
Fax: +358/9/56 54 96 00  
www.helvar.com  
info@helvar.com

---

<b>Italy</b>	Beghelli s.r.l. Via Mozzeghine, 13-15 I-40050 Monteveglio (BO) Italia	Tel.: +39/051/83 84 11 Fax: +39/051/83 84 44 www.beghelli.it italia@beghelli.it
	ERC SPA Via dei Sassi 2 I-23801 Caloziocorte (LC) Italia	Tel.: +39/341/63 73 11 Fax: +39/341/63 73 00 www.erc.it erc@erc.it
<b>Norway</b>	Glamox A/S Faunestrandsveien 62 N-6400 Molde Norge	Tel.: +47/7/24 60 00 Fax: +47/7/24 60 01 www.glamox.com
<b>Austria</b>	Tridonic Atco GmbH & Co KG Färbergasse 15 A-6851 Dornbirn Austria	Tel.: +43/55 72/395-0 Fax: +43/55 72/2 01 76 www.tridonicatco.com sales@tridonic.co.at
<b>Switzerland</b>	BAG Turgi Elektronik AG P.O. Box 227 CH-5300 Turgi	Tel.: +41/562/01 04 88 Fax: +41/562/01 04 99 www.bagturgi.com mail@bagturgi.com
	F. Knobel AG Postfach CH-8755 Enneda	Tel.: +41/55/6 45 47 47 Fax: +41/55/6 45 47 00 www.knobelag.ch
	Leuenberger AG Kaiserstuhlstraße 44 CH-8154 Oberglatt	Tel.: +41/1/18 52/10 20 Fax: +41/1/850/59 85 www.ltl.ch info@ltl.ch
	Starkstrom-Elektronik Güterstraße 11 CH-8957 Spreitenbach	Tel.: +41/0/5 64 18 78 00 Fax: +41/0/5 64 01 49 86 www.se-ag.ch info@se-ag.ch

### 10.3 ECG manufacturers DC/emergency operation

#### Germany

OSRAM GmbH  
Hellabrunner Straße 1  
D-81536 Munich

Tel.: 089/62 13-0  
Fax: 089/62 13-2020  
www.osram.de  
webmaster@osram.de

Eckerle Industrie-Elektronik GmbH  
Benzstraße 12 a  
D-76316 Malsch

Tel.: 0 72 46/9 20 40  
Fax: 0 72 46/92 04 44  
www.eckerle.com  
info@eckerle.com

Präzisa Industrieelektronik GmbH  
Lanterstraße 34  
D-46539 Dinslaken

Tel.: 0 20 64/9 70 10  
Fax: 0 20 64/97 01 66  
www.praezisa.de  
kontakt@praezisa.de

Stengel GmbH  
Hanns-Martin-Schleyer-Straße 25  
D-47877 Willich-Münchheide II

Tel.: 0 21 54/91 15 75  
Fax: 0 21 54/91 15 73  
www.stengel.de  
info@stengel.de

Zenit Energietechnik GmbH  
Wilsnacher Straße 40  
D-10559 Berlin

Tel.: 030/3 94 11 80  
Fax: 030/39 11 75  
www.zenit-energietechnik.de  
mail@zenit-energietechnik.de

This list is provided as a guide to accessory manufacturers for OSRAM DULUX compact fluorescent lamps. We make no claims that it is either complete or correct. **We therefore take no responsibility for the availability, suitability or quality of equipment or products from the named manufacturers.**

Subject to change without notice.  
Printed on paper treated with chlorine-free bleach.







