

修 订	标 记	修 改 描 述	签 名	日 期
REV NO		NEW DRG		2016-03-12

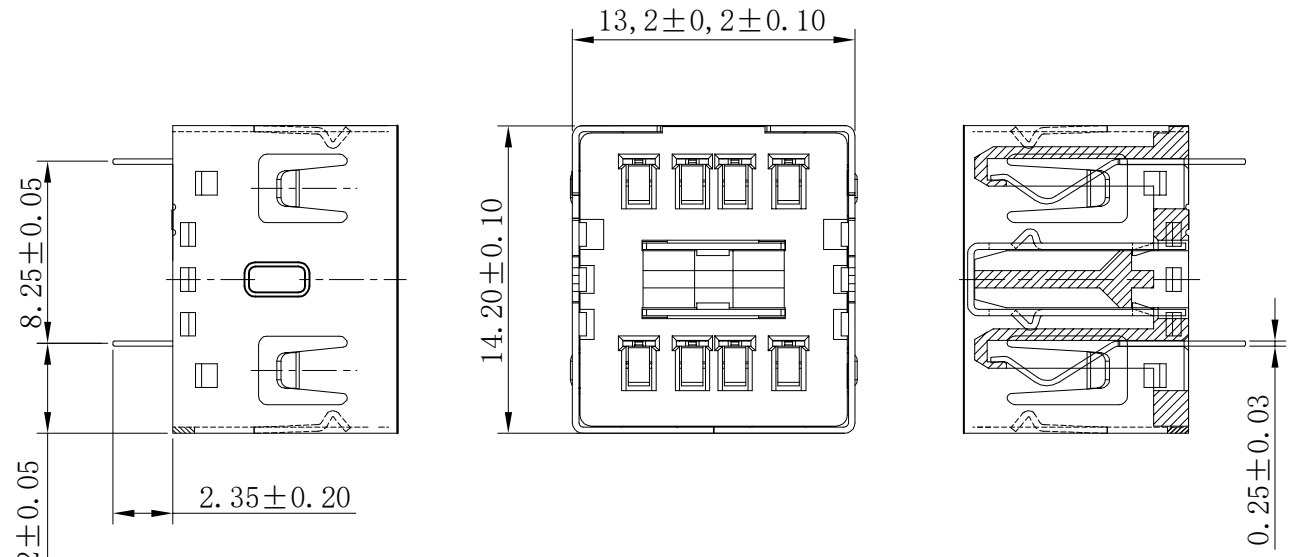

- SPECIFICATIONS:
- ELECTRICAL CHARACTERISTICS:
    - CURRENT RATING: 1.8A (PIN1,4) ; OTHER CONTACTS 0.25A
    - CONTACT RESISTANCE: 30mΩ MAX.
    - DIELECTRIC WITHSTANDING VOLTAGE: 100V AC FOR 1 MINUTE
    - INSULATION RESISTANCE: 100MΩ MIN
  - MECHANICAL CHARACTERISTICS:
    - INSERTION FORCE : 1.0~3.57 Kgf
    - WITHDRAWAL FORCE : 1.0~3.57 Kgf
  - DURABILITY: 1500 CYCLES.
  - TO CONFORM TO SINGATRON HAZARDOUS SUBSTANCE FREE SPEC.
  - HALOGEN PRODUCT IDENTIFICATION LABEL ON PACKAGING:

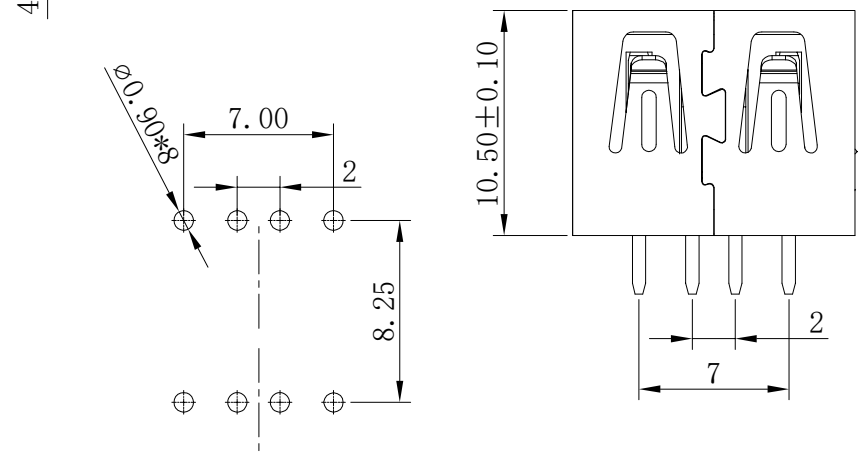

Recommended P.C.B Layout  
 TOLERANCE = ±0.05 THICKNESS = 1.0mm

REMARK	Pin Number	Signal ASSIGNMENT
USB2.0 CONTACT PIN	PIN 1	VBUS
	PIN 2	D-
	PIN 3	D+
	PIN 4	GND

NO	DESCRIPTION	QTY	MATERIAL	PLATING & COLOR
D	MID SHELL	1	SPCC T=0.30	NICKEL 60u"MIN
C	TERMINAL	8	C2680 T=0.25	G/F ON MATING AREA, 100u"MIN TIN PLATED ON SOLDERING 50u" NICKEL UNDER PLATING OVERALL
B	SHELL	1	SPCC T=0.30	NICKEL 60u"MIN
A	HOUSING	1	PBT UL94-V0	White

**HDC** 深圳市华德共创科技有限公司  
 Shenzhen Huade co-create Technology Co., LTD  
 电话: 0755-23304126 传真: 0755-29940187

-TOLERANCES- UNLESS OTHERWISE SPECIFIED 公差参数表		TITLE: 产品名称: USB AF10.5双层平口白胶	
X.X ±0.30	X.X* ±3°	APPD: 核准:	PART NO: 产品编号: USB-HXS-104DIP
X.XX ±0.20	X.XX* ±2°	CHECK: 校对: 王建业	DATE
X.XXX ±0.10	X.XXX* ±1°	DRAW: 绘图: 黄艳兰	SCALE
			UNIT
			CODE NUMBER
		2016-03-12	1:1
			mm
			A001

由 Autodesk 教育版产品制作

由 Autodesk 教育版产品制作