

## ZW12-B 型微动开关系列 Micro switch series

### ◆ 安全可靠的小型開關 Safe, reliable miniature switch

- 外形美觀，結構緊湊。具有微小觸點間隙，快速動作、高靈敏和微小動作行程的特點。

Nice appearance, tight configuration. Characteristic: small contact clearance, quick action, high sensitivity and small operating travel.

- 長壽命，高可靠。

Long life, high reliability.

- 接綫端子種類齊全

Variety of contact terminals

- 動作力範圍寬

A variety of models with low operating force to high operating force are available

- 多種溫度等級

Variety of temperature degrees

- 配備各種形式動臂

Variety of levers

- 採用熱固性或熱塑性塑料

Adopt thermosetting plastic or thermoplastic

- 廣泛應用於各種家用電器、電子設備、自動化設備、通訊設備、汽車電子、儀器儀表、電動工具等領域。

Widely used in appliance, electronic equipment, automatic machine, communication equipment, car electric, apparatus and instrument, electric motion tool etc.

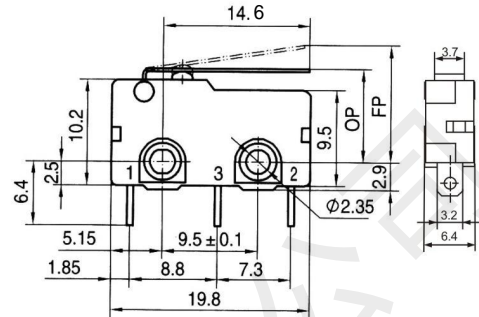

### ◆ 技術特性 Specifications

項目 Item	特性值 Value
工作速度 Operating speed	0.1mm ~ 1m/s (與驅動方式有關)(Related with actuator forms)
工作頻率 Operating Frequency	機械 60次/min; 電氣 25次/min Mechanical 60 cycles/min; Electrical 25cycles/min
絕緣電阻 Insulation resistance	≥ 100MΩ (500VDC)
接觸電阻 Contact resistance	≤ 30mΩ (初始值)(Initial value)
耐電壓 Test voltage	同極不相接端子間 Between terminals of the same polarity
	帶電金屬零件與地(外殼)之間、接綫端與不帶電金屬件之間 Between current-carrying metal parts and ground (case), and between each terminal and non-current-carrying metal parts.
抗振動 Vibration resistance	10 ~ 55Hz, 1.5mm 兩倍振幅 Double amplitude
抗衝擊 Shock resistance	破壞: 動作力 > 0.5N: 1000m/s <sup>2</sup> (約 100G) max 動作力 ≤ 0.5N: 400m/s <sup>2</sup> (約 40G) max 故障: 動作力 > 0.5N: 200m/s <sup>2</sup> (約 20G) max 動作力 ≤ 0.5N: 100m/s <sup>2</sup> (約 10G) max Destruction: OF > 0.5N: 1000m/s <sup>2</sup> (approx. 100G) max OF ≤ 0.5N: 400m/s <sup>2</sup> (approx. 40G) max Malfunction: OF > 0.5N: 200m/s <sup>2</sup> (approx. 20G) max OF ≤ 0.5N: 100m/s <sup>2</sup> (approx. 10G) max
壽命 Life expectancy	機械 ≥ 1000000次; Mechanical ≥ 1000000 cycles 電氣 ≥ 100000次; Electrical ≥ 100000cycles
質量 Weight	約 1.6g (無動臂型) Approx. 1.6g (No lever)



深圳市首韩科技有限公司

SHENZHEN SHOUHAN TECHNOLOGY CO., LTD

Tel: 0755-27597601 Fax: 0755-27597491

# 承 认 书

## SPECIFICATION FOR APPROVAL

客 户 Customer:

\_\_\_\_\_

产品名称 Project:

微动开关

\_\_\_\_\_

规格型号 Part No:

ZW12-B

\_\_\_\_\_

### 贵公司承认印 Approval signatures

料 号/Part No.	签 章/Signatures

日期 Date:

拟制/Drawn	李春风	
审核/Check	钟华华	
批准/Approved	罗孝金	