

**Surface Mount Schottky Barrier Rectifier**  
**Reverse Voltage - 20 to 200 V**  
**Forward Current - 1.0 A**

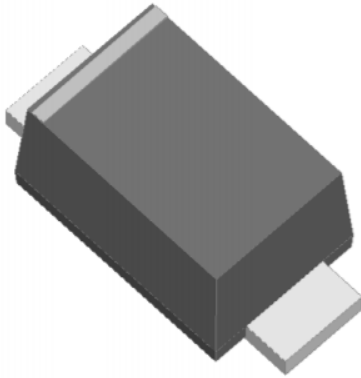

**FEATURES**

- Metal silicon junction, majority carrier conduction
- For surface mounted applications
- Low power loss, high efficiency
- High forward surge current capability
- For use in low voltage, high frequency inverters, free wheeling, and polarity protection applications

**MECHANICAL DATA**

- Case: SOD-123FL
- Terminals: Solderable per MIL-STD-750, Method 2026
- Approx. Weight: 15mg 0.00048oz

**Absolute Maximum Ratings and Electrical characteristics**

Ratings at 25 °C ambient temperature unless otherwise specified. Single phase, half wave, 60Hz resistive or inductive load, for capacitive load, derate by 20 %

Parameter	Symbols	K12	K14	K16	K18	K110	K112	K115	K120	Units
Maximum Repetitive Peak Reverse Voltage	$V_{RRM}$	20	40	60	80	100	120	150	200	V
Maximum RMS voltage	$V_{RMS}$	14	28	42	56	70	84	105	140	V
Maximum DC Blocking Voltage	$V_{DC}$	20	40	60	80	100	120	150	200	V
Maximum Average Forward Rectified Current	$I_{F(AV)}$	1.0								A
Peak Forward Surge Current, 8.3ms Single Half Sine-wave Superimposed on Rated Load (JEDEC method)	$I_{FSM}$	30								A
Max Instantaneous Forward Voltage at 1 A	$V_F$	0.55	0.70		0.85		0.90		V	
Maximum DC Reverse Current $T_a = 25^{\circ}C$ at Rated DC Reverse Voltage $T_a = 100^{\circ}C$	$I_R$	0.3 10			0.2 5		0.1 2		mA	
Typical Junction Capacitance <sup>(1)</sup>	$C_j$	110	80							pF
Typical Thermal Resistance <sup>(2)</sup>	$R_{\theta JA}$	100								$^{\circ}C/W$
Operating Junction Temperature Range	$T_j$	-55 ~ +150								$^{\circ}C$
Storage Temperature Range	$T_{stg}$	-55 ~ +150								$^{\circ}C$

( 1 ) Measured at 1 MHz and applied reverse voltage of 4 V D.C

( 2 ) P.C.B. mounted with 2.0" X 2.0" (5 X 5 cm) copper pad areas.

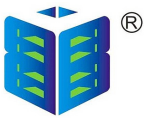

Fig.1 Forward Current Derating Curve

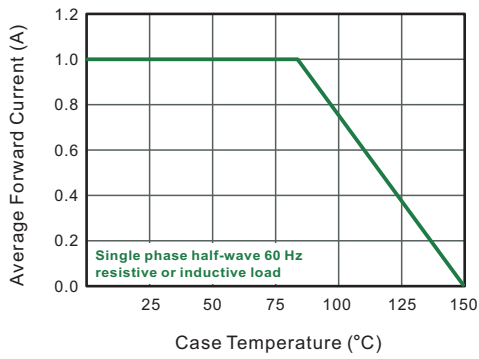

Fig.2 Typical Reverse Characteristics

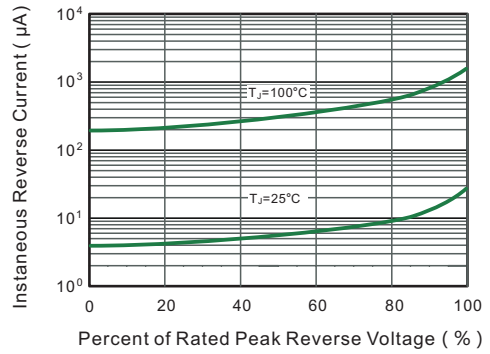

Fig.3 Typical Forward Characteristic

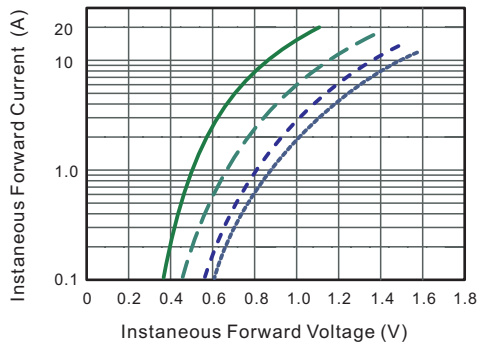

Fig.4 Typical Junction Capacitance

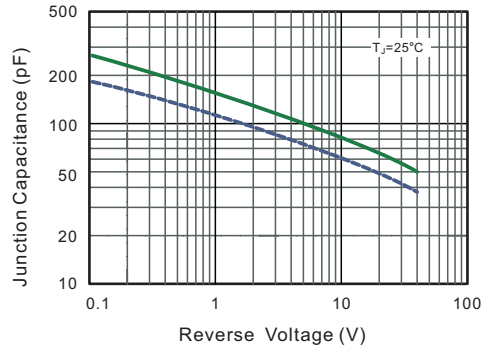

Fig.5 Maximum Non-Repetitive Peak Forward Surge Current

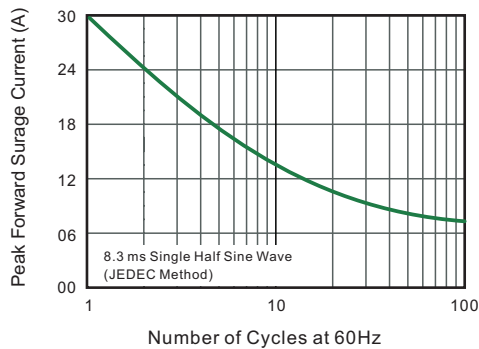
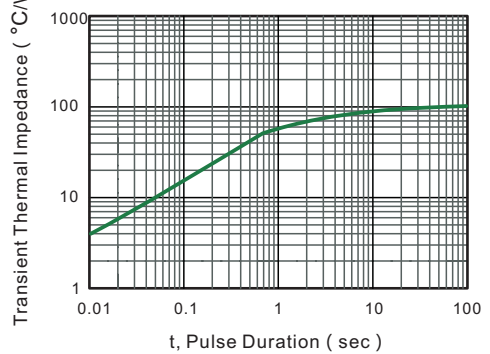
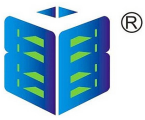

Fig.6- Typical Transient Thermal Impedance





Plastic surface mounted package; 2 leads

SOD-123FL

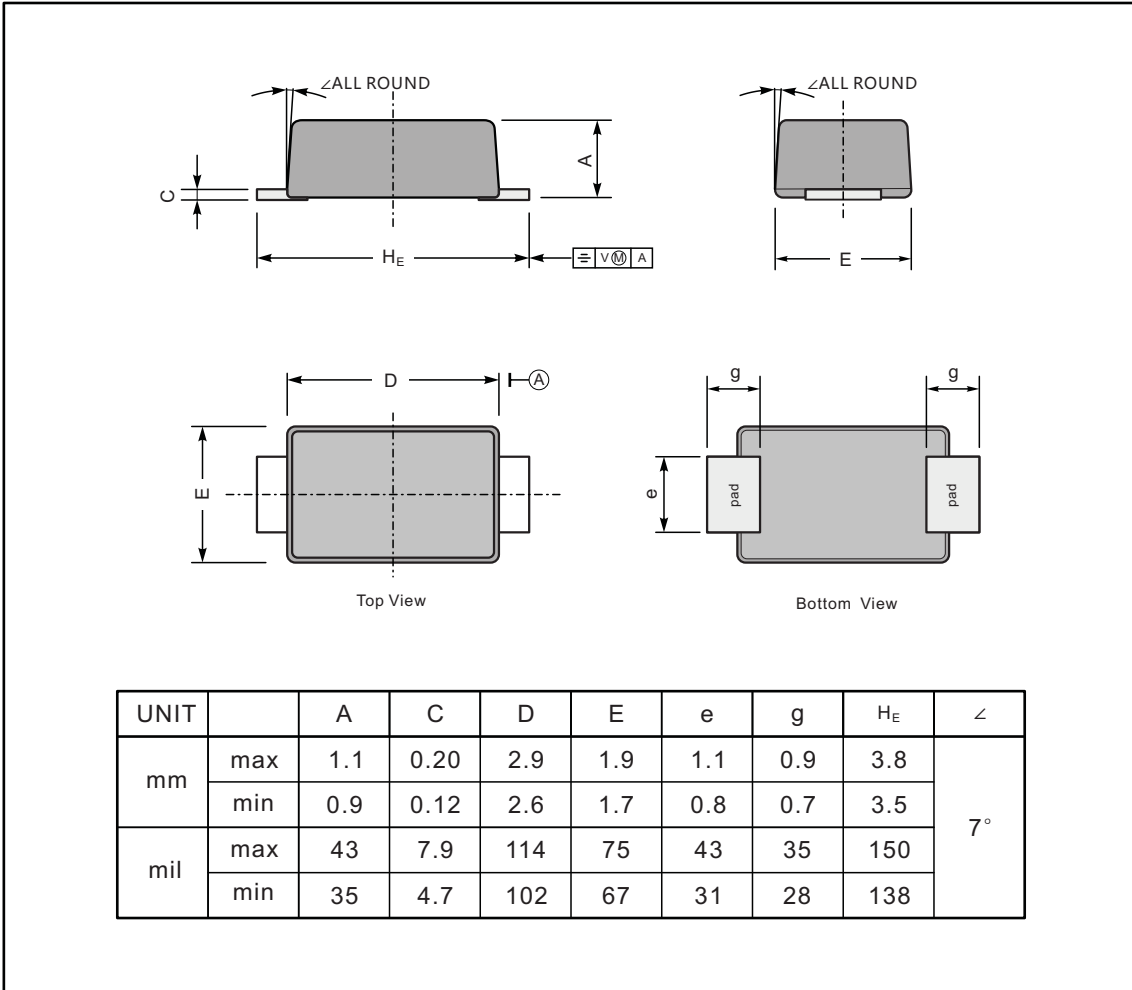

The recommended mounting pad size

