

■ Features

- Molding Inductor.
- Low Profile,Low Temp.
- Large Current(Over 15A).
- Customize For Different Need.
- Operating temperature:-40℃ ~ +125℃.

■ Applications

- General Electronic.
- Video Device,TV,TFT.
- Power Module for PC.
- NB/Lap Top Computer.
- Server,VGA Card/Module.

■ Product Identification

YSPIA
□□□□
-
□□□
□

(1)
(2)
(3)
(4)

(1) : Type

(2) : Dimensions

(3) : Inductance value

(4) : Inductance Tolerance : N=±30%,M=±20% , K=±10%

■ Shapes and Dimensions (Unit: mm)

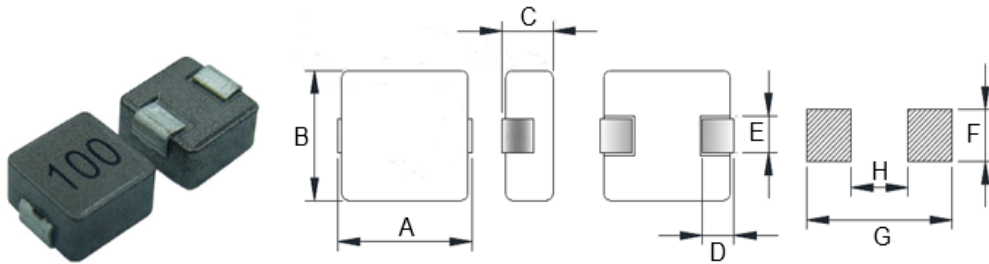

| TYPE | A | B | C Max. | D | E | F Ref. | G Ref. | H Ref. |
|-----------|---------|---------|--------|---------|---------|--------|--------|--------|
| YSPIA0320 | 3.4±0.5 | 3.0±0.2 | 2.0 | 0.6±0.3 | 1.0±0.3 | 1.2 | 4.2 | 1.0 |

■ YSPIA0320 Series

| Part Number | Inductance (uH) @100KHz | DC Resistance (mΩ) | | Heat Rating Current (A) | Saturation Current (A) |
|----------------|----------------------------|--------------------|------|----------------------------|---------------------------|
| | | Typ. | Max. | | |
| YSPIA0320-R10□ | 0.10 | 7 | 9 | 11.0 | 14.0 |
| YSPIA0320-R33□ | 0.33 | 14 | 17 | 8.0 | 10.0 |
| YSPIA0320-R47□ | 0.47 | 20 | 23 | 7.0 | 9.0 |
| YSPIA0320-R68□ | 0.68 | 26 | 29 | 5.5 | 7.0 |
| YSPIA0320-R88□ | 0.88 | 29 | 35 | 4.5 | 6.0 |
| YSPIA0320-1R0□ | 1.00 | 32 | 38 | 4.0 | 5.0 |
| YSPIA0320-1R2□ | 1.20 | 39 | 45 | 4.0 | 4.5 |
| YSPIA0320-1R5□ | 1.50 | 48 | 58 | 3.8 | 4.0 |
| YSPIA0320-2R2□ | 2.20 | 65 | 75 | 3.5 | 3.7 |
| YSPIA0320-3R3□ | 3.30 | 125 | 145 | 3.0 | 3.5 |

- ※ The saturation current value is the DC current value having inductance decrease down to 30%.(at 20°C)
- ※ The temperature rise current value is the DC current value having temperature increase up to 40°C. (at 20°C)
- ※ The rated current is the DC current value that satisfies both of current value saturation current value and temperature rise current value.

■ Taping Dimensions(Unit:mm)

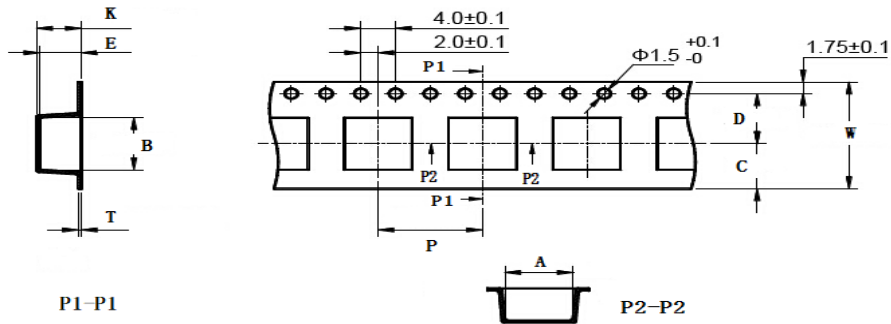

| TYPE | W | A | B | C | D | E | P | K Ref | T | MPQ |
|-----------|--------|---------|---------|------|---------|---------|-------|-------|-----------|------|
| YSPIA0320 | 12±0.3 | 3.3±0.1 | 3.7±0.1 | 4.75 | 5.5±0.1 | 2.1±0.1 | 8±0.1 | 2.2 | 0.30±0.05 | 1000 |

■ Reel Dimensions(Unit:mm)

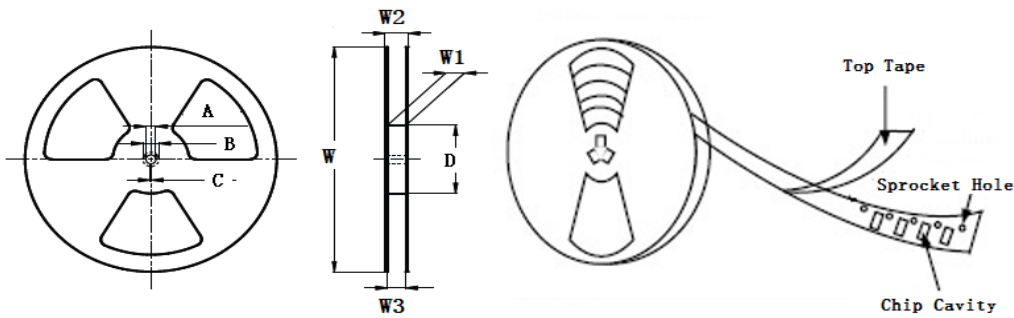

| TYPE | W | W1 | W2 | W3 | A | B | C | D |
|-----------|---------|-----------|---------|----------|-----------|-----------|----------|--------|
| YSPIA0320 | 178±2.0 | 12.4±1.50 | 18.4MAX | 11.9 Min | 13.0±0.50 | 21.0±0.80 | 2.0±0.50 | 60 Min |

■ Direction of rolling

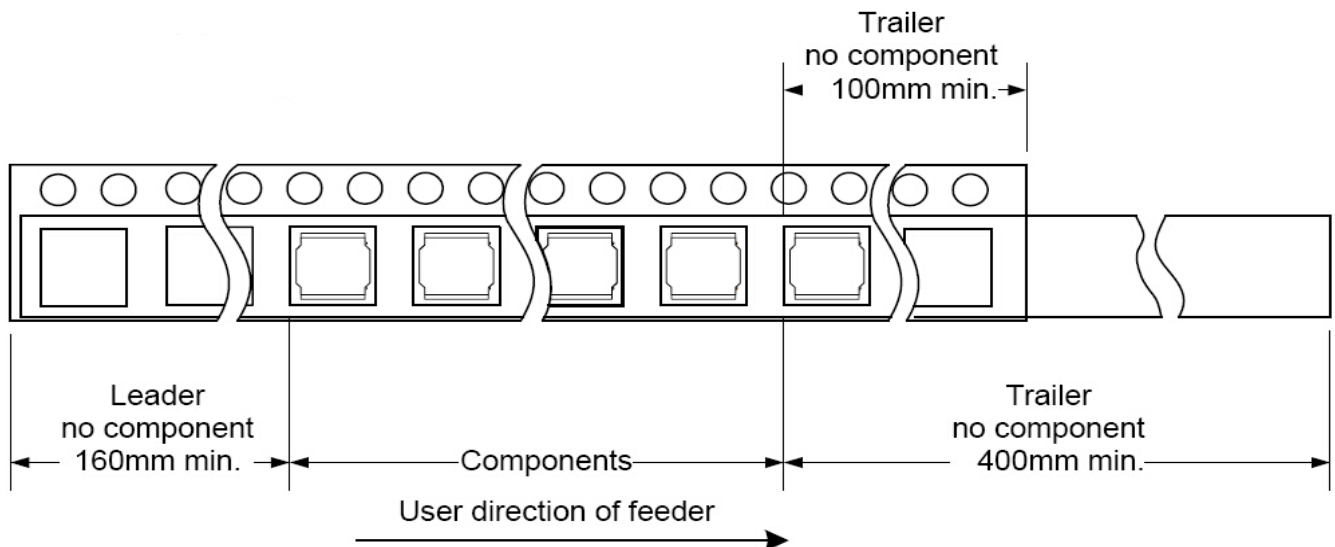

■ Cover tape peel off condition

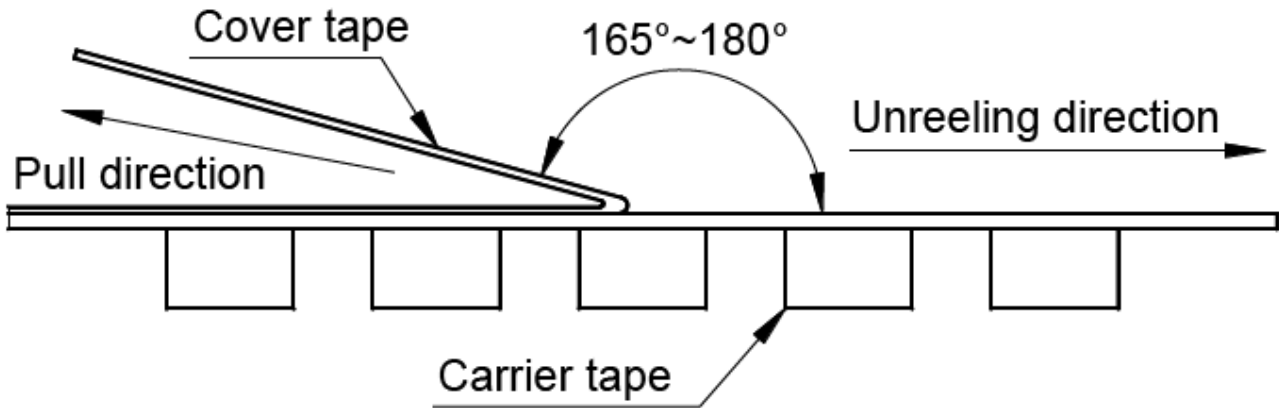

Cover tape peel force shall be 0.1N to 1.3N.

Reference peel speed 300±10mm/min.