



产品规格书 SPECIFICATION

客户名称: _____

Customer Name

产品类型: 红外接收头

Product Name

产品型号: ZSIRM-Z5PK81

Part No.

<input type="checkbox"/> 技术参考 Technical Reference		<input type="checkbox"/> 样品 Sample		<input type="checkbox"/> 量产供货 Mass Product	
客户审核 (加盖公章) Client approval (Stamp)			洲光源审核 Chaulight approval		
核准 Approval	确认 Checked	核准 Approval	确认 Checked	制作 Edited	
		谢小金	杨培续	赖华棋	
<input type="checkbox"/> 接收 Qualified		<input type="checkbox"/> 不接收 Disqualified		日期 Date: 2020.08.14	

联系电话(Tel): 13828819291

E-mail: tony@zgy-led.com

地址(Add): 深圳市宝安区航城街道航空路 36 号华盛泰科技大厦 D 栋 502

No.502, Building D, Huashengtai Science and Technology Building, No. 36, Hangcheng Street, Bao'an District, Shenzhen

本规格书仅用于双方交流用需经双方签订后方可生效, 自签订后有效期为两年, 期满后需以书面形式续签。最终解释权为洲光源所有。

This product specification is only used for technical communication. Only after the signature or seal, the specifications have the force of law. since the signing of the validity period of two years, after the expiration of the written renewal. The final interpretation right is owned by the CHAULIGHT

ZSIRM-Z5PK81 是一种红外接收器，用于远程控制和其他需要改进环境光抑制的应用。单独的 PIN 二极管和前置放大器 IC 电路组装在单个引线框架上。环氧树脂包装包含一个特殊的红外过滤器。该模块即使在受干扰的环境光应用中也具有良好的性能，并提供保护，防止不受控制的输出脉冲。

The ZSIRM-Z5PK81 is infrared receivers for remote control and other applications requiring improved ambient light rejection.

The separate PIN diode and preamplifier IC are assembled on a single leadframe.

The epoxy package contains a special IR filter.

This module has excellent performance even in disturbed ambient light applications and provides protection against uncontrolled output pulses.

特性 Feature

--光电探测器和前置放大器放在一个包中

Photo detector and preamplifier in one package

--PCM 频率的内部滤波器

Internal filter for the PCM frequency

对环境光的高免疫力

High immunity against ambient light

改进了对电场干扰的屏蔽能力

Improved shielding against electric field disturbance

4.5 伏供电电压；低功耗

4.5-Volt supply voltage; low power consumption

TTL 和 CMOS 兼容性

TTL and CMOS compatibility

应用 Application

--电视,录像机,音响设备,空调,汽车立体声收音机,玩具,家庭电脑,所有需遥控设备

TV, VCR, audio equipment, air conditioning, car stereo radio, toys, home computer, all require remote control equipment

最大额定值 Absolute Maximum Ratings

测试项目 Parameter (Ta=25°C)	符合 Symbol	范围 Ratings	单位 Unit
电源电压 Supply voltage	Vcc	0~6	V
工作温度 Operating Temperature	Topr	-20~+80	°C
储存温度 Storage Temperature	Tstg	-40~+125	°C
焊接温度 Lead Soldering Temperature*3	Tsol	260 (<5s)	°C

*1、在 25 摄氏度的环境中测试 below 25 Free Air Temperature

*2、脉宽少于等于 100us，占空比 1% Pulse width \leq 100 μ s, Duty cycle= 1%

*3、离胶体 2.5mm 以上焊接 5s 内 2.5mm form body for 5 seconds

光电特性 Electro-Optical Characteristics

电性参数 (温度=25℃) Parameter (Ta=25℃)	符号 Symbol	条件 Condition	最小值 Min.	典型值 Typ.	最大值 Max.	单位 Units
工作电压 working voltage	Vcc	--	2.7	--	6.0	V
静态电流 Supply Current	Icc	Vcc=5.0v	0.30	0.60	1.00	mA
载波频率 B.P.F. Center Frequency	fo	--	--	37.9	--	kHz
峰值波长 Peak Wavelength	λ_p	--	--	940	--	nm
低电平输出 Low Level Output Voltage	Vol	--	--	0.20	0.40	mV
高电平输出 High Level Output Voltage	Voh	Vcc=5.0v	4.80	5.00	--	V
脉冲宽度 pulse width	Tpw	--	450	--	750	μ S
接收距离 Arrival Distance	L1	($\theta = 0^\circ$)	12	--	--	m
	L2	($\theta = 45^\circ$)	6	--	--	m
半角 Half angle	$2\theta_{1/2}$	--	--	± 45	--	Deg

方框图 Block Diagram

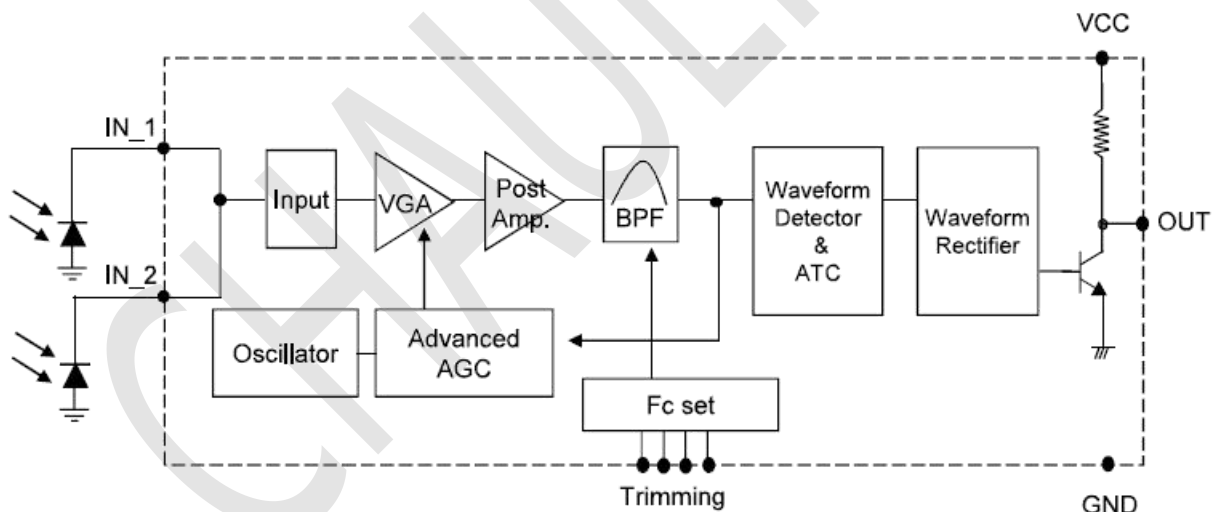

试验方法 Test Method

A. Standard Transmitter

ON/OFF pulse width satisfied from 25 cm to detection limit

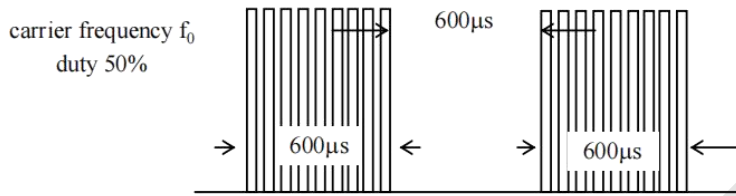

Fig 1. Burst Wave

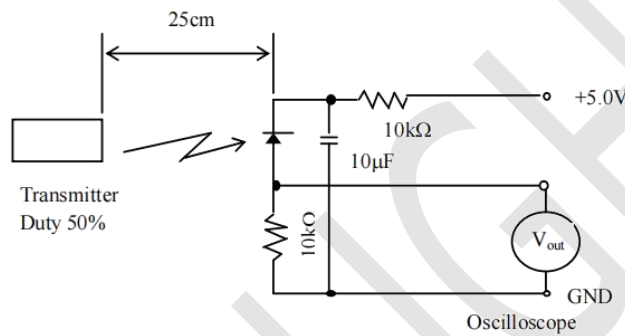
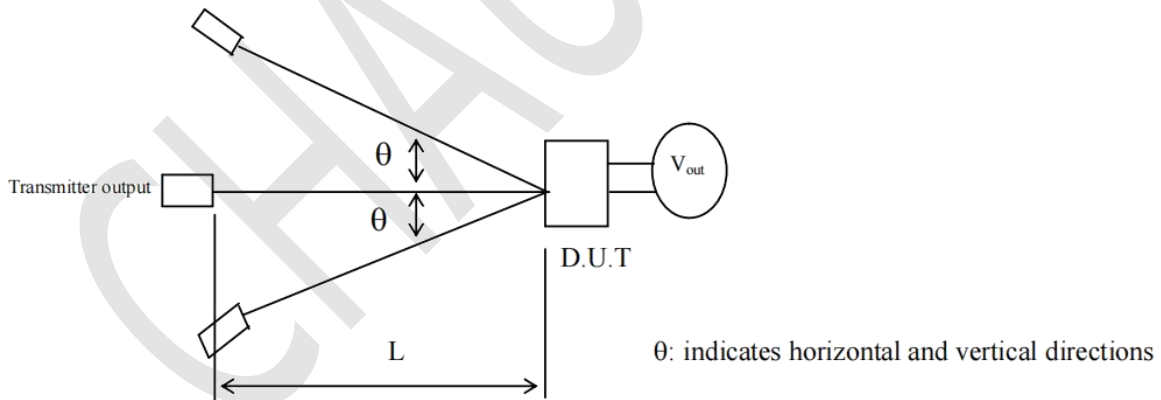
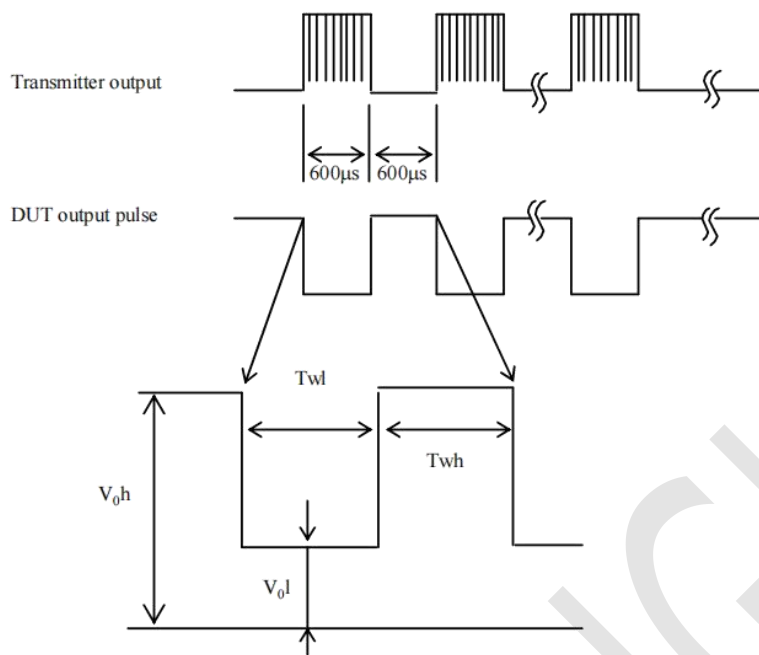

Fig 2. Standard Transmitter Measurement circuit

B. Detection Length Test



C . Pulse Width Test



应用电路 Application Circuit

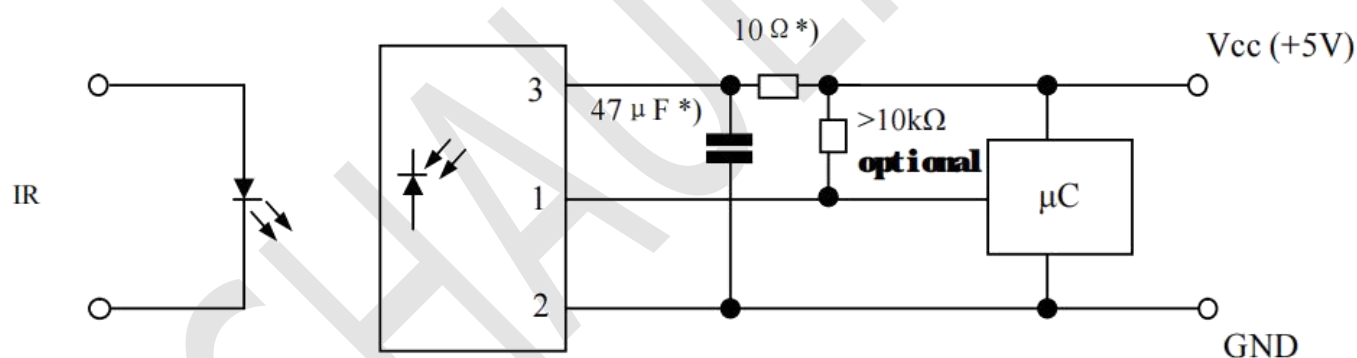

*) recommended to suppress power supply disturbances

代码信息 Code information

Item	Symbol	limitation
Minimum burst length	t_{Burst}	Sony 15 Bit
Minimum gap time after each burst	t_{Gap}	Sony 20 Bit
Minimum pause time in the data stream	t_{Pause_min}	Toshiba
Required data pause time	$t_{pause} > (Data\ word\ length / 3) + 18.5ms$	
Data Format	NEC&Toshiba Code	Yes
	RC5 / RC6 Code	Yes
	Sony 12bit Code	Yes
	Sony 15bit / 20bit Code	No
	XMP / RCMM Code	No

note 1): t_{Pause_min} Could be changed by different data word format . Therefore , for new application on sets please refer to Required data pause time (pause) on above.

典型光电特性曲线图 Typical Electro-Optical Characteristics Curves

不同电压与静态电流关系

Relation between different voltages and static current

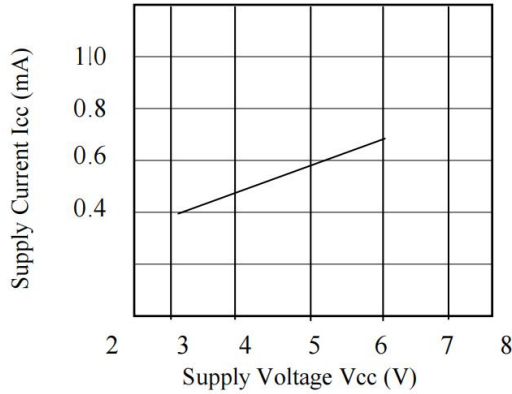

输入脉冲宽度与距离

Input pulse width and distance

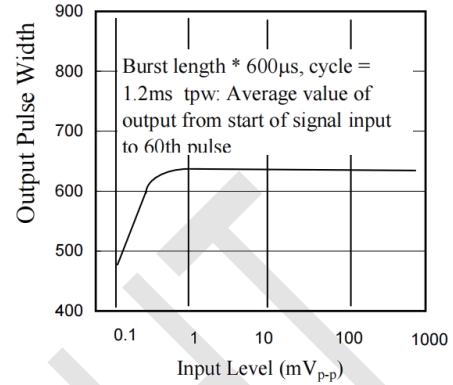

频率相关性响应性

FREQUENCY DEPENDENCE OF RESPONSIVITY

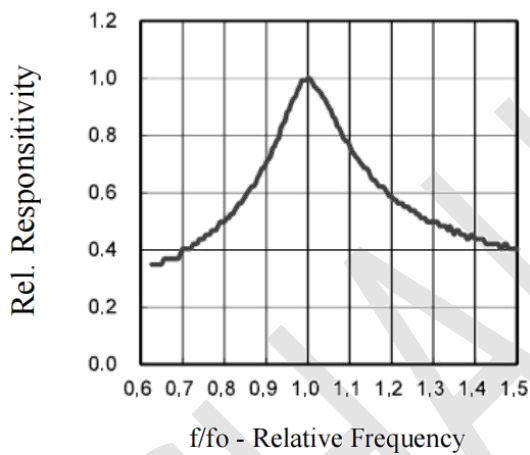

波长曲线图

Spectral Distribution

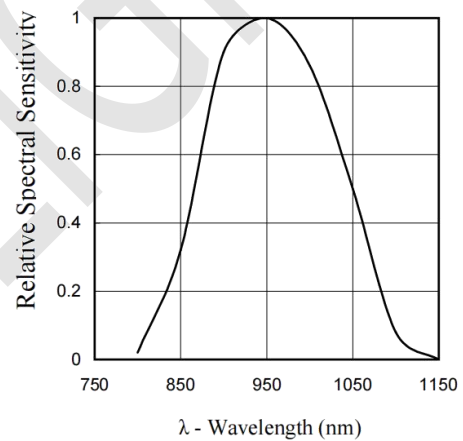

相对光强度与角位移的关系

Relative Light Intensity vs. Angular Displacement

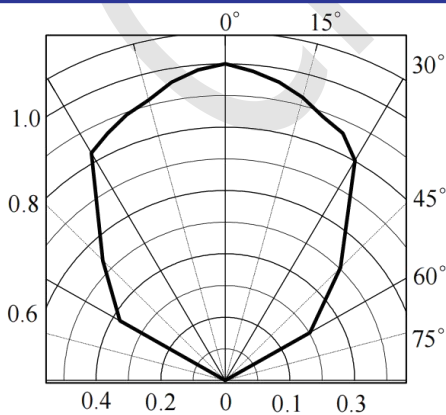

可靠性 Reliability

测试项目 Test item	测试条件 Test condition	适用 Standard
高温 High temperature	Ta=+80°C t=48H	Note 2
寿命测试 Life Test	V _{CC} =5V t=500H	Note 2
低温 Low temperature	Ta=-30°C t=48H	Note 2
温度循环 Temperature cycle	-35°C(0.5H)~+85°C(0.5H) 20cycle	Note 2
跌落 Dropping	Test devices shall be dropped 3 times naturally onto hard wooden board from a 75cm height position.	Note 2
焊接能力测试 Soldering ability test	Ta=260°C t=5s	Note 3

NOTE 1. Distance between emitter & detector specifies maximum distance that output wave form satisfies the standard under the conditions below against the standard transmitter .

1)Measuring place : Indoor without extreme reflection of light .

2)Ambient light source: Detecting surface illumination shall be 200±50Lux under ordinary hite fluorescense lamp of no high frequency lighting.

3)Standard transmitter: burst wave indicated in Fig1.of standard transmitter shall be arranged to 50mVp-p under the measuring circuit specified in Fig2.

NOTE 2. (electro-optical characteristics) shall be satisfied after leaving 1 hours in the normal temperature .

NOTE 3. (electro-optical characteristics) shall be satisfied and 90% or more of the solder area is covered with solder.

Inspection standard

1.Among electrical characteristics , total number shall be inspected on items blow.

1-1 front distance between emitter & detector

1-2 Current consumption

1-3 H level output voltage

1-4 L level output voltage

2.Items except above mentioned are not inspected particularly , but shall fully satisfy

CAUTION (When use and storage of this device)

1.Store and use where there is no force causing transformation or change in quality .

2.Store and use where there is no corrosive gas or sea(salt) breeze .

3.Store and use where there is no extreme humidity .

4.Solder the lead-pin within the condition of ratings. After soldering do not add extra force .

5.Do not wash this device . Wipe the stains of diode side with a soft cloth. You can use the solvent , ethylalcohol or methylalcohol or isupropylene only .

6.To prevent static electricity damage to the Pre-AMP make sure that the human body, the soldering iron is connected to ground before using .

7. Put decoupling device between Vcc and GND for reduce the noise from power supply line .
8. The performance of remote-control system depends on environments condition and ability of periferal parts. Customer should evaluate the performance as total system in those conditions after system up with components such as commander , micon and this receiver module .

Others

1. This device is not design to endure radiative rays and heavily charged particles .
2. In case where any trouble or questions arise, both parties agress to make full discussion covering the said problem .

更改记录表 Engineering Change Notice-Record

版本 Edition	更改日期 Date	主要更改内容 Main Content	拟制 Prepared	确认 Checked
A/0	2020-08-14	新版本发布 New Edition	谢育国	郝三强