

KY6800

30V Dual N-Channel Mosfet

FEATURES

- $R_{DS(ON)} \leq 39m\Omega$ (30m Ω Typ.)
@ $V_{GS}=10V$
- $R_{DS(ON)} \leq 52m\Omega$ (40m Ω Typ.)
@ $V_{GS}=4.5V$

APPLICATIONS

- Load Switch
- Battery Management

SOT-23-6L

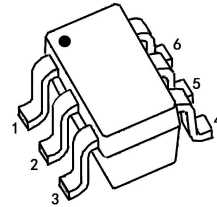

- 1: G1 3: G2 5: S1
2: S2 4: D2 6: D1

MARKING

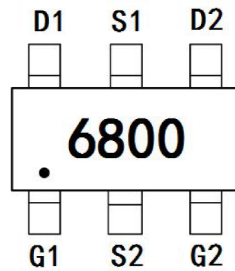

6800:Device Code

N-CHANNEL MOSFET

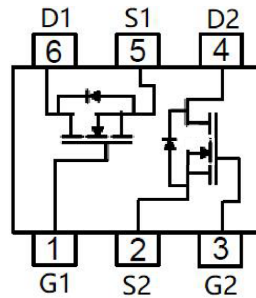

MAXIMUM RATINGS (Ta=25°C unless otherwise noted)

Symbol	Parameter	Max.	Units
V_{DSS}	Drain-Source Voltage	30	V
V_{GSS}	Gate-Source Voltage	± 20	V
I_D	Continuous Drain Current	3.6	A
I_{DM}	Pulsed Drain Current ^{note1}	15	A
P_{tot}	Total Power Dissipation	0.83	W
$R_{\theta JA}$	Thermal Resistance, Junction to Ambient	150	$^{\circ}C/W$
T_J	Junction Temperature	150	$^{\circ}C$
T_{STG}	Storage Temperature Range	-55 to +150	$^{\circ}C$

MOSFET ELECTRICAL CHARACTERISTICS $T_a=25^\circ\text{C}$ unless otherwise specified

Symbol	Parameter	Test Condition	Min.	Typ.	Max.	Units
Off Characteristic						
$V_{(BR)DSS}$	Drain-Source Breakdown Voltage	$V_{GS} = 0V, I_D = 250\mu A$	30	-	-	V
I_{DSS}	Zero Gate Voltage Drain Current	$V_{DS} = 30V, V_{GS} = 0V$	-	-	1	μA
I_{GSS}	Gate to Body Leakage Current	$V_{GS} = \pm 20V, V_{DS} = 0V$	-	-	± 100	nA
On Characteristics						
$V_{GS(th)}$	Gate Threshold Voltage	$V_{DS} = V_{GS}, I_D = 250\mu A$	1.0	1.5	2.2	V
$R_{DS(ON)}$	Gate Drain-Source On-State Resistance <small>note2</small>	$V_{GS} = 10V, I_D = 3.6A$	-	30	39	m Ω
		$V_{GS} = 4.5V, I_D = 3A$	-	40	52	
Dynamic Characteristics <small>note3</small>						
C_{iss}	Input Capacitance	$V_{DS} = 15V, V_{GS} = 0V,$ $f = 1.0MHz$	-	230	-	pF
C_{oss}	Output Capacitance		-	40	-	pF
C_{rss}	Reverse Transfer Capacitance		-	17	-	pF
Q_g	Total Gate Charge	$V_{DS} = 15V, I_D = 3.6A,$ $V_{GS} = 10V$	-	5.0	-	nC
Q_{gs}	Gate-Source Charge		-	1.0	-	nC
Q_{gd}	Gate-Drain("Miller") Charge		-	1.3	-	nC
Switching Characteristics <small>note3</small>						
$t_{d(on)}$	Turn-On Delay Time	$V_{GS} = 4.5V,$ $V_{DS} = 10V, R_G = 6\Omega,$ $I_D = 3.6A$	-	10	-	ns
t_r	Turn-On Rise Time		-	50	-	ns
$t_{d(off)}$	Turn-Off Delay Time		-	10	-	ns
t_f	Turn-Off Fall Time		-	20	-	ns
Drain-Source Diode Characteristics and Maximum Ratings						
V_{SD}	Drain to Source Diode Forward Voltage	$V_{GS} = 0V, I_{SD} = 3.6A,$ $T_J = 25^\circ C$	-	-	1.2	V
t_{rr}	Reverse Recovery Time	$V_{GS} = 0V, I_S = 3.6A,$ $di/dt = 100A/\mu s$	-	7.5	-	ns
Q_{rr}	Reverse Recovery Charge		-	2.5	-	nC

Notes: 1. Repetitive Rating: Pulse width limited by maximum junction temperature

2. Pulse Test: Pulse width $\leq 300\mu s$, Duty Cycle $\leq 2\%$

3. Guaranteed by design, not subject to production testing

Typical Performance Characteristics

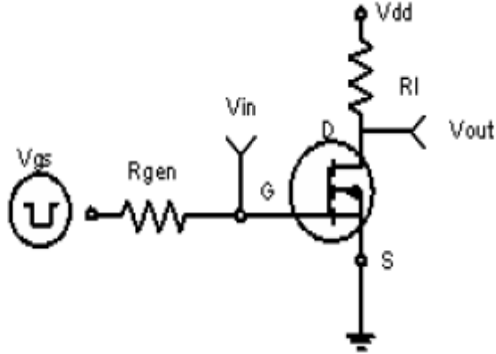

Figure1:Switching Test Circuit

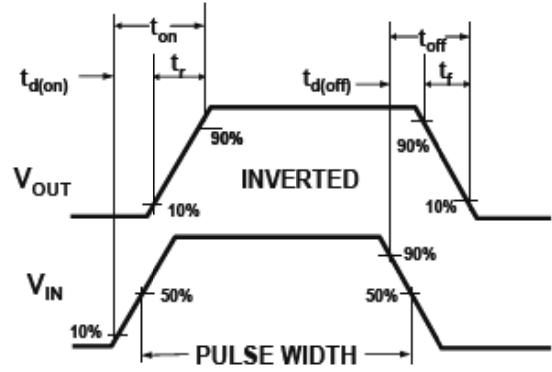
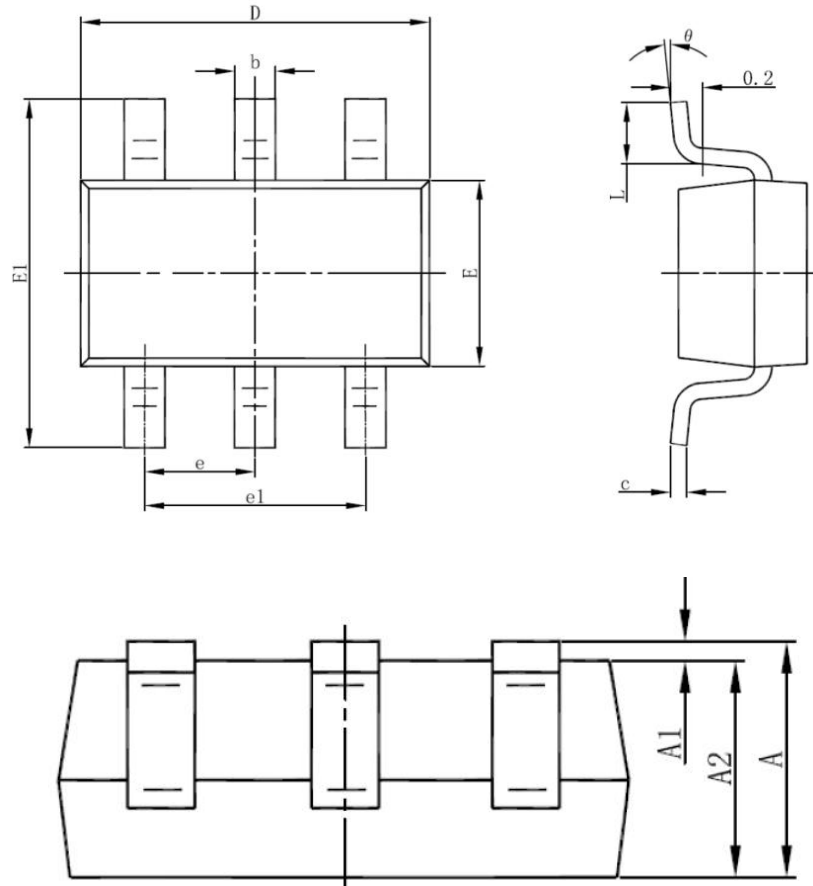

Figure2:Switching Waveforms

SOT-23-6L PACKAGE OUTLINE DRAWING

Symbol	Dimensions In Millimeters		Dimensions In Inches	
	Min	Max	Min	Max
A	1.050	1.250	0.041	0.049
A1	0.000	0.100	0.000	0.004
A2	1.050	1.150	0.041	0.045
b	0.300	0.500	0.012	0.020
c	0.100	0.200	0.004	0.008
D	2.820	3.020	0.111	0.119
E	1.500	1.700	0.059	0.067
E1	2.650	2.950	0.104	0.116
e	0.950 TYP.		0.037 TYP.	
e1	1.800	2.000	0.071	0.079
L	0.300	0.600	0.012	0.024
θ	0°	8°	0°	8°